

# Montageanleitung B17 Hybrid

konfektionierbares Steckergehäuse mit Crimpanschluss, axial,  
4x1,5mm<sup>2</sup> + 4xAWG22, ECP: Powerbuchse / Datenbuchse

## Stückliste

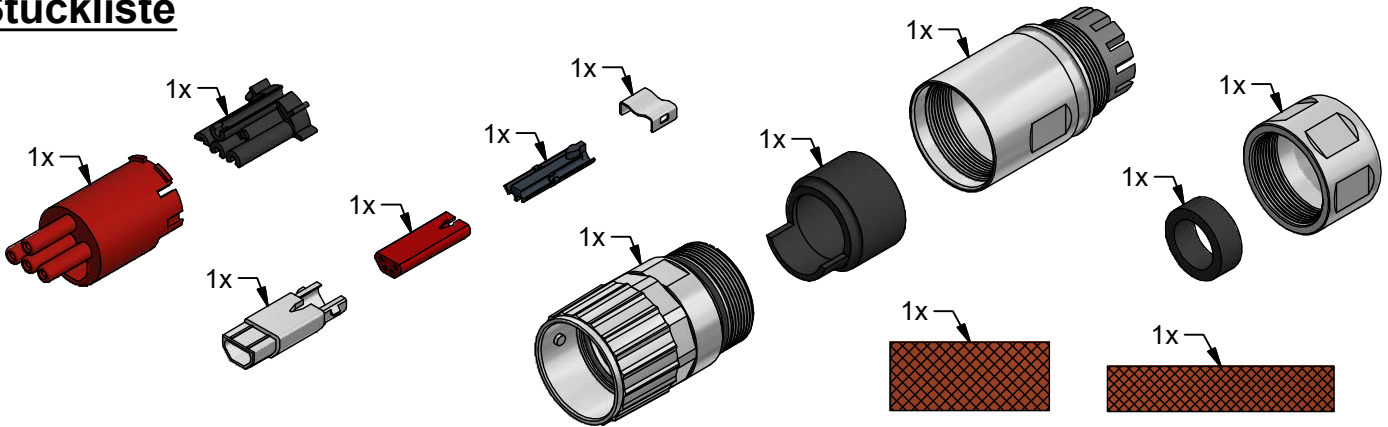

**Laufrichtung beachten!**

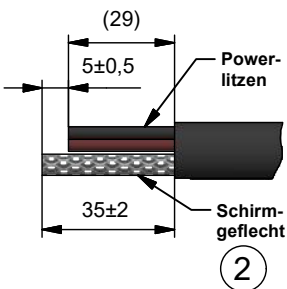
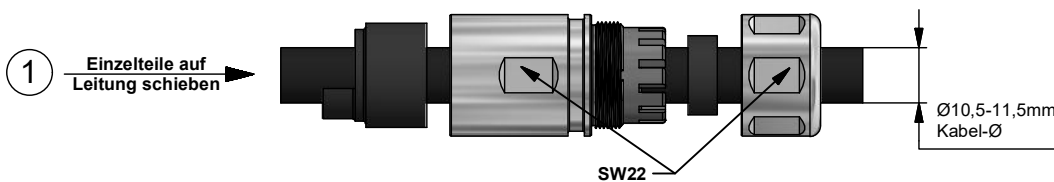

**Füllstoffe bündig mit Kabelmantel wegschneiden!**

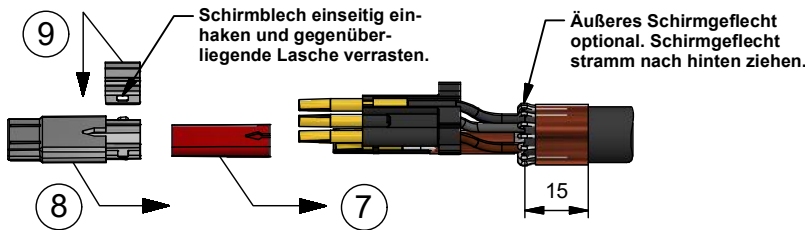
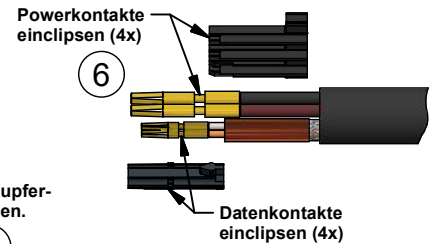
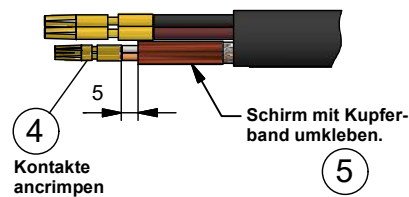
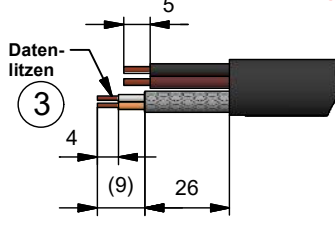

**Achtung: Ansicht von Kabelausgang dargestellt! Auf richtige Farbwahl achten!**

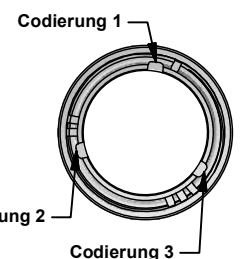
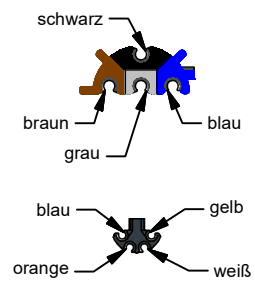

**Nur eine Codierung montierbar!**

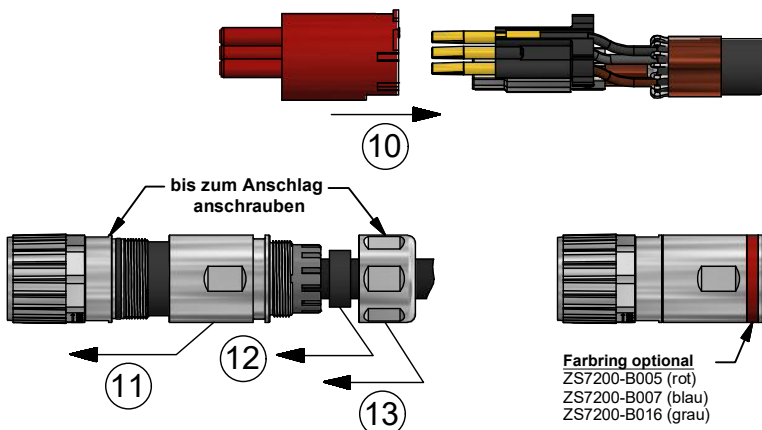

Farbring optional  
ZS7200-B005 (rot)  
ZS7200-B007 (blau)  
ZS7200-B016 (grau)

### Werkzeug / Zubehör

Crimpzange	Crimpeinsatz / Locator
ZB8810-0000	ZB8810-0001

# Assembly instruction B17 hybrid

field attachable plug housing with crimp connection, axial,  
 4x1.5mm<sup>2</sup> + 4xAWG22, ECP: power (female) / data (female)

## parts list

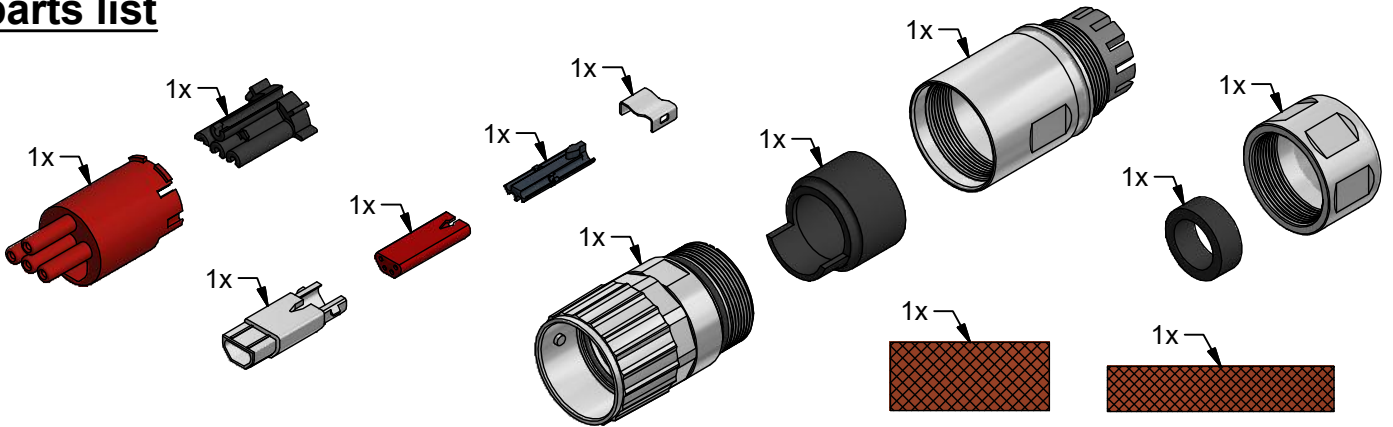

Please consider the cable direction!

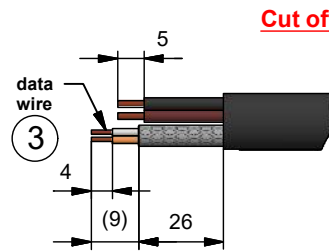
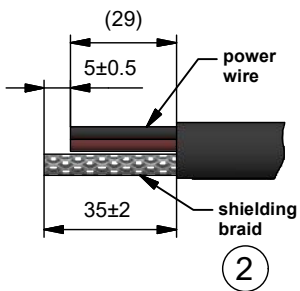
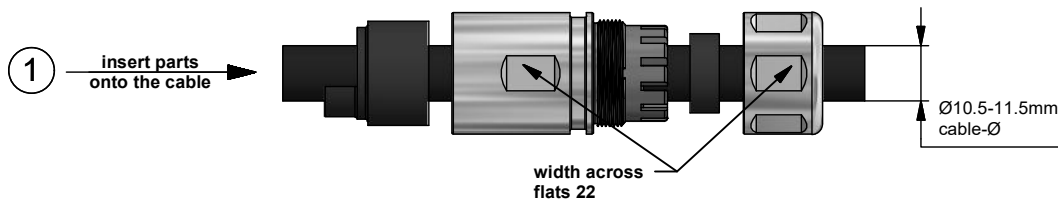

Cut off the fillers!

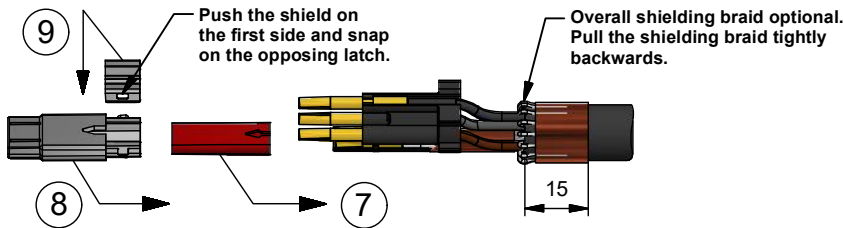
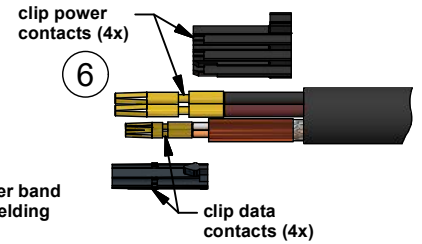
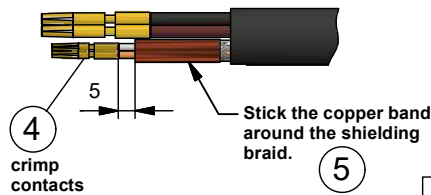

Attention: View from cable outlet!  
 Consider the right choice of colors!

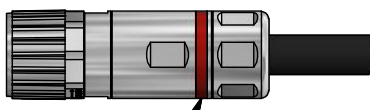
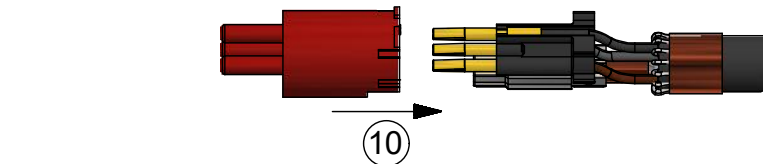
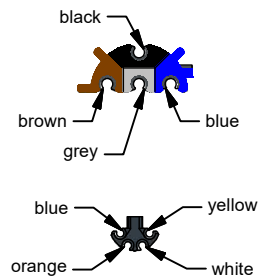

Only one coding mountable!

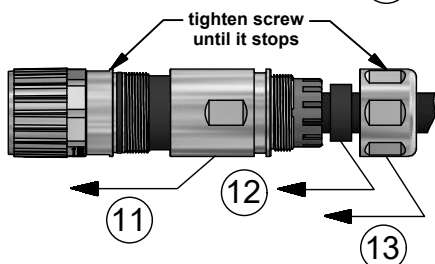

Color ring optional  
 ZS7200-B005 (red)  
 ZS7200-B007 (blue)  
 ZS7200-B016 (grey)

## tools / accessory parts

crimping tool	crimping insert / locator
ZB8810-0000	ZB8810-0001