

Montageanleitung B23 Hybrid

konfektionierbares Steckergehäuse mit Crimpanschluss, axial,
5x4mm² + 4xAWG22, ECP: Powerbuchse / Datenbuchse

Stückliste

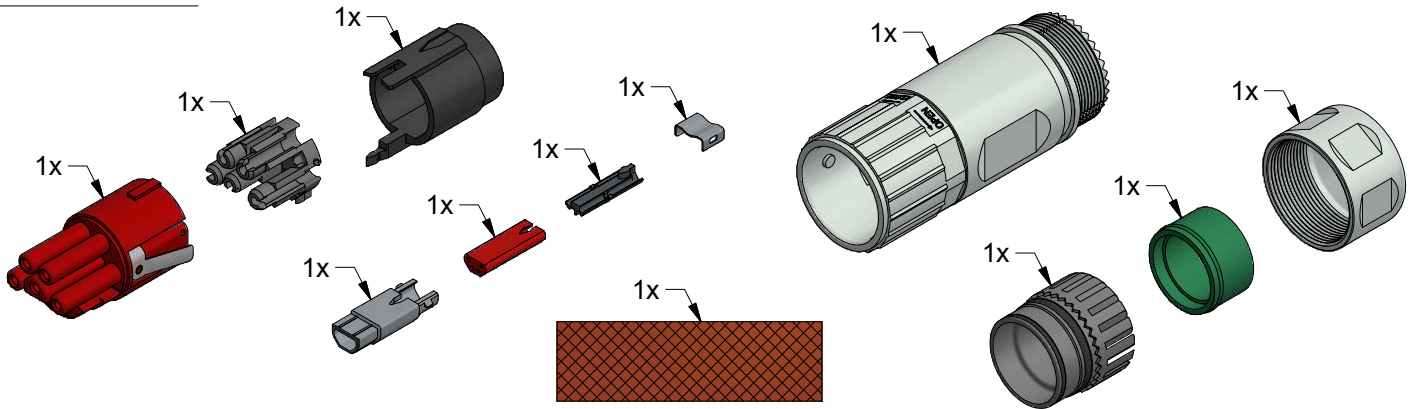

1 Einzelteile auf Leitung schieben

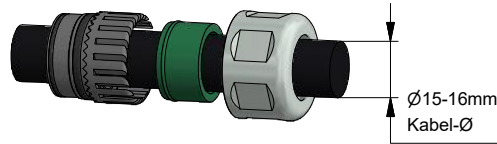

Laufrichtung beachten!

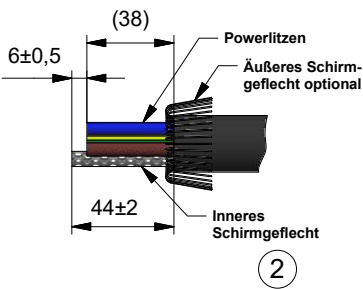

Füllstoffe bündig mit Kabelmantel wegschneiden!

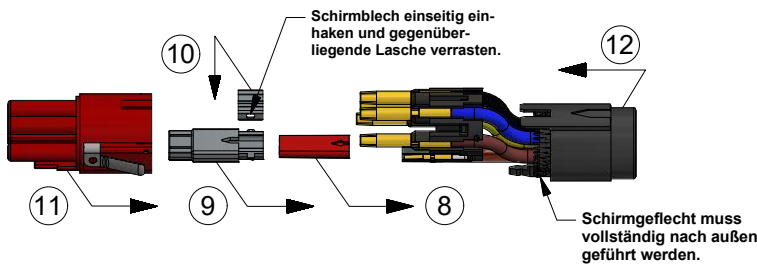
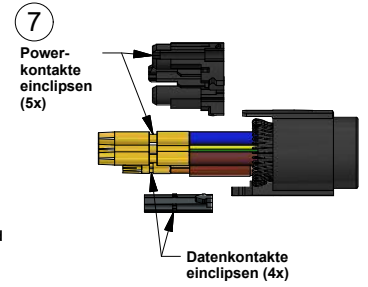
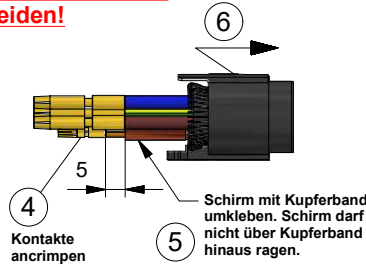
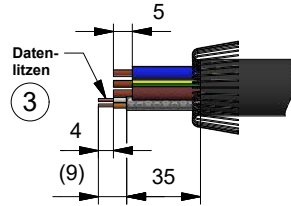

Achtung: Ansicht von hinten dargestellt! Auf richtige Farbwahl achten!

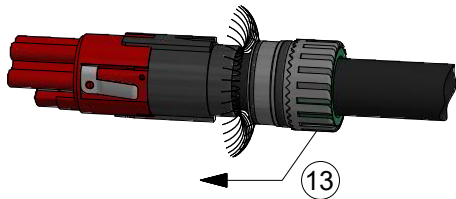
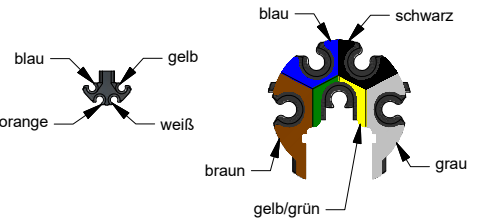

Codiernut für gewünschte Codierung wählen!

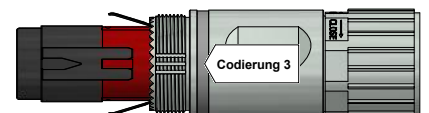
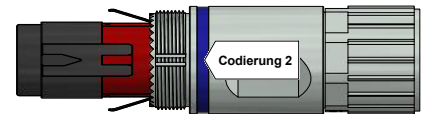
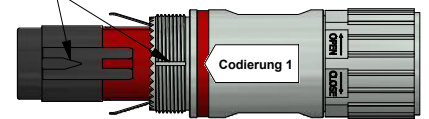

Farbring optional
ZS7300-B005 (rot)
ZS7300-B006 (gelb)
ZS7300-B007 (blau)
ZS7300-B008 (grün)

Schirmgeflecht muss gekürzt werden und darf nicht über O-Ring ragen!

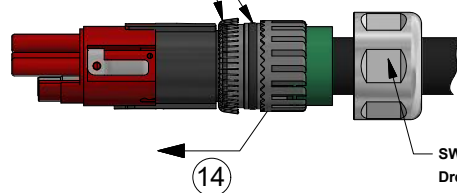
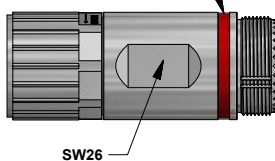

Werkzeug / Zubehör

Crimpzange

ZB8810-0000

Crimpeinsatz / Locator

ZB8810-0002

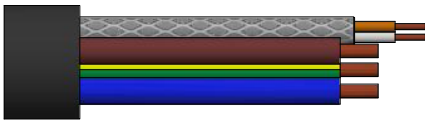

Assembly instruction B23 hybrid

field attachable plug housing with crimp connection, axial,
5x4mm² + 4xAWG22, ECP: power (female) / data (female)

parts list

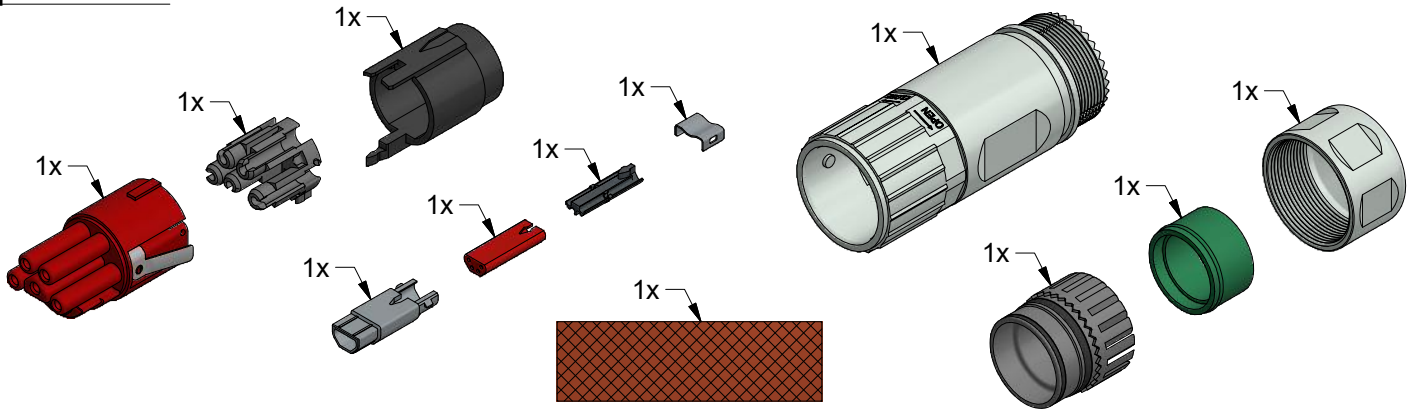

Please consider the cable direction!

1 insert parts onto the cable

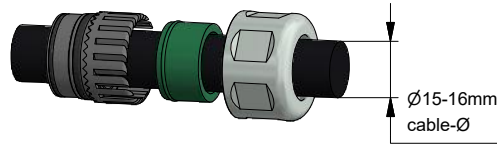

Cut off the fillers!

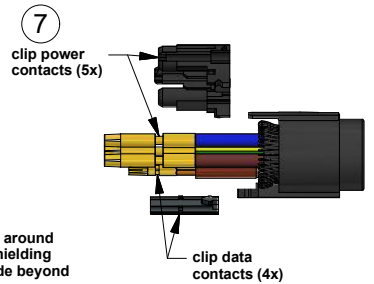
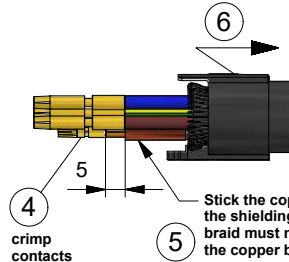
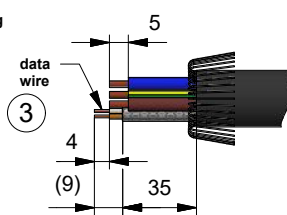
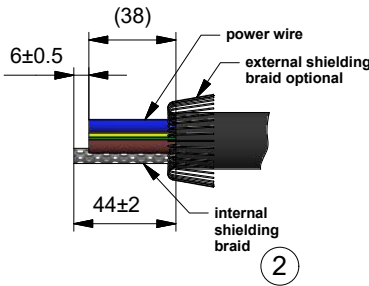

Attention: View from behind! Consider the right choice of colors!

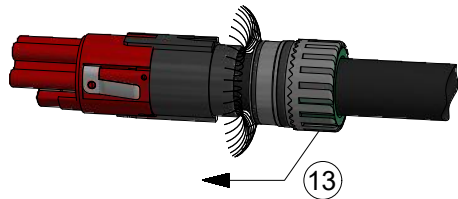
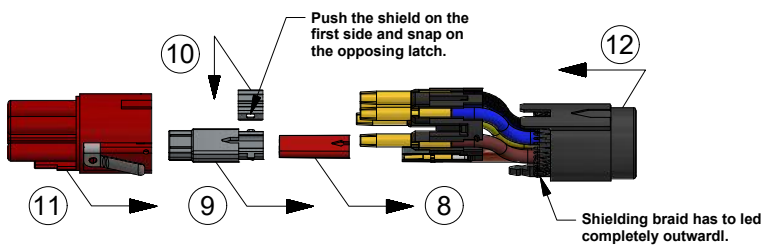
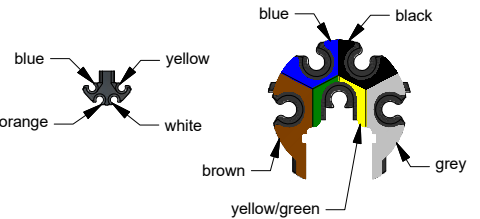

color ring optional
ZS7300-B005 (red)
ZS7300-B006 (yellow)
ZS7300-B007 (blue)
ZS7300-B008 (green)

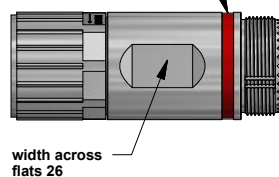

Shielding braid has to be shorten. It isn't allowed to protrude above the o-ring.

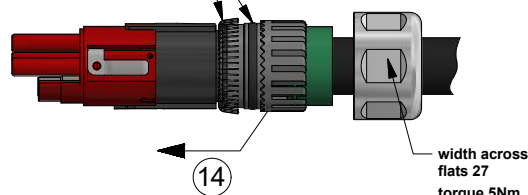

Select the right coding!

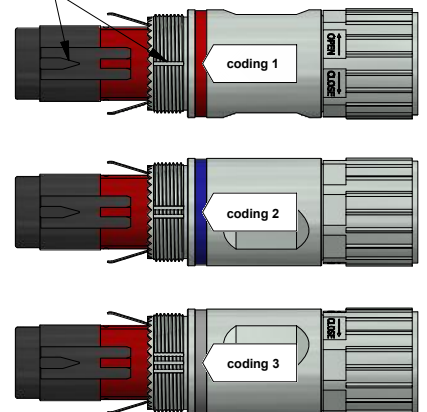

Beckhoff®, TwinCAT®, EtherCAT®, EtherCAT P®, Safety over EtherCAT®, TwinSAFE®, XFC® and XTS® are registered trademarks of and licensed by Beckhoff Automation GmbH. Other designations used in this publication may be trademarks whose use by third parties for their own purposes could violate the rights of the owners.

tools / accessory parts

crimping tool	crimping insert / locator
ZB8810-0000	ZB8810-0002

The information provided in this brochure contains merely general descriptions or characteristics of performance which in case of actual application do not always apply as described or which may change as a result of further development of the products. An obligation to provide the respective characteristics shall only exist if expressly agreed in the terms of contract.