

ZB8501 | Clamp strap for shield connection with knurled screw, width 19 mm, shield diameter 7... 16 mm

Weight	Ca. 17 g
Conformity	RoHS
Suitable shield diameter	7 – 16 mm
Packing unit	10 pieces

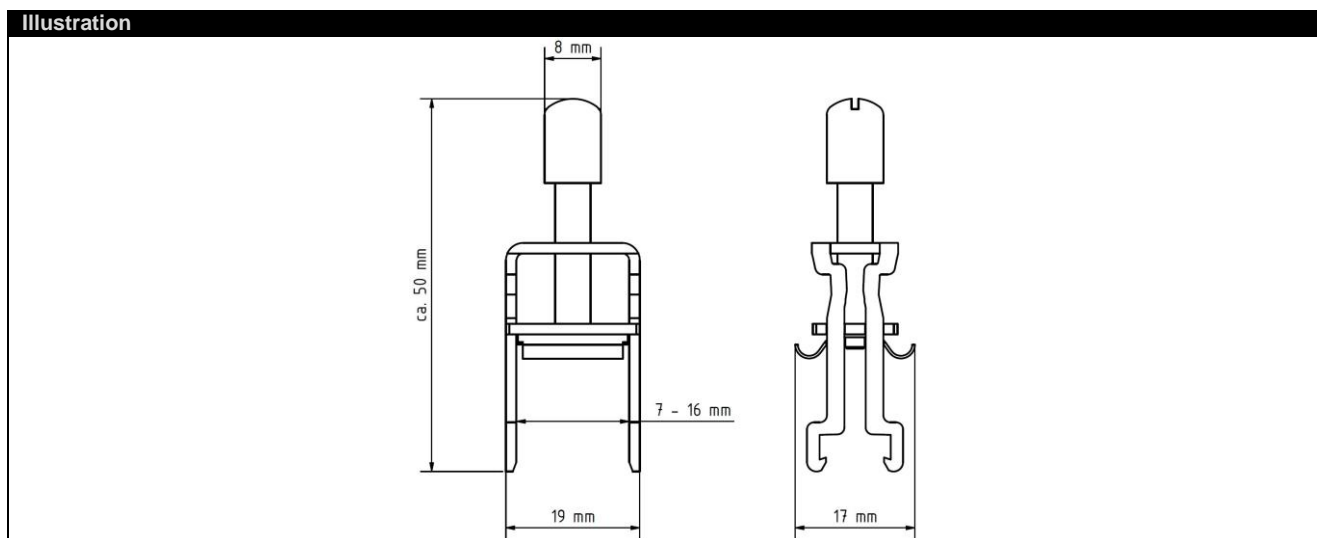

Ordering information	Description
ZB8501	Clamp strap for shield connection with knurled screw, width 19 mm, shield diameter 7...16 mm, packing unit = 10 pieces