

# ZC2000-0000-0021 | Splitter cable, for XPlanar tile APS4322-0000-0000, 2 x 2 layout, PVC, fixed installation



M12, socket, angled, female, 5-pin (4+PE), K-coded – M12, socket, angled, female, 5-pin (4+PE), K-coded – open end, 5-wire – M12, socket, angled, female, 5-pin (4+PE), K-coded – M12, socket, angled, female, 5-pin (4+PE), K-coded



## Plugs

Electrical data	Head A	Head B	Head C	Head E	Head F
Rated voltage	630 V AC/DC (according to IEC 61076-2-111)	630 V AC/DC (according to IEC 61076-2-111)	-	630 V AC/DC (according to IEC 61076-2-111)	630 V AC/DC (according to IEC 61076-2-111)
Rated current	12 A at 40 °C (according to IEC 61076-2-111)	12 A at 40 °C (according to IEC 61076-2-111)	-	12 A at 40 °C (according to IEC 61076-2-111)	12 A at 40 °C (according to IEC 61076-2-111)
Rated impulse voltage	6.0 kV	6.0 kV	-	6.0 kV	6.0 kV
Shielding	no	no	-	no	no
Insulation resistance	≥ 100 GΩ (according to IEC 60512)	≥ 100 GΩ (according to IEC 60512)	-	≥ 100 GΩ (according to IEC 60512)	≥ 100 GΩ (according to IEC 60512)

Mechanical data					
Accessories type	Coupling	Coupling	-	Coupling	Coupling
Installation size	M12	M12	open end	M12	M12
Connector type	socket	socket	-	socket	socket
Configuration	angled	angled	-	angled	angled
Contact type	female	female	-	female	female
Number of positions (face)	5-pin (4+PE)	5-pin (4+PE)	5-wire	5-pin (4+PE)	5-pin (4+PE)
Coding	K-coded	K-coded	-	K-coded	K-coded
Wire termination	screw connection	screw connection	-	screw connection	screw connection
Recommended torque, nut	0.6 Nm	0.6 Nm	-	0.6 Nm	0.6 Nm
Mating cycles	≥ 100	≥ 100	-	≥ 100	≥ 100
Way of locking	screw	screw	-	screw	screw
Body color	black	black	-	black	black
Body material	PA	PA	-	PA	PA
Coupling nut material	PA	PA	-	PA	PA
Contact carrier color	black	black	-	black	black
Contact carrier material	PA, UL 94 V-0	PA, UL 94 V-0	-	PA, UL 94 V-0	PA, UL 94 V-0
Contact plating	Au	Au	-	Au	Au
Contact material	CuZn	CuZn	-	CuZn	CuZn
Max. wire cross-section	AWG16 (1.5 mm <sup>2</sup> ) with wire end ferrule, AWG14 (2.5 mm <sup>2</sup> ) without wire end ferrule	AWG16 (1.5 mm <sup>2</sup> ) with wire end ferrule, AWG14 (2.5 mm <sup>2</sup> ) without wire end ferrule	-	AWG16 (1.5 mm <sup>2</sup> ) with wire end ferrule, AWG14 (2.5 mm <sup>2</sup> ) without wire end ferrule	AWG16 (1.5 mm <sup>2</sup> ) with wire end ferrule, AWG14 (2.5 mm <sup>2</sup> ) without wire end ferrule
Max. cable outer diameter	8.0...13.0 mm	8.0...13.0 mm	-	8.0...13.0 mm	8.0...13.0 mm
Environmental data					
Special features	It is possible to turn and fix the contact carrier in 5 different 72° positions	It is possible to turn and fix the contact carrier in 5 different 72° positions	-	It is possible to turn and fix the contact carrier in 5 different 72° positions	It is possible to turn and fix the contact carrier in 5 different 72° positions
Ambient temperature (operation)	-40...+85 °C, -40...+185 °F	-40...+85 °C, -40...+185 °F	-	-40...+85 °C, -40...+185 °F	-40...+85 °C, -40...+185 °F
Protection rating	IP67 in screwed condition (according to IEC 60529)	IP67 in screwed condition (according to IEC 60529)	-	IP67 in screwed condition (according to IEC 60529)	IP67 in screwed condition (according to IEC 60529)
Pollution level	3	3	-	3	3

Application Note	Robust and high power transmission up to 12 A and 630 V for AC and DC applications	Robust and high power transmission up to 12 A and 630 V for AC and DC applications	Robust and high power transmission up to 12 A and 630 V for AC and DC applications	Robust and high power transmission up to 12 A and 630 V for AC and DC applications
------------------	--	--	--	--

## Cable

Electrical data	
Rated voltage	300 V (according to UL 758/1581)
Wire resistance (power)	1.50 mm <sup>2</sup> : ≤ 13.3 Ω/km, 0.75 mm <sup>2</sup> : ≤ 26.0 Ω/km
Test voltage	4000 V
Mechanical data	
Conductor construction (power)	1.50 mm <sup>2</sup> : 84 x 0.15 mm, 0.75 mm <sup>2</sup> : 42 x 0.15 mm
Cross-section	2 x 0.75 mm <sup>2</sup> (AWG18) + 3 x 1.5 mm <sup>2</sup> (AWG16)
Min. bending radius, moved	12 x outer cable diameter
Min. bending radius, fixed installation	5 x outer cable diameter
Outer cable diameter	8.5 mm ± 0.2 mm (0.3346" ± 0.0079")
Shielding	no
Use	fixed installation
UL-Style	1731
Jacket color	black
Material jacket	PVC (polyvinyl chloride)
Wire color code	1.50 mm <sup>2</sup> : brown, blue, green/yellow 0.75 mm <sup>2</sup> : white, red
Wire insulation material	PVC (polyvinyl chloride)
Environmental data	
Operation temperature range, moved	-5...+105 °C, 23...+221 °F
Operation temperature range, fixed installation	-30...+105 °C, -22...+221 °F
RoHS compliant	yes
Application Note	This cable is used for the various XPlanar splitter cables to supply power to the XPlanar tiles APS4322-0000-0000 in the 2 x 2, 2 x 3 or 1 x 6 layout.

Contact assembly	
------------------	--

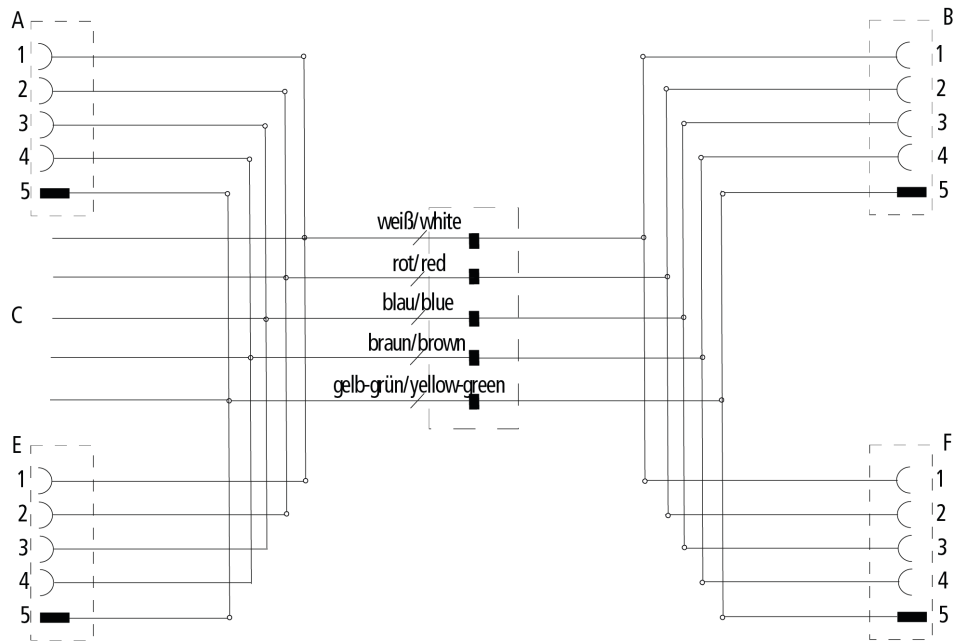

Dimensions

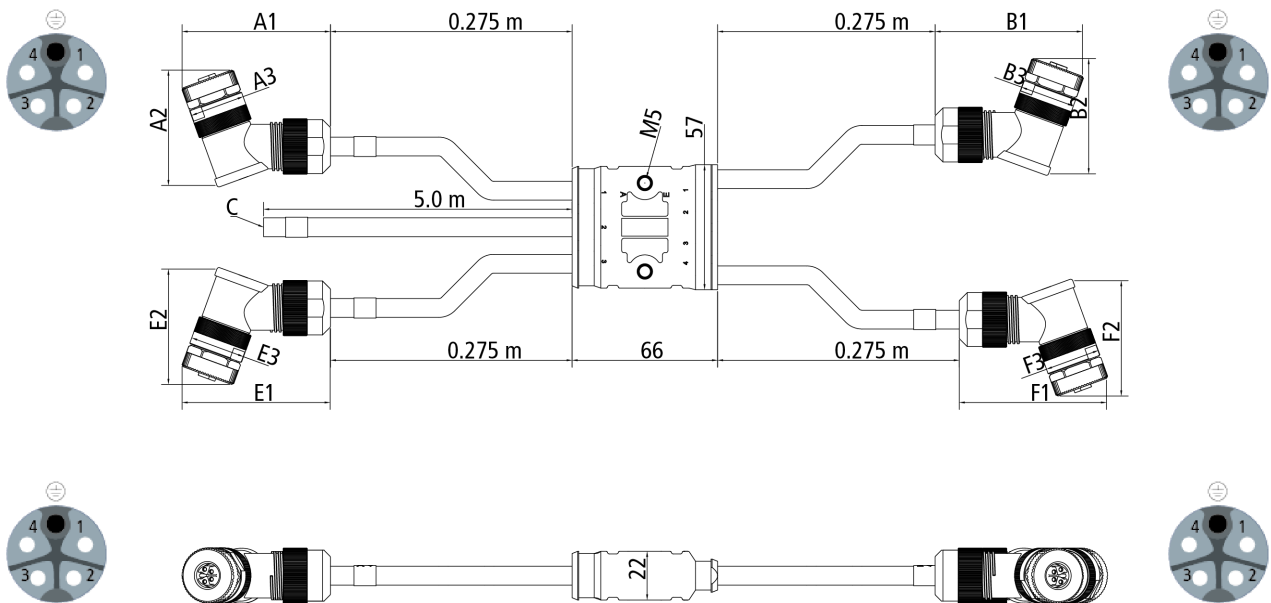

A1	67.0 mm
A2	49.0 mm
A3	25.0 mm
B1	67.0 mm
B2	49.0 mm
B3	25.0 mm
E1	67.0 mm
E2	49.0 mm
E3	25.0 mm

---

F1	67.0 mm
F2	49.0 mm
F3	25.0 mm

---

## Notes

- The following length tolerances apply: 2-3 %
- Illustrations similar

Ordering information	Length
ZC2000-0000-0021	4 x 0.275 m

---



Beckhoff®, TwinCAT®, TwinCAT/BSD®, TC/BSD®, EtherCAT®, EtherCAT G®, EtherCAT G10®, EtherCAT P®, Safety over EtherCAT®, TwinSAFE®, XFC®, XTS® and XPlanar® are registered trademarks of and licensed by Beckhoff Automation GmbH. Other designations used in this publication may be trademarks whose use by third parties for their own purposes could violate the rights of the owners.

© Beckhoff Automation GmbH & Co. KG 08/2022

The information provided in this brochure contains merely general descriptions or characteristics of performance which in case of actual application do not always apply as described or which may change as a result of further development of the products. An obligation to provide the respective characteristics shall only exist if expressly agreed in the terms of contract.