

Documentation | EN

# KL31x2/KS31x2

Two Channel Accurate Analog Terminals

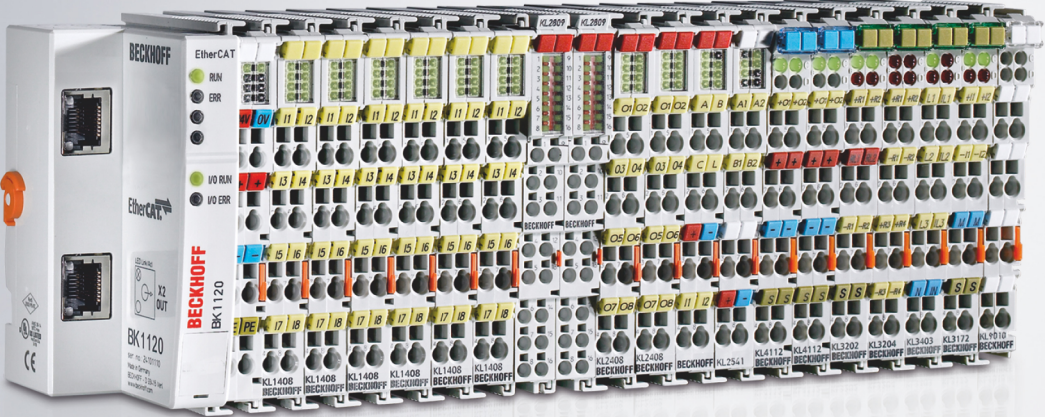



# Table of contents

<b>1 Foreword</b> .....	<b>5</b>
1.1 Notes on the documentation .....	5
1.2 Safety instructions .....	6
1.3 Documentation issue status .....	7
<b>2 Product overview</b> .....	<b>9</b>
2.1 KL3132, KL3162, KL3172, KL3182.....	9
2.1.1 Introduction .....	9
2.1.2 Technical data.....	10
2.2 KL3142, KL3152 .....	11
2.2.1 Introduction .....	11
2.2.2 Technical data.....	12
2.3 LEDs .....	13
2.4 Basic function principles.....	14
2.5 Continuative documentation for I/O components with analog in and outputs .....	17
<b>3 Mounting and wiring</b> .....	<b>18</b>
3.1 Instructions for ESD protection .....	18
3.2 Installation on mounting rails.....	19
3.3 Disposal .....	21
3.4 Connection .....	22
3.4.1 Connection system.....	22
3.4.2 Wiring.....	24
3.4.3 Shielding .....	25
3.4.4 Contact assignment .....	26
3.5 ATEX - Special conditions (standard temperature range).....	28
3.6 Continuative documentation for ATEX and IECEx.....	29
3.7 Application example for KL3172-0000 .....	30
<b>4 Configuration Software KS2000</b> .....	<b>31</b>
4.1 KS2000 - Introduction .....	31
4.2 Parameterization with KS2000 .....	33
4.3 Register .....	35
4.4 Settings .....	36
4.5 Sample program for register communication via EtherCAT on KL3314 exemplary.....	38
<b>5 Data structures</b> .....	<b>41</b>
5.1 Process image .....	41
5.2 Mapping .....	42
5.3 Control and status byte .....	44
5.4 Register overview.....	47
5.5 Register description .....	48
5.6 Examples of Register Communication .....	54
5.6.1 Example 1: Reading the firmware version from register 9 .....	54
5.6.2 Example 2: Writing to an user register .....	54
<b>6 Appendix</b> .....	<b>58</b>
6.1 Beckhoff Identification Code (BIC) .....	58

---

6.2 Support and Service..... 60

# 1 Foreword

## 1.1 Notes on the documentation

### Intended audience

This description is only intended for the use of trained specialists in control and automation engineering who are familiar with the applicable national standards.

It is essential that the documentation and the following notes and explanations are followed when installing and commissioning these components.

It is the duty of the technical personnel to use the documentation published at the respective time of each installation and commissioning.

The responsible staff must ensure that the application or use of the products described satisfy all the requirements for safety, including all the relevant laws, regulations, guidelines and standards.

### Disclaimer

The documentation has been prepared with care. The products described are, however, constantly under development.

We reserve the right to revise and change the documentation at any time and without prior announcement.

No claims for the modification of products that have already been supplied may be made on the basis of the data, diagrams and descriptions in this documentation.

### Trademarks

Beckhoff®, TwinCAT®, TwinCAT/BSD®, TC/BSD®, EtherCAT®, EtherCAT G®, EtherCAT G10®, EtherCAT P®, Safety over EtherCAT®, TwinSAFE®, XFC®, XTS® and XPlanar® are registered trademarks of and licensed by Beckhoff Automation GmbH. Other designations used in this publication may be trademarks whose use by third parties for their own purposes could violate the rights of the owners.

### Patent Pending

The EtherCAT Technology is covered, including but not limited to the following patent applications and patents: EP1590927, EP1789857, EP1456722, EP2137893, DE102015105702 with corresponding applications or registrations in various other countries.

The logo for EtherCAT, featuring the word "EtherCAT" in a bold, black, sans-serif font. A red arrow points from the top of the "A" towards the right, ending above the "T". A registered trademark symbol (®) is located to the right of the "T".

EtherCAT® is registered trademark and patented technology, licensed by Beckhoff Automation GmbH, Germany.

### Copyright

© Beckhoff Automation GmbH & Co. KG, Germany.

The reproduction, distribution and utilization of this document as well as the communication of its contents to others without express authorization are prohibited.

Offenders will be held liable for the payment of damages. All rights reserved in the event of the grant of a patent, utility model or design.

## 1.2 Safety instructions

### Safety regulations

Please note the following safety instructions and explanations!  
Product-specific safety instructions can be found on following pages or in the areas mounting, wiring, commissioning etc.

### Exclusion of liability

All the components are supplied in particular hardware and software configurations appropriate for the application. Modifications to hardware or software configurations other than those described in the documentation are not permitted, and nullify the liability of Beckhoff Automation GmbH & Co. KG.

### Personnel qualification

This description is only intended for trained specialists in control, automation and drive engineering who are familiar with the applicable national standards.

### Description of instructions

In this documentation the following instructions are used.  
These instructions must be read carefully and followed without fail!

#### **DANGER**

##### **Serious risk of injury!**

Failure to follow this safety instruction directly endangers the life and health of persons.

#### **WARNING**

##### **Risk of injury!**

Failure to follow this safety instruction endangers the life and health of persons.

#### **CAUTION**

##### **Personal injuries!**

Failure to follow this safety instruction can lead to injuries to persons.

#### **NOTE**

##### **Damage to environment/equipment or data loss**

Failure to follow this instruction can lead to environmental damage, equipment damage or data loss.



##### **Tip or pointer**

This symbol indicates information that contributes to better understanding.

### 1.3 Documentation issue status

Version	Comment
2.6.0	<ul style="list-style-type: none"> <li>Chapter <i>Basic function principles</i> updated</li> <li>Reference to the further documentation <i>I/O Analog Manual</i> added</li> <li>Revision status updated</li> </ul>
2.5.0	<ul style="list-style-type: none"> <li>Chapter <i>Technical data</i> updated</li> <li>Document structure updated</li> <li>Chapter <i>Instructions for ESD protection</i> added</li> <li>Chapter <i>Disposal</i> added</li> <li>New title page</li> </ul>
2.4.0	<ul style="list-style-type: none"> <li>Note on differential measurement added</li> </ul>
2.3.0	<ul style="list-style-type: none"> <li>Example program added to chapter <i>KS2000 Configuration software</i></li> </ul>
2.2.0	<ul style="list-style-type: none"> <li>Chapter <i>Technical data</i> updated (voltage measurement terminals only)</li> </ul>
2.1.0	<ul style="list-style-type: none"> <li>Chapter <i>Basic function principles</i> updated</li> </ul>
2.0.0	<ul style="list-style-type: none"> <li>Migration</li> </ul>
1.6.0	<ul style="list-style-type: none"> <li>Title page and introduction corrected</li> <li>Preface updated</li> <li>Technical data updated</li> </ul>
1.5.0	<ul style="list-style-type: none"> <li>Register description updated (R32)</li> <li>Technical data updated</li> <li>KL3172-0500 and KL3172-1000 added</li> <li>ATEX notes added</li> </ul>
1.4	<ul style="list-style-type: none"> <li>Control and status byte updated</li> <li>Mounting description expanded</li> </ul>
1.3	<ul style="list-style-type: none"> <li>LED descriptions updated (prisms, new RUN LEDs)</li> <li>Connection description updated (power contacts, new pin assignment for terminal points)</li> <li>Channel switch-off added</li> <li>Technical data of the KL3142 and KL3152 updated</li> </ul>
1.2.1	<ul style="list-style-type: none"> <li>Pin assignment corrected</li> </ul>
1.2	<ul style="list-style-type: none"> <li>Register description extended (command 7000)</li> </ul>
1.1	<ul style="list-style-type: none"> <li>Technical data updated</li> <li>Description of terminal points 3 and 7 adapted to final pin assignment</li> <li>KL3132, KL3142, KL3152, KL3162 and KL3182 added</li> </ul>
1.0	First version (KL3172 only)

## Firmware and hardware versions

Documentation, Version	KL3132, KS3132		KL3142, KS3142		KL3152, KS3152		KL3162, KS3162		KL3172, KS3172		KL3172-0500, KS3172-0500, KL3172-1000, KS3172-1000		KL3182, KS3182	
	Firmw	Hardw	Firmw	Hardw	Firmw	Hardw	Firmw	Hardw	Firmw	Hardw	Firmw	Hardw	Firmw	Hardw
2.6.0	2D	05	3A	06	3A	07	2E	06	2D	04	2D	04	2D	05
2.5.0	2D	05	3A	06	3A	07	2D	06	2D	04	2D	04	2D	05
2.4.0	2D	05	2E	05	2D	05	2D	06	2D	04	2D	04	2D	04
2.3.0	2D	05	2E	05	2D	05	2D	05	2D	04	2D	04	2D	04
2.2.0	2D	04	2E	04	2D	04	2D	04	2D	03	2D	03	2D	03
2.1.0	2D	04	2E	04	2D	04	2D	04	2D	03	2D	03	2D	03
2.0.0	2D	04	2E	04	2D	04	2D	04	2D	03	2D	03	2D	03
1.6.0	2D	03	2E	03	2D	03	2D	03	2D	02	2D	02	2D	02
1.5.0	2D	03	2E	03	2D	03	2D	03	2D	02	2D	02	2D	02
1.4	2A	01	2B	01	2A	01	2A	01	2A	01	-	-	2A	01
1.3	2A	01	2A	01	2A	01	2A	01	2A	01	-	-	2A	01
1.2.1	1A	00	1A	00	1A	00	1A	00	1B	00	-	-	1A	00
1.2	1A	00	1A	00	1A	00	1A	00	1B	00	-	-	1A	00
1.1	1A	00	1A	00	1A	00	1A	00	1B	00	-	-	1A	00
1.0	-	-	-	-	-	-	-	-	B1	00	-	-	-	-

The firmware and hardware versions (delivery state) can be taken from the serial number printed on the side of the terminal.

### Syntax of the serial number

Structure of the serial number: WW YY FF HH

WW - week of production (calendar week)

YY - year of production

FF - firmware version

HH - hardware version

Example with serial number 35 04 1B 01:

35 - week of production 35

04 - year of production 2004

1B - firmware version 1B

01 - hardware version 1



## 2 Product overview

### 2.1 KL3132, KL3162, KL3172, KL3182

#### 2.1.1 Introduction

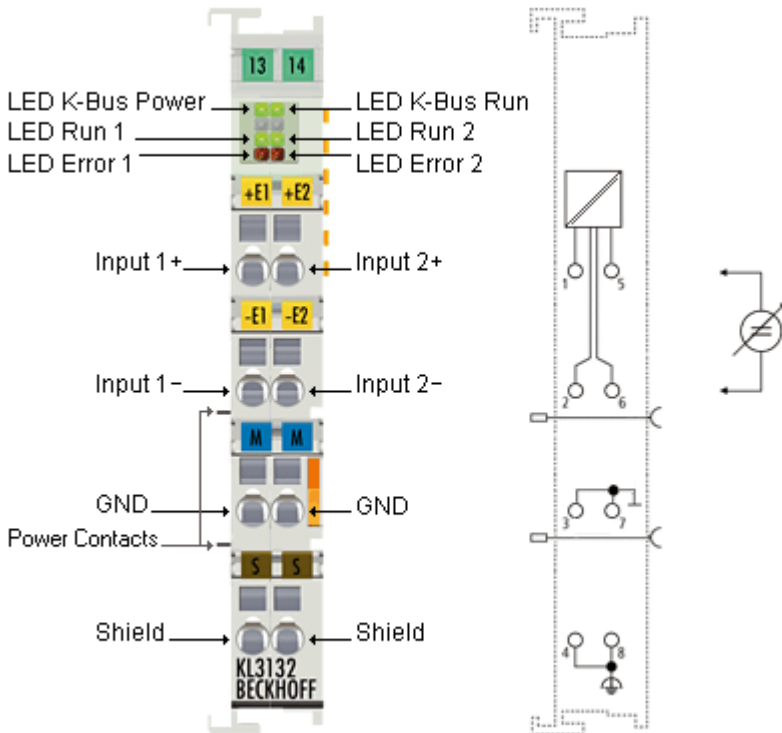

Fig. 1: KL3132

#### Two-channel analog terminals with voltage inputs (0.05% accuracy)

The analog input terminals KL3132, KL3162, KL3172 and KL3182 process signals in the range -10 V to +10 V. The voltage is digitized to a resolution of 16 bits, and is transmitted, electrically isolated, to the higher-level automation device. The input channels of one Bus Terminal have differential inputs and possess a common, internal ground potential. With their small measuring error of  $\pm 0.05\%$  of the full scale value, these terminals are optimized for high-precision control processes, such as dosing, filling, or quality assurance. The Bus Terminals combine 2 channels in a single housing. Status and error LEDs indicate the terminal state.

#### Overview

KL3132-0000: -10 ... +10 V  
 KL3162-0000: 0 ... +10 V

KL3172-0000: 0.0 ... +2.0 V  
 KL3172-0500: 0.0 ... +0.5 V  
 KL3172-1000: 0.0 ... +1.0 V

KL3182-0000: -2.0 ... +2.0 V

## 2.1.2 Technical data

Technical data	KL3132-0000, KS3132-0000	KL3162-0000, KS3162-0000	KL3172-0000, KS3172-0000	KL3172-0500, KS3172-0500	KL3172-1000, KS3172-1000	KL3182-0000, KS3182-0000
Number of inputs	2					
Input signal	-10 V ... +10 V	0 ... 10 V	0 ... 2 V	0 ... 500 mV	0 ... 1 V	-2 V ... +2 V
Input resistance	> 70 kΩ					
Common-mode voltage $U_{CM}$	±10 V					
Resolution	16 bit					
Conversion time	140 ms, configurable					
Measuring error (full measuring range)	±0.05% of the full scale value, self-calibration					
Bit width in the K-Bus I/O	2 x 16 bit user data (optionally 2 x 8 bit control/status)					
Bit width in the input process image	2 data words, 2 status byte					
Bit width in the output process image	2 data words, 2 control byte					
Power supply for the electronics	via the K-bus					
Current consumption from K-bus	typically 85 mA					
Electrical isolation	500 V (differential input / K-bus)					
Connection	spring-loaded system					
Pluggable wiring	for all KSxxxx terminals					
Weight	approx. 70 g					
Dimensions (W x H x D)	approx. 15 mm x 100 mm x 70 mm (width aligned: 12 mm)					
Mounting <a href="#">[► 19]</a>	on 35 mm mounting rail conforms to EN 60715					
Permissible ambient temperature range during operation	0°C ... + 55°C					
Permissible ambient temperature range during storage	-25°C ... + 85°C					
Permissible relative air humidity	95%, no condensation					
Vibration / shock resistance	conforms to EN 60068-2-6 / EN 60068-2-27					
EMC immunity / emission	conforms to EN 61000-6-2 / EN 61000-6-4					
Protection class	IP20					
Installation position	variable					
Approval/Markings*	CE, UKCA, cULus, EAC, ATEX <a href="#">[► 28]</a>					

\*) Real applicable approvals/markings see type plate on the side (product marking).

### Ex marking

Standard	Marking
ATEX	II 3 G Ex nA IIC T4 Gc

## 2.2 KL3142, KL3152

### 2.2.1 Introduction

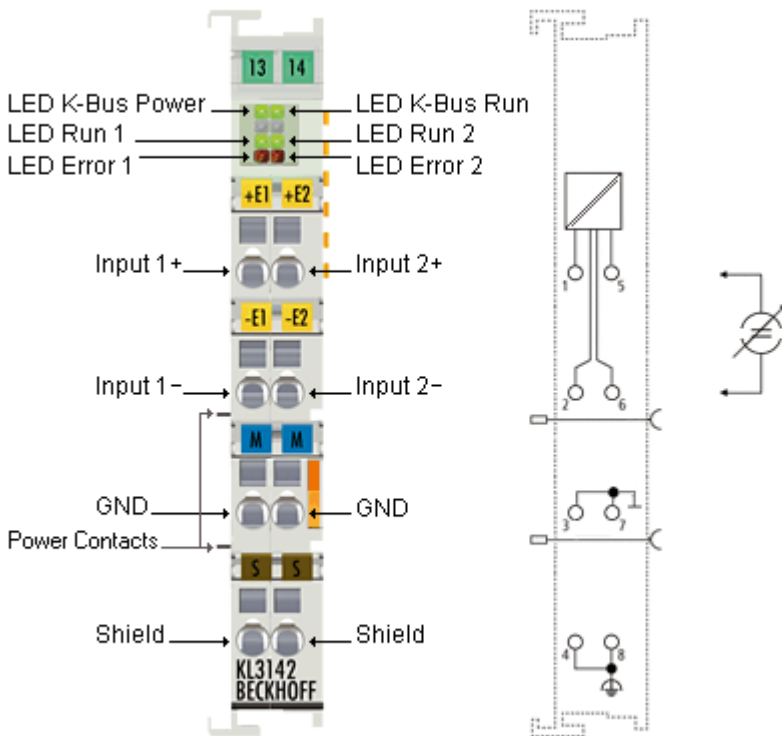

Fig. 2: KL3142

#### Two-channel analog terminals with current inputs (0.05% accuracy)

The KL3142 and KL3152 analog input terminals handle signals in the range between 0 and 20 mA, and between 4 and 20 mA respectively. The current is digitized to a resolution of 16 bits (default: 15 bits), and is transmitted, in an electrically isolated form, to the higher-level automation device. The input channels of the Bus Terminals have differential inputs and possess a common, internal ground potential. With their small measuring error of  $\pm 0.05\%$  of the full scale value, these terminals are optimized for high-precision control processes, such as dosing, filling, or quality assurance. The Bus Terminals combine 2 channels in a single housing. An open lead or overload condition are detected, and the terminal status is relayed to the controller via the K-bus. Status and error LEDs indicate the terminal state.

#### Overview

KL3142-0000: 0 ... 20 mA

KL3152-0000: 4 ... 20 mA

## 2.2.2 Technical data

Technical data	KL3142-0000, KS3142-0000	KL3152-0000, KS3152-0000
Number of inputs	2	
Signal current	0 ... 20 mA	4 ... 20 mA
Internal resistance	100 $\Omega$ measuring resistance	
Common-mode voltage $U_{CM}$	$\pm 10$ V	
Resolution	16 bit	
Conversion time	140 ms, configurable	
Measuring error (full measuring range)	$\pm 0.05\%$ of the full scale value, self-calibration	
Bit width in the K-Bus I/O	2 x 16 bit user data (optionally 2 x 8 bit control/status)	
Bit width in the input process image	2 data words, 2 status byte	
Bit width in the output process image	2 data words, 2 control byte	
Power supply for the electronics	via the K-bus	
Current consumption from K-bus	typically 85 mA	
Surge voltage resistance	35 $V_{DC}$	
Electrical isolation	500 V (differential input / K-bus)	
Connection	spring-loaded system	
Pluggable wiring	for all KSxxxx terminals	
Weight	approx. 70 g	
Dimensions (W x H x D)	approx. 15 mm x 100 mm x 70 mm (width aligned: 12 mm)	
Mounting [ <a href="#">▶ 19</a> ]	on 35 mm mounting rail conforms to EN 60715	
Permissible ambient temperature range during operation	0°C ... + 55°C	
Permissible ambient temperature range during storage	-25°C ... + 85°C	
Permissible relative air humidity	95%, no condensation	
Vibration / shock resistance	conforms to EN 60068-2-6 / EN 60068-2-27	
EMC immunity / emission	conforms to EN 61000-6-2 / EN 61000-6-4	
Protection class	IP20	
Installation position	variable	
Approval/Markings*	CE, UKCA, cULus, EAC, ATEX [ <a href="#">▶ 28</a> ]	

\*) Real applicable approvals/markings see type plate on the side (product marking).

### Ex marking

Standard	Marking
ATEX	II 3 G Ex nA IIC T4 Gc

## 2.3 LEDs

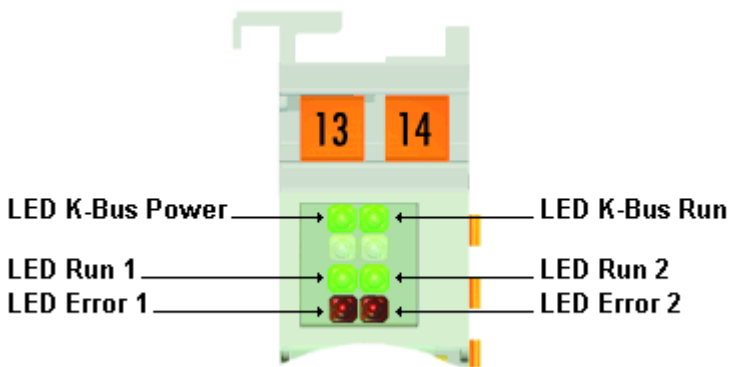

Fig. 3: LEDs

LED	Display	
K-bus power (green)	ON	Power supply (5 V) available on the K-bus
	OFF	No power supply (5 V) available on the K-bus
K-Bus Run (green)	ON	Data transmission on the K-bus is active
	OFF	Data transmission on the K-bus is not active
Run 1 (green)	ON	Channel 1 active: <ul style="list-style-type: none"> <li>process data contain valid analog value</li> </ul>
	OFF	Channel 1 not active: <ul style="list-style-type: none"> <li>Calibration is performed, analog value in the process data not current (frozen or zero)</li> <li>or channel 1 is switched off (if LED error 1 not lit)</li> </ul>
Error 1 (red)	ON	<ul style="list-style-type: none"> <li>Analog value of channel 1 is above the valid measuring range, specified through register <a href="#">R21 [▶ 50]</a> of channel 1. Bit <a href="#">SB1.1 [▶ 44]</a> is set in the status byte of channel 1.</li> <li>Analog value of channel 1 is below the valid measuring range, specified through register <a href="#">R22 [▶ 50]</a> of channel 1. Bit <a href="#">SB1.0 [▶ 44]</a> is set in the status byte of channel 1.</li> <li>Calibration is in progress. The LED goes out when the calibration is complete.</li> </ul>
	OFF	<ul style="list-style-type: none"> <li>Analog value of channel 1 is within the valid measuring range (if LED Run 1 is lit)</li> <li>or channel 1 is switched off (if LED Run 1 is not lit)</li> </ul>
Run 2 (green)	ON	Channel 2 active: <ul style="list-style-type: none"> <li>process data contain valid analog value</li> </ul>
	OFF	Channel 2 not active: <ul style="list-style-type: none"> <li>Calibration is performed, analog value in the process data not current (frozen or zero)</li> <li>or channel 2 is switched off (if LED error 2 not lit)</li> </ul>
Error 2 (red)	ON	<ul style="list-style-type: none"> <li>Analog value of channel 2 is above the valid measuring range, specified through register <a href="#">R21 [▶ 50]</a> of channel 2. Bit <a href="#">SB2.1 [▶ 46]</a> is set in the status byte of channel 2.</li> <li>Analog value of channel 2 is below the valid measuring range, specified through register <a href="#">R22 [▶ 50]</a> of channel 2. Bit <a href="#">SB2.0 [▶ 46]</a> is set in the status byte of channel 2.</li> <li>Calibration is in progress. The LED goes out when the calibration is complete.</li> </ul>
	OFF	<ul style="list-style-type: none"> <li>Analog value of channel 2 is within the valid measuring range (if LED Run 2 is lit)</li> <li>or channel 2 is switched off (if LED Run 2 is not lit)</li> </ul>

### Limiting the measuring range

The terminal indicates any violation of the measuring range to the higher-level controller via the status byte. If the current measured value is:

- greater than specified in register [R21 \[▶ 50\]](#), bit 1 is set in the status byte,
- smaller than specified in register [R22 \[▶ 50\]](#), bit 0 is set in the status byte.

In both cases, the ERROR LED of the respective channel will be on. This display can be disabled through bit [R32.8 \[▶ 50\]](#).

## 2.4 Basic function principles

The high-precision KL3172 analog input terminals can measure two voltages (KL3132, KL3162, KL3172, KL3182) or two currents (KL3142, KL3152) and display them with a resolution of 16 bits (65535 steps). High-precision measurements are ensured through cyclic self-calibration.

By default, the inputs are switched as differential inputs. For terminals KL3132, KL3162, KL3172 and KL3182, terminal point -E1 of the first channel can be switched to internal analog ground with bit [R32.6](#) [[► 50](#)] of the feature register.

### Specification

The specification values are valid after at least 30 minutes warm-up time. The self-calibration largely compensates for internal drifts, but the internal reference (like any electronic component) is slightly temperature dependent and must stabilize.

The channels of the KL31x2 are not electrically isolated. Note CommonMode effects.

### Process data

Analog values are represented as follows:

Input signal						Value	
KL3142-0000	KL3152-0000	KL3162-0000	KL3172-0000	KL3172-0500	KL3172-1000	dec	hex
0 mA	4 mA	0 V	0 V	0 V	0 V	0	0x0000
20 mA	20 mA	10 V	2 V	500 mV	1 V	65535	0xFFFF
Input signal						Value	
KL3132-0000			KL3182-0000			dec	hex
-10 V			-2 V			-32768	0x8000
+10 V			+2 V			+32767	0x7FFF

### Calculation

The terminal continuously records measured values and stores the raw values of its A/D converter in register [R0](#) [[► 48](#)] (RAM). After each acquisition of the analog signal, a correction is calculated using the compensation and, if necessary, calibration values. This is followed by manufacturer and user scaling:

$$Y_A = (X_{ADC} + B_A) \times A_A \quad (1.0) \quad \text{Manufacturer compensation (if calibration inactive)}$$

$$Y_A = ((X_{ADC} + B_K) \times A_A) \times (A_{GK} / A_K) \quad (1.1) \quad \text{Manufacturer compensation / calibration (if calibration activated)}$$

$$Y_H = Y_A \times A_H + B_H \quad (1.2) \quad \text{Manufacturer scaling}$$

$$Y_{off} = Y_H \times A_W + B_W \quad (1.3) \quad \text{User scaling}$$

**Legend**

Name	Name	Unit	Register
X <sub>ADC</sub>	Output value of the A/D converter	[1]	-
Y <sub>off</sub>	Process data for controller	[1]	-
B <sub>A</sub>	Vendor calibration: offset (can be deactivated via bit <a href="#">R32.5</a> [ <a href="#">▶ 50</a> ] of the feature register)	[1]	<a href="#">R17</a> [ <a href="#">▶ 49</a> ]
A <sub>A</sub>	Vendor calibration: gain (always active)	$[1 \times 2^{-16} + 1]$	<a href="#">R18</a> [ <a href="#">▶ 49</a> ]
B <sub>K</sub>	Calibration: offset (can be activated via bit <a href="#">R32.5</a> [ <a href="#">▶ 50</a> ] of the feature register)	[1]	<a href="#">R1</a> [ <a href="#">▶ 48</a> ]
A <sub>K</sub>	Calibration: gain (can be activated via bit <a href="#">R32.5</a> [ <a href="#">▶ 50</a> ] of the feature register)	[1]	<a href="#">R2</a> [ <a href="#">▶ 48</a> ]
A <sub>GK</sub>	Basic calibration: gain (can be activated via bit <a href="#">R32.5</a> [ <a href="#">▶ 50</a> ] of the feature register)	[1]	<a href="#">R23</a> [ <a href="#">▶ 50</a> ]
B <sub>H</sub>	Vendor scaling: offset (can be activated via bit <a href="#">R32.1</a> [ <a href="#">▶ 50</a> ] of the feature register)	[1]	<a href="#">R19</a> [ <a href="#">▶ 50</a> ]
A <sub>H</sub>	Vendor scaling: gain (can be activated via bit <a href="#">R32.1</a> [ <a href="#">▶ 50</a> ] of the feature register)	$[1 \times 2^{-8} + 1]$	<a href="#">R20</a> [ <a href="#">▶ 50</a> ]
B <sub>W</sub>	User scaling: offset (can be activated via bit <a href="#">R32.0</a> [ <a href="#">▶ 50</a> ] of the feature register)	[1]	<a href="#">R33</a> [ <a href="#">▶ 52</a> ]
A <sub>W</sub>	User scaling: gain (can be activated via bit <a href="#">R32.0</a> [ <a href="#">▶ 50</a> ] of the feature register)	$[1 \times 2^{-8} + 1]$	<a href="#">R34</a> [ <a href="#">▶ 52</a> ]

**Calibration**

The analog channels are periodically subjected to self-calibration. In this process, the field signal is electrically separated from the internal acquisition (ADC); instead, internal reference voltages are applied and thus essential circuit parts are acquired. Only the near-field interference suppression elements (L/C combination) and the analog switches themselves cannot be acquired. The aim is to compensate for temperature drift effects.

**NOTE**

**External effect of the field separation**

The described separation of the internal circuit from the signal can cause interferences on the field signal! With normal, i.e. switched on measurement, a current flows through the KL31x2 in any case, which applies a load to the source. This is omitted while the terminal is in self-calibration. If necessary, check the behavior of the signal source (sensor, calibrator) with a separate measuring device in the load change moments, whether overvoltages/undervoltages or short-term glitches/peaks occur.

The calibration interval is set in register [R40](#) [[▶ 53](#)] in steps of 100 ms. During calibration

- no current process data are present. Value 0 is present.
- the terminal sets the [SB1.6](#) [[▶ 44](#)] in the status byte
- the RUN LED (green) is extinguished and Error (red) is set

Calibration can be disabled by the controller via control byte [CB1.1](#) [[▶ 44](#)] if necessary. If calibration is disabled over a prolonged period, the terminal carries out a forced calibration, in order to compensate any voltage drifts that may be caused by changes in temperature. The forced calibration interval is specified via register [R44](#) [[▶ 53](#)] as a multiple of the calibration interval. If a further calibration between two cycles is required, this can be started manually by setting bit [CB1.0](#) [[▶ 44](#)]. The terminal then acts as if it had triggered a calibration itself.

## ● **Fluctuating measuring signals interfere with self-calibration**

**I** In the calibration phase, the terminal uses a stabilization check to verify that the input signal is stable. Strongly fluctuating measuring signals prevent a termination of the self-calibration, it stops with Error=1 and Overload/Underload=1, see chapter [Basics of the function/ Calibration \[▶ 15\]](#) and [Access from the user program/ Status byte 1 \(for process data mode\) \[▶ 44\]](#).

If such a signal is expected at the system, the following can be selected

- the self-calibration via control bit [CB1.1 \[▶ 44\]](#) can be blocked in the process until a steady signal is applied and the self-calibration runs through.
- the stabilization check can be switched off with bit [R32.7 \[▶ 50\]](#).
- the stabilization error display can be switched off with bit [R32.14 \[▶ 50\]](#).
- the tolerance window [R48 \[▶ 53\]](#) of the stabilization control can be increased.

The functionality of the calibration including all features invariably refers to both channels simultaneously! The channels cannot be calibrated individually. For this reason, the registers [R40 \[▶ 53\]](#), [R44 \[▶ 53\]](#), [R47 \[▶ 53\]](#) and [R48 \[▶ 53\]](#) are only implemented once for both channels.

- In the first phase of the calibration, an input voltage of 0 V is applied to both analog inputs (zero calibration). The zero points of both analog input stages can be determined in this way. For this measurement, the respective absolute value of the channels is of interest. The value is subsequently stored in the RAM (register [R1 \[▶ 48\]](#)).
- During the second calibration phase, an internal reference voltage of approx. 1.8 V (final calibration) is applied to both analog inputs. In this case, it is no longer the absolute value of the measurement result that is of interest, but only any deviation from the basic calibration value determined during production (register [R23 \[▶ 50\]](#)). The ratio between the two values is calculated and used in the next [correction calculation \[▶ 14\]](#). The value is subsequently stored in the RAM (register [R2 \[▶ 48\]](#)).

### **Stabilization of the calibration**

During the calibration, a stabilization of the offset and gain values is carried out. The calibration values are only accepted once a certain number (specified via register [R47 \[▶ 53\]](#)) of measured values is inside a certain tolerance range (specified via register [R48 \[▶ 53\]](#)). This further increases the precision. This function can be deactivated via bit [R32.7 \[▶ 50\]](#).

### **Limit values**

The terminal offers the option of monitoring two limit values per channel. Limit value 1 can be specified via register [R35 \[▶ 52\]](#), and limit value 2 via register [R36 \[▶ 52\]](#). They are activated via bits in the feature registers [R32.9 \[▶ 50\]](#) and [R32.10 \[▶ 50\]](#). The status of the current process data value is indicated to the controller via the status byte [SB1 \[▶ 44\]](#). Possible states are: Process data equal limit value (3), process data less than limit value (2), process data greater than limit value (1).

### **Limiting the measuring range**

The terminal indicates any violation of the measuring range to the higher-level controller via the status byte.

- If the current measured value is larger than 0xFFFF or 0x7FFF, bit [SB1.1 \[▶ 44\]](#) is set.
- If the current measured value is less than 0 or 0x8000, bit [SB1.0 \[▶ 44\]](#) is set.

In both cases, the ERROR LED of the respective channel will be on. This function can be deactivated via bit [R32.8 \[▶ 50\]](#).

### **Differential measurement**

With the KL3132, KL3162, KL3172, KL3182, the differential measurement can be deactivated with bit [R32.6 \[▶ 50\]](#). Then, for channels 1 and 2, the input is internally switched to GND at terminal point 3/7, which must then be wired externally accordingly.



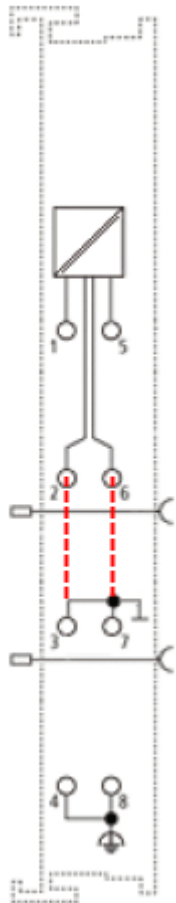



Fig. 4: Differential measuring

## 2.5 Continuitive documentation for I/O components with analog in and outputs

<b>NOTE</b>	
	<p><b>Continuitive documentation Continuitive documentation for I/O components with analog in and outputs</b></p> <p>Pay also attention to the continuative documentation</p> <p><b>I/O Analog Manual</b> Notes on I/O components with analog inputs and outputs, which is available for download on the Beckhoff homepage <a href="https://www.beckhoff.com">https://www.beckhoff.com</a> on the respective product pages!</p> <p>It explains the basics of sensor technology and contains notes on analog measured values.</p>

## 3 Mounting and wiring

### 3.1 Instructions for ESD protection

#### NOTE

##### **Destruction of the devices by electrostatic discharge possible!**

The devices contain components at risk from electrostatic discharge caused by improper handling.

- Please ensure you are electrostatically discharged and avoid touching the contacts of the device directly.
- Avoid contact with highly insulating materials (synthetic fibers, plastic film etc.).
- Surroundings (working place, packaging and personnel) should be grounded probably, when handling with the devices.
- Each assembly must be terminated at the right hand end with a KL9010 bus end terminal, to ensure the protection class and ESD protection.

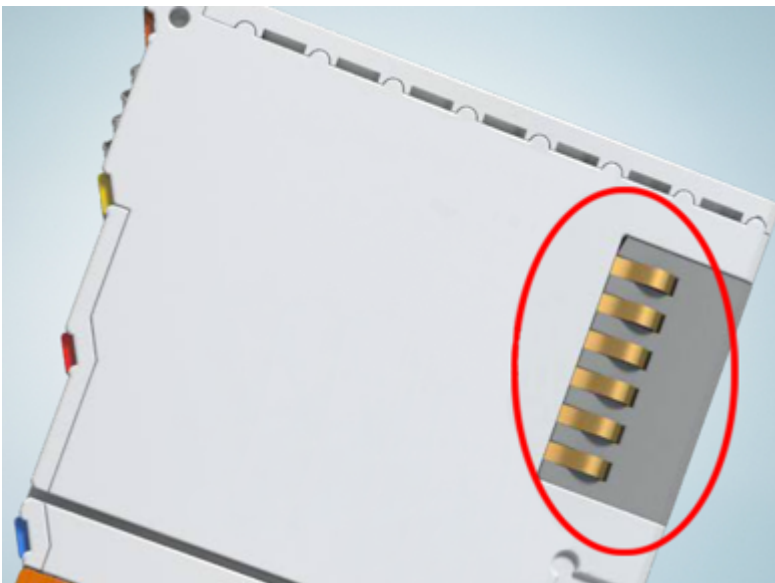

Fig. 5: Spring contacts of the Beckhoff I/O components

## 3.2 Installation on mounting rails

### ⚠ WARNING

#### Risk of electric shock and damage of device!

Bring the bus terminal system into a safe, powered down state before starting installation, disassembly or wiring of the bus terminals!

#### Assembly

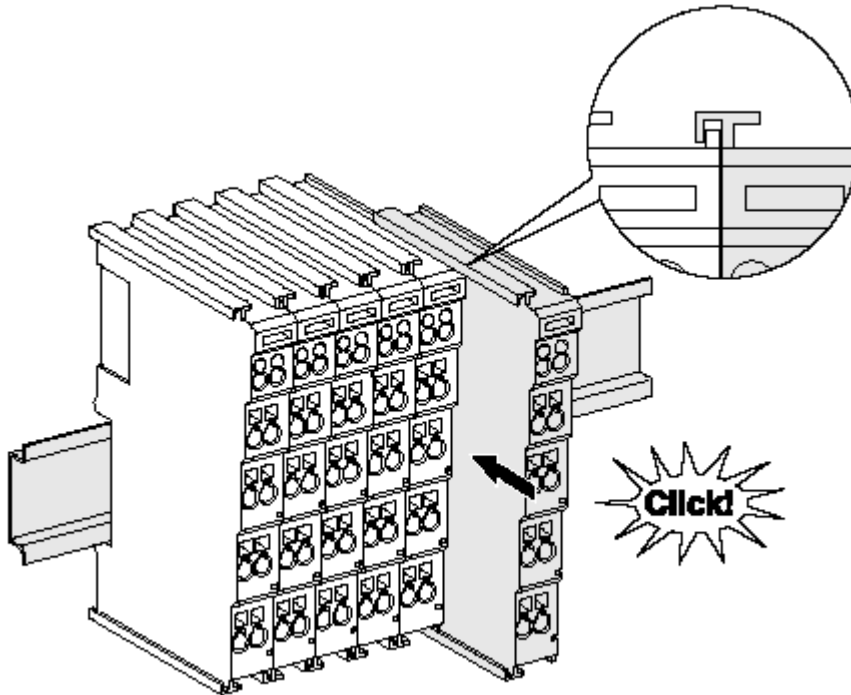

Fig. 6: Attaching on mounting rail

The bus coupler and bus terminals are attached to commercially available 35 mm mounting rails (DIN rails according to EN 60715) by applying slight pressure:

1. First attach the fieldbus coupler to the mounting rail.
2. The bus terminals are now attached on the right-hand side of the fieldbus coupler. Join the components with tongue and groove and push the terminals against the mounting rail, until the lock clicks onto the mounting rail.

If the terminals are clipped onto the mounting rail first and then pushed together without tongue and groove, the connection will not be operational! When correctly assembled, no significant gap should be visible between the housings.

#### **i** Fixing of mounting rails

The locking mechanism of the terminals and couplers extends to the profile of the mounting rail. At the installation, the locking mechanism of the components must not come into conflict with the fixing bolts of the mounting rail. To mount the mounting rails with a height of 7.5 mm under the terminals and couplers, you should use flat mounting connections (e.g. countersunk screws or blind rivets).

## Disassembly

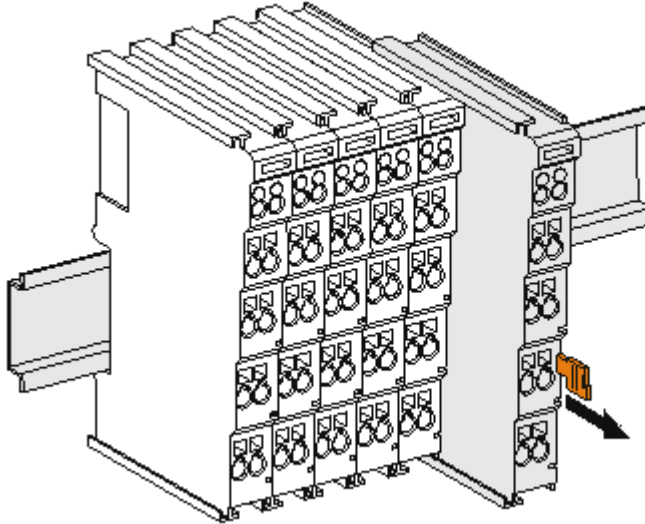

Fig. 7: Disassembling of terminal

Each terminal is secured by a lock on the mounting rail, which must be released for disassembly:

1. Pull the terminal by its orange-colored lugs approximately 1 cm away from the mounting rail. In doing so for this terminal the mounting rail lock is released automatically and you can pull the terminal out of the bus terminal block easily without excessive force.
2. Grasp the released terminal with thumb and index finger simultaneous at the upper and lower grooved housing surfaces and pull the terminal out of the bus terminal block.

## Connections within a bus terminal block

The electric connections between the Bus Coupler and the Bus Terminals are automatically realized by joining the components:

- The six spring contacts of the K-Bus/E-Bus deal with the transfer of the data and the supply of the Bus Terminal electronics.
- The power contacts deal with the supply for the field electronics and thus represent a supply rail within the bus terminal block. The power contacts are supplied via terminals on the Bus Coupler (up to 24 V) or for higher voltages via power feed terminals.

### **i** Power Contacts

During the design of a bus terminal block, the pin assignment of the individual Bus Terminals must be taken account of, since some types (e.g. analog Bus Terminals or digital 4-channel Bus Terminals) do not or not fully loop through the power contacts. Power Feed Terminals (KL91xx, KL92xx or EL91xx, EL92xx) interrupt the power contacts and thus represent the start of a new supply rail.

## PE power contact

The power contact labeled PE can be used as a protective earth. For safety reasons this contact mates first when plugging together, and can ground short-circuit currents of up to 125 A.

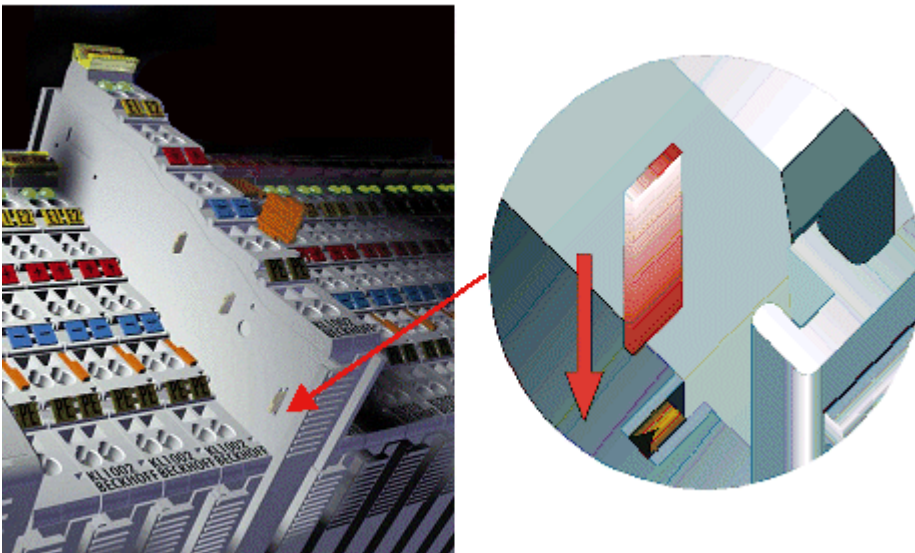

Fig. 8: Power contact on left side

**NOTE**

**Possible damage of the device**

Note that, for reasons of electromagnetic compatibility, the PE contacts are capacitatively coupled to the mounting rail. This may lead to incorrect results during insulation testing or to damage on the terminal (e.g. disruptive discharge to the PE line during insulation testing of a consumer with a nominal voltage of 230 V). For insulation testing, disconnect the PE supply line at the Bus Coupler or the Power Feed Terminal! In order to decouple further feed points for testing, these Power Feed Terminals can be released and pulled at least 10 mm from the group of terminals.

**⚠ WARNING**

**Risk of electric shock!**

The PE power contact must not be used for other potentials!

**3.3 Disposal**



Products marked with a crossed-out wheeled bin shall not be discarded with the normal waste stream. The device is considered as waste electrical and electronic equipment. The national regulations for the disposal of waste electrical and electronic equipment must be observed.

## 3.4 Connection

### 3.4.1 Connection system

#### ⚠ WARNING

##### Risk of electric shock and damage of device!

Bring the bus terminal system into a safe, powered down state before starting installation, disassembly or wiring of the bus terminals!

#### Overview

The bus terminal system offers different connection options for optimum adaptation to the respective application:

- The terminals of ELxxxx and KLxxxx series with standard wiring include electronics and connection level in a single enclosure.
- The terminals of ESxxxx and KSxxxx series feature a pluggable connection level and enable steady wiring while replacing.
- The High Density Terminals (HD Terminals) include electronics and connection level in a single enclosure and have advanced packaging density.

#### Standard wiring (ELxxxx / KLxxxx)



Fig. 9: Standard wiring

The terminals of ELxxxx and KLxxxx series have been tried and tested for years. They feature integrated screwless spring force technology for fast and simple assembly.

#### Pluggable wiring (ESxxxx / KSxxxx)



Fig. 10: Pluggable wiring

The terminals of ESxxxx and KSxxxx series feature a pluggable connection level. The assembly and wiring procedure is the same as for the ELxxxx and KLxxxx series. The pluggable connection level enables the complete wiring to be removed as a plug connector from the top of the housing for servicing. The lower section can be removed from the terminal block by pulling the unlocking tab. Insert the new component and plug in the connector with the wiring. This reduces the installation time and eliminates the risk of wires being mixed up.

The familiar dimensions of the terminal only had to be changed slightly. The new connector adds about 3 mm. The maximum height of the terminal remains unchanged.

A tab for strain relief of the cable simplifies assembly in many applications and prevents tangling of individual connection wires when the connector is removed.

Conductor cross sections between 0.08 mm<sup>2</sup> and 2.5 mm<sup>2</sup> can continue to be used with the proven spring force technology.

The overview and nomenclature of the product names for ESxxxx and KSxxxx series has been retained as known from ELxxxx and KLxxxx series.

### High Density Terminals (HD Terminals)



Fig. 11: High Density Terminals

The terminals from these series with 16 terminal points are distinguished by a particularly compact design, as the packaging density is twice as large as that of the standard 12 mm bus terminals. Massive conductors and conductors with a wire end sleeve can be inserted directly into the spring loaded terminal point without tools.

---

#### ● Wiring HD Terminals



The High Density Terminals of the ELx8xx and KLx8xx series doesn't support pluggable wiring.

---

### Ultrasonically “bonded” (ultrasonically welded) conductors

---

#### ● Ultrasonically “bonded” conductors



It is also possible to connect the Standard and High Density Terminals with ultrasonically “bonded” (ultrasonically welded) conductors. In this case, please note the tables concerning the wire-size width [► 24]!

---

### 3.4.2 Wiring

#### ⚠ WARNING

#### Risk of electric shock and damage of device!

Bring the bus terminal system into a safe, powered down state before starting installation, disassembly or wiring of the bus terminals!

#### Terminals for standard wiring ELxxxx/KLxxxx and for pluggable wiring ESxxxx/KSxxxx

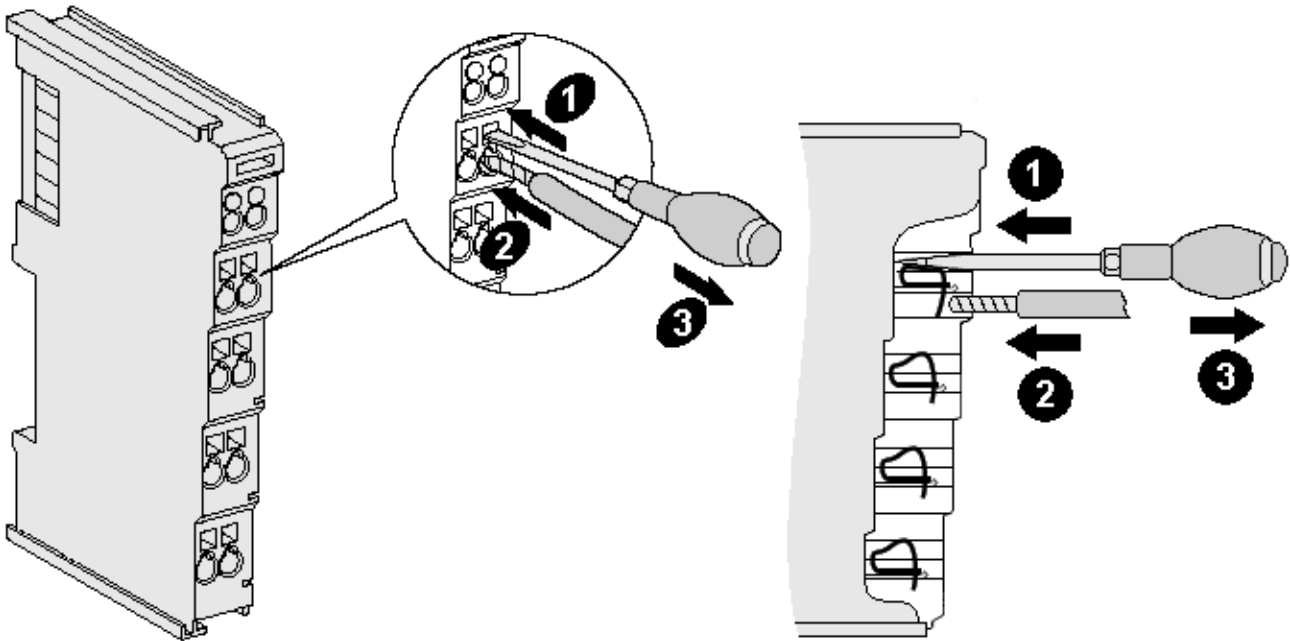

Fig. 12: Connecting a cable on a terminal point

Up to eight terminal points enable the connection of solid or finely stranded cables to the bus terminal. The terminal points are implemented in spring force technology. Connect the cables as follows:

1. Open a terminal point by pushing a screwdriver straight against the stop into the square opening above the terminal point. Do not turn the screwdriver or move it alternately (don't toggle).
2. The wire can now be inserted into the round terminal opening without any force.
3. The terminal point closes automatically when the pressure is released, holding the wire securely and permanently.

See the following table for the suitable wire size width.

Terminal housing	ELxxxx, KLxxxx	ESxxxx, KSxxxx
Wire size width (single core wires)	0.08 ... 2.5 mm <sup>2</sup>	0.08 ... 2.5 mm <sup>2</sup>
Wire size width (fine-wire conductors)	0.08 ... 2.5 mm <sup>2</sup>	0.08 ... 2.5 mm <sup>2</sup>
Wire size width (conductors with a wire end sleeve)	0.14 ... 1.5 mm <sup>2</sup>	0.14 ... 1.5 mm <sup>2</sup>
Wire stripping length	8 ... 9 mm	9 ... 10 mm

#### High Density Terminals (HD Terminals [[▶ 23](#)]) with 16 terminal points

The conductors of the HD Terminals are connected without tools for single-wire conductors using the direct plug-in technique, i.e. after stripping the wire is simply plugged into the terminal point. The cables are released, as usual, using the contact release with the aid of a screwdriver. See the following table for the suitable wire size width.



Terminal housing	High Density Housing
Wire size width (single core wires)	0.08 ... 1.5 mm <sup>2</sup>
Wire size width (fine-wire conductors)	0.25 ... 1.5 mm <sup>2</sup>
Wire size width (conductors with a wire end sleeve)	0.14 ... 0.75 mm <sup>2</sup>
Wire size width (ultrasonically "bonded" conductors)	only 1.5 mm <sup>2</sup> (see notice [▶ 23])
Wire stripping length	8 ... 9 mm

### 3.4.3 Shielding



#### Shielding

Encoder, analog sensors and actuators should always be connected with shielded, twisted paired wires.

### 3.4.4 Contact assignment

**⚠ WARNING**

**Risk of injury through electric shock and damage to the device!**

Bring the Bus Terminals system into a safe, de-energized state before starting mounting, disassembly or wiring of the Bus Terminals!

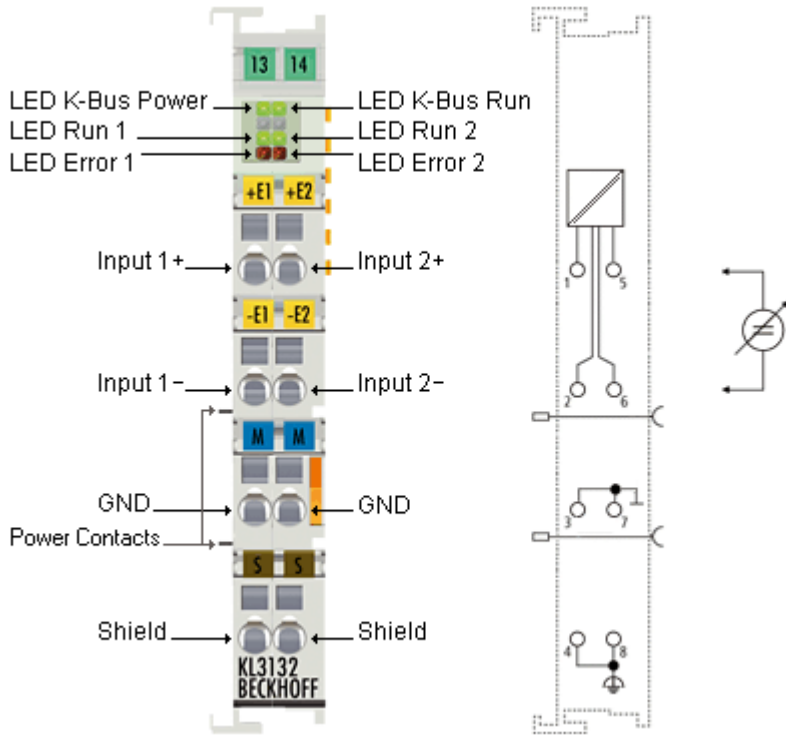

Fig. 13: KL3132 - Contact assignment

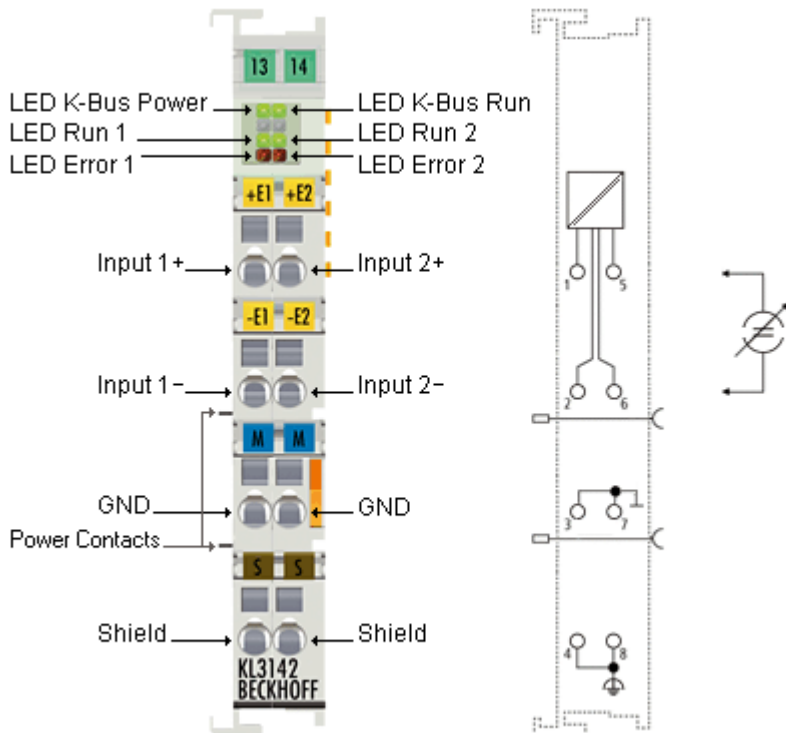

Fig. 14: KL3142 - Contact assignment

Terminal point	No.	Connection for
Input 1+	1	+ input channel 1
Input 1-	2	- input channel 1
GND	3	Internal ground (internally connected to terminal point 7)
Shield	4	PE contact (internally connected to terminal point 8)
Input 2+	5	+ input channel 2
Input 2-	6	- input channel 2
GND	7	Internal ground (internally connected to terminal point 3)
Shield	8	PE contact (internally connected to terminal point 4)

**NOTE****Power contacts connected to the next terminal**

In hardware version 01 or higher, two power contacts are connected to the next terminal. However, they are not used by the KL31x2.

Please be aware of this when you update from hardware version 00.

The hardware version of your terminal is indicated by the serial number [► 7], which is printed on the side of the terminal.

### 3.5 ATEX - Special conditions (standard temperature range)

#### ⚠ WARNING

**Observe the special conditions for the intended use of Beckhoff fieldbus components with standard temperature range in potentially explosive areas (directive 2014/34/EU)!**

- The certified components are to be installed in a suitable housing that guarantees a protection class of at least IP54 in accordance with EN 60079-15! The environmental conditions during use are thereby to be taken into account!
- For dust (only the fieldbus components of certificate no. KEMA 10ATEX0075 X Issue 9): The equipment shall be installed in a suitable enclosure providing a degree of protection of IP54 according to EN 60079-31 for group IIIA or IIIB and IP6X for group IIIC, taking into account the environmental conditions under which the equipment is used!
- If the temperatures during rated operation are higher than 70°C at the feed-in points of cables, lines or pipes, or higher than 80°C at the wire branching points, then cables must be selected whose temperature data correspond to the actual measured temperature values!
- Observe the permissible ambient temperature range of 0 to 55°C for the use of Beckhoff fieldbus components standard temperature range in potentially explosive areas!
- Measures must be taken to protect against the rated operating voltage being exceeded by more than 40% due to short-term interference voltages!
- The individual terminals may only be unplugged or removed from the Bus Terminal system if the supply voltage has been switched off or if a non-explosive atmosphere is ensured!
- The connections of the certified components may only be connected or disconnected if the supply voltage has been switched off or if a non-explosive atmosphere is ensured!
- The fuses of the KL92xx/EL92xx power feed terminals may only be exchanged if the supply voltage has been switched off or if a non-explosive atmosphere is ensured!
- Address selectors and ID switches may only be adjusted if the supply voltage has been switched off or if a non-explosive atmosphere is ensured!

#### Standards

The fundamental health and safety requirements are fulfilled by compliance with the following standards:

- EN 60079-0:2012+A11:2013
- EN 60079-15:2010
- EN 60079-31:2013 (only for certificate no. KEMA 10ATEX0075 X Issue 9)

#### Marking

The Beckhoff fieldbus components with standard temperature range certified according to the ATEX directive for potentially explosive areas bear one of the following markings:



**II 3G KEMA 10ATEX0075 X Ex nA IIC T4 Gc Ta: 0 ... +55°C**

II 3D KEMA 10ATEX0075 X Ex tc IIIC T135°C Dc Ta: 0 ... +55°C  
(only for fieldbus components of certificate no. KEMA 10ATEX0075 X Issue 9)

or



**II 3G KEMA 10ATEX0075 X Ex nA nC IIC T4 Gc Ta: 0 ... +55°C**

II 3D KEMA 10ATEX0075 X Ex tc IIIC T135°C Dc Ta: 0 ... +55°C  
(only for fieldbus components of certificate no. KEMA 10ATEX0075 X Issue 9)

## 3.6 Continulative documentation for ATEX and IECEx

### NOTE



#### **Continulative documentation about explosion protection according to ATEX and IECEx**

Pay also attention to the continuative documentation

#### **Ex. Protection for Terminal Systems**

Notes on the use of the Beckhoff terminal systems in hazardous areas according to ATEX and IECEx,

that is available for [download](#) within the download area of your product on the Beckhoff homepage [www.beckhoff.com](http://www.beckhoff.com)!

### 3.7 Application example for KL3172-0000

**⚠ WARNING**

**Risk of injury through electric shock and damage to the device!**

Bring the Bus Terminals system into a safe, de-energized state before starting mounting, disassembly or wiring of the Bus Terminals!

Monitoring the cell voltages of a battery with several KL3172.

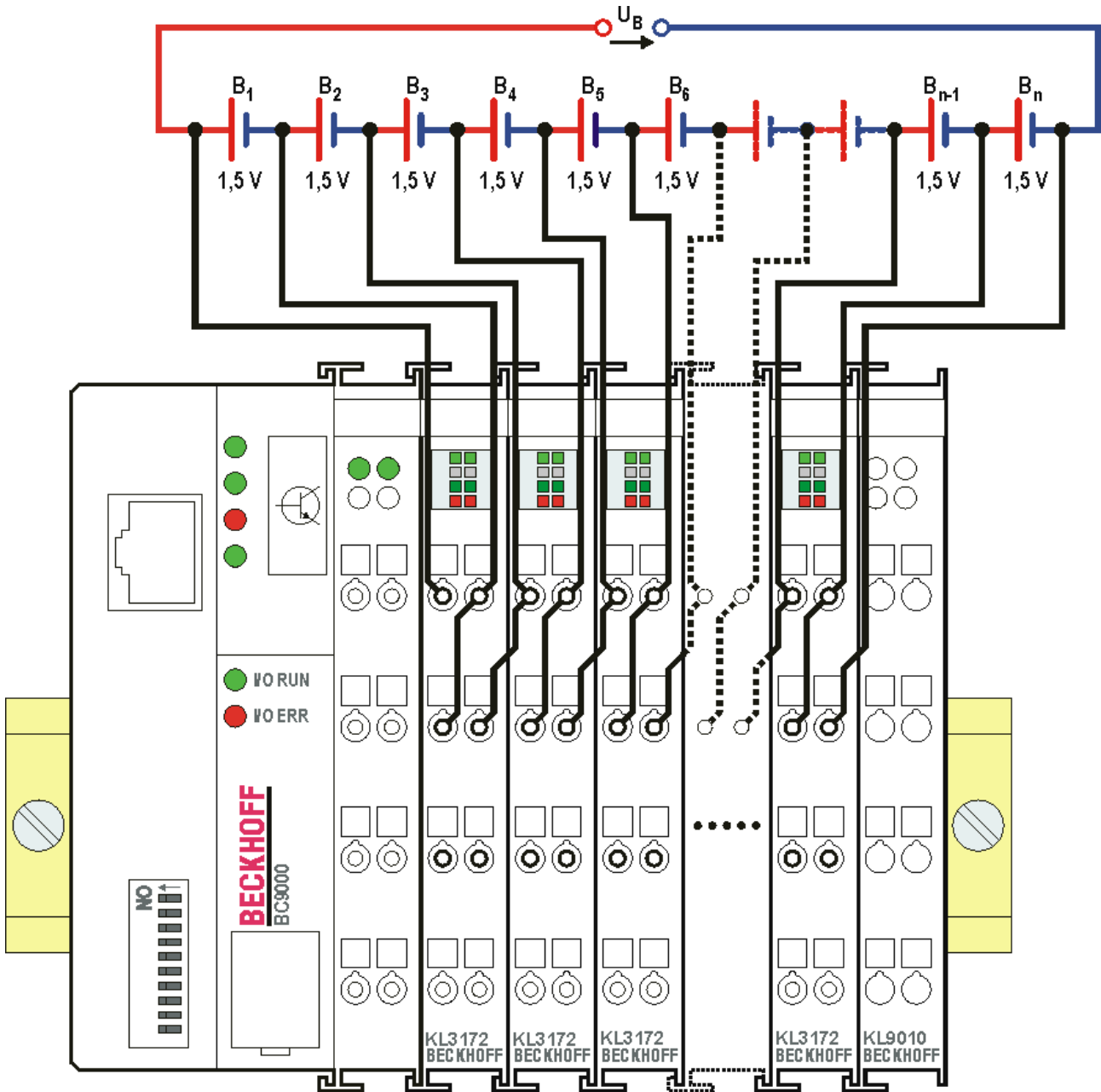

Fig. 15: KL3172-0000 - application example

**NOTE**

**Do not exceed the dielectric strength!**

Please note that the sum of the cell voltages (in the example  $U_B = n \times 1.5 \text{ V}$ ) must not exceed the dielectric strength (electrical isolation  $\rightarrow$  10] 500 V) of the KL3172!

## 4 Configuration Software KS2000

### 4.1 KS2000 - Introduction

The KS2000 configuration software permits configuration, commissioning and parameterization of bus couplers, of the affiliated bus terminals and of Fieldbus Box Modules. The connection between bus coupler / Fieldbus Box Module and the PC is established by means of the serial configuration cable or the fieldbus.



Fig. 16: KS2000 configuration software

#### Configuration

You can configure the Fieldbus stations with the Configuration Software KS2000 offline. That means, setting up a terminal station with all settings on the couplers and terminals resp. the Fieldbus Box Modules can be prepared before the commissioning phase. Later on, this configuration can be transferred to the terminal station in the commissioning phase by means of a download. For documentation purposes, you are provided with the breakdown of the terminal station, a parts list of modules used and a list of the parameters you have modified. After an upload, existing fieldbus stations are at your disposal for further editing.

#### Parameterization

KS2000 offers simple access to the parameters of a fieldbus station: specific high-level dialogs are available for all bus couplers, all intelligent bus terminals and Fieldbus Box modules with the aid of which settings can be modified easily. Alternatively, you have full access to all internal registers of the bus couplers and intelligent terminals. Refer to the register description for the meanings of the registers.

## Commissioning

The KS2000 software facilitates commissioning of machine components or their fieldbus stations: Configured settings can be transferred to the fieldbus modules by means of a download. After a *login* to the terminal station, it is possible to define settings in couplers, terminals and Fieldbus Box modules directly *online*. The same high-level dialogs and register access are available for this purpose as in the configuration phase.

The KS2000 offers access to the process images of the bus couplers and Fieldbus Box modules.

- Thus, the coupler's input and output images can be observed by monitoring.
- Process values can be specified in the output image for commissioning of the output modules.

All possibilities in the *online mode* can be used in parallel with the actual fieldbus mode of the terminal station. The fieldbus protocol always has the higher priority in this case.



## 4.2 Parameterization with KS2000

Connect the configuration interface of your fieldbus coupler with the serial interface of your PC via the configuration cable and start the *KS2000* Configuration Software.



Click on the *Login* button. The configuration software will now load the information for the connected fieldbus station.

In the example shown, this is

- a Ethernet Coupler BK9000
- a digital input terminal KL1xx2
- a precise two-channel analog input terminal for signals between 0 and 2 V, KL3172
- a bus end terminal KL9010

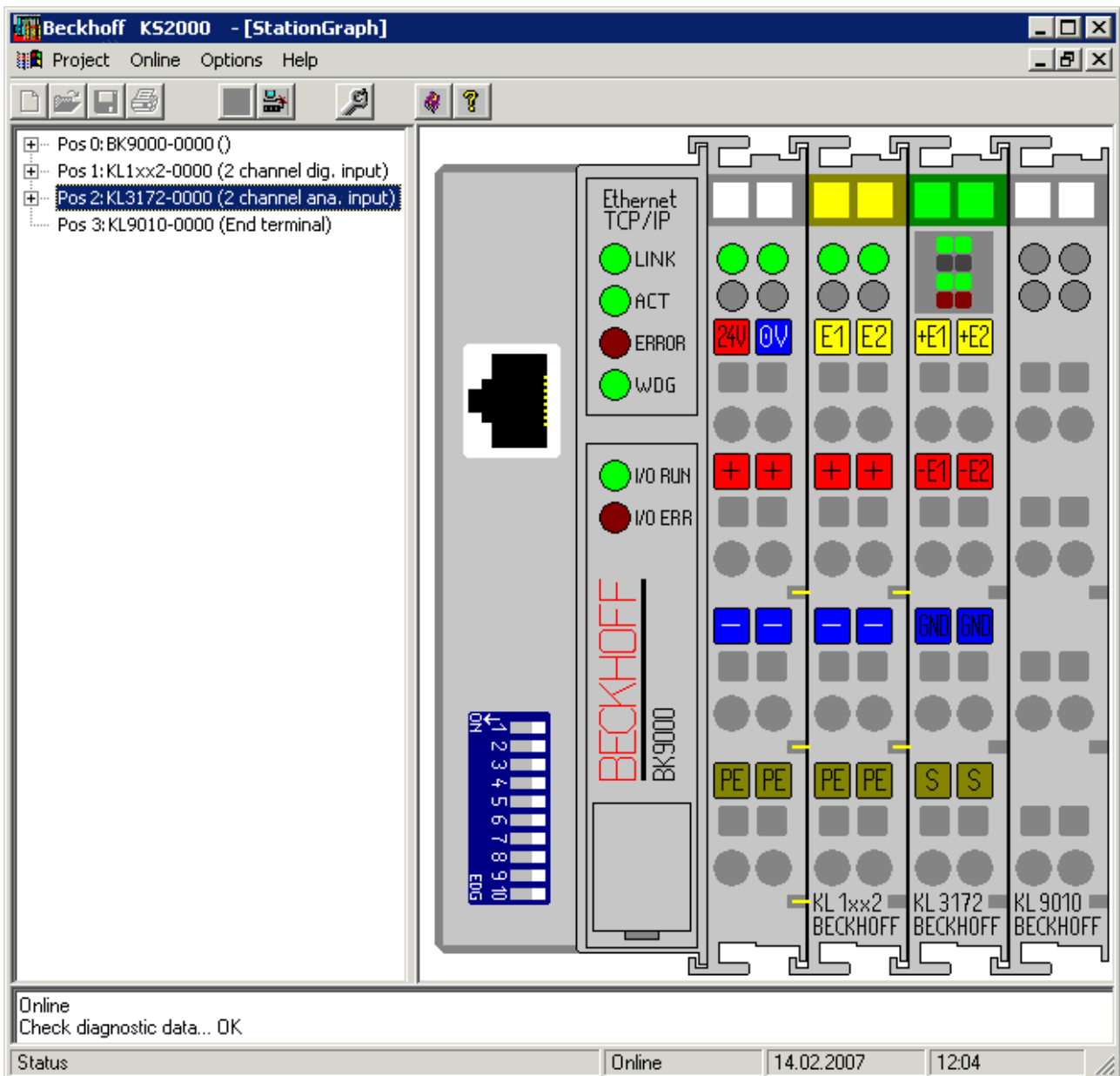

Fig. 17: Display of the fieldbus station in KS2000

The left-hand KS2000 window displays the terminals of the fieldbus station in a tree structure. The right-hand KS2000 window contains a graphic display of the fieldbus station terminals.

In the tree structure of the left-hand window, click on the plus-sign next to the terminal whose parameters you wish to change (item 2 in the example).

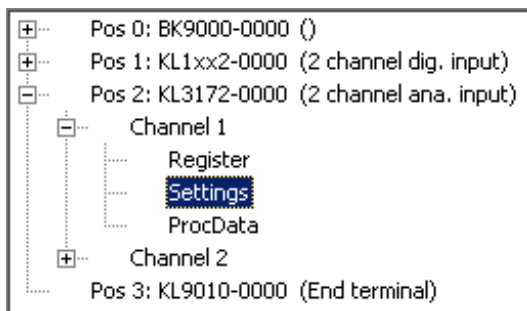

Fig. 18: KS2000 branch for channel 1 of the KL3172

For the KL3172, the branches *Register*, *Settings* and *ProcData* are displayed:

- [Register \[► 35\]](#) enables direct access to the KL3172 registers.
- A dialog mask for the parameterization of the KL3172 can be found under [Settings \[► 36\]](#).
- ProcData displays the KL3172 process data.

### 4.3 Register

You can access the registers of the KL3172 directly under *Register*. The meaning of the register is explained in the [register overview](#) [▶ 47].

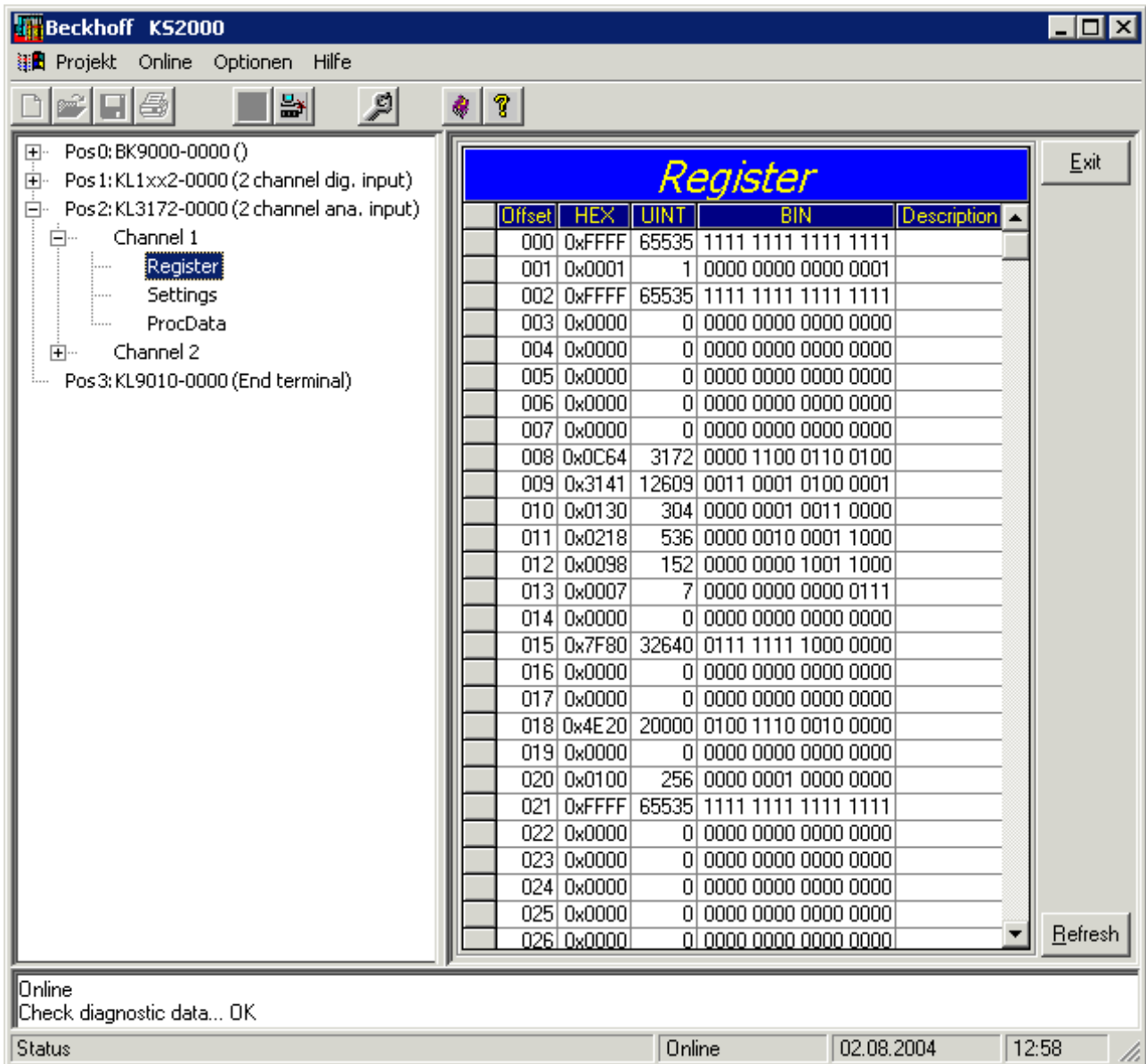

Fig. 19: Register view in KS2000

## 4.4 Settings

The dialog mask for the parameterization of the KL3172 can be found under *Settings*.

Pos.: 2                      Channel: 1  
Type: KL3172-0000

Take settings for all channels of this terminal

**Operation mode**

- Channel disabled
- User scaling active
- Manufacturer scaling active
- Watchdog timer active
- Signed amount representation
- Siemens output format
- Calibration active
- Differential measurement active
- Stabilization of calibration active
- Overrange protection
- Threshold 1 active
- Threshold 2 active

**Register values**

User offset

User gain

Calibration interval

Forced calibration interval

Number of stable measured values

Tolerance for measurand stability

Threshold 1

Threshold 2

Filter constant

FASTStep (TM) mode enabled

FIR filter enabled

Fig. 20: Settings via KS2000

### Operation mode

#### Channel disabled ([R32.11](#) [[▶ 50](#)])

Here you can disable this channel, in order facilitate a faster cycle time for the other channel (default: not disabled).

Disabling of a channel is indicated by its Run and error LEDs going out.

#### User scaling active ([R32.0](#) [[▶ 50](#)])

You can activate user scaling here (default: deactivated).

#### Manufacturer scaling active ([R32.1](#) [[▶ 50](#)])

You can activate manufacturer scaling here (default: deactivated).

#### Watchdog timer active ([R32.2](#) [[▶ 50](#)])

You can deactivate the watchdog timer here (default: activated).

#### Signed amount representation ([R32.3](#) [[▶ 50](#)])

You can activate the signed amount representation here (default: deactivated).

**Siemens output format (R32.4 [[▶](#) 50])**

You can activate Siemens output format here (default: deactivated).

**Calibration active (R32.5 [[▶](#) 50])**

You can deactivate the calibration here (default: activated).

**Differential measurement (R32.6 [[▶](#) 50])**

You can deactivate the differential measurement here (default: activated).

**Stabilization of calibration active (R32.7 [[▶](#) 50])**

You can deactivate the stabilization of the calibration here (default: activated).

**Limitation of the measuring range active (R32.8 [[▶](#) 50])**

You can deactivate the limitation of the measuring range here (default: activated).

**Limit value 1 active (R32.9 [[▶](#) 50])**

You can activate the limit value 1 here (default: deactivated).

**Limit value 2 active (R32.10 [[▶](#) 50])**

You can activate the limit value 2 here (default: deactivated).

**Register values****User offset (R33 [[▶](#) 52])**

You can specify the user offset between -32768 and 32767 here (default: 0).

**User gain (R34 [[▶](#) 52])**

You can specify the user gain between 0 and 65535 here (default: 256, corresponding to a factor of 1).

**Calibration interval (R40 [[▶](#) 53])**

You can specify the calibration interval for the reference signal here in steps of 100 ms (default: 300 s).

**Forced calibration interval (R44 [[▶](#) 53])**

You can specify the interval for the forced calibration here. This interval is always a multiple (default: 3<sub>dez</sub>) of the calibration interval. The interval for forced calibration when the terminal leaves the factory is therefore  $3 \times 180 \text{ s} = 900 \text{ s}$ .

**Number of stable measured values (R47 [[▶](#) 53])**

You can specify the number of measured values used for the calibration here (default: 50).

**Tolerance for measured value stability (R48 [[▶](#) 53])**

You can specify the stable measured value tolerance for the calibration here (default: 5).

**Limit value 1 (R35 [[▶](#) 52])**

You can specify the limit value 1 here (default: 0).

**Limit value 2 (R36 [▶ 52])**

You can specify the limit value 2 here (default: 0).

**Filter constant (R37.11-R37.4 [▶ 52])**

The filter constant  $SF$  specifies the 3dB limit frequency of the sinc<sup>3</sup> filter (default: 860<sub>dec</sub>).

**Fast-Step Mode<sup>(TM)</sup> enabled (R37.0 [▶ 52])**

You can activate Fast Step Mode here (default: deactivated). A fast reaction to jumps at the input follows in fast step mode, in spite of the filter stage being active. In this case the filter is bypassed!

**FIR filter active (R37.1 [▶ 52])**

You can deactivate the FIR filter here (default: activated).

## 4.5 Sample program for register communication via EtherCAT on KL3314 exemplary

### ● Using the sample programs



This document contains sample applications of our products for certain areas of application. The application notes provided here are based on typical features of our products and only serve as examples. The notes contained in this document explicitly do not refer to specific applications. The customer is therefore responsible for assessing and deciding whether the product is suitable for a particular application. We accept no responsibility for the completeness and correctness of the source code contained in this document. We reserve the right to modify the content of this document at any time and accept no responsibility for errors and missing information.

### Program description / function

This example program (TwinCAT 3) provides change of single register values of the KL3314 as selection of the element type, characteristic settings of the feature register R32 [▶ 50] and user scaling offset and gain (R33 [▶ 52] / R34 [▶ 52]) similar as per KS2000 [▶ 31] Configuration Software.

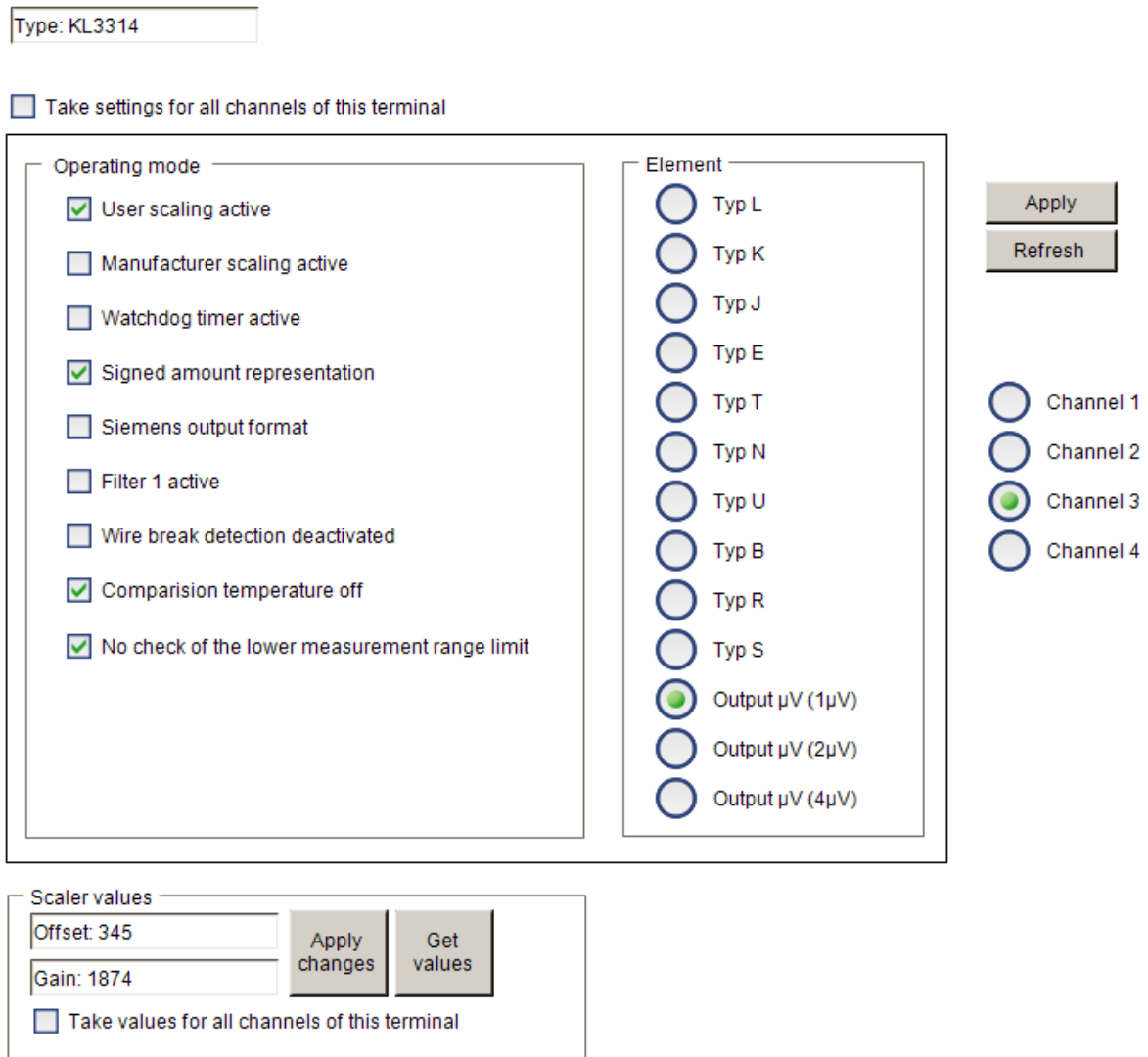



Fig. 21: Settings of KL3314 via visualization of TwinCAT 3

At least following configuration setup shall be present:

[coupler (e.g. BK1120) or embedded PC] + KL3314 + KL9010.

 Download:  
<https://infosys.beckhoff.com/content/1033/kl31x2/Resources/5996114571/.zip>

**Preparations for starting the sample programs (tzip file / TwinCAT 3)**

- Click on the download button to save the Zip archive locally on your hard disk, then unzip the \*.tzip archive file in a temporary folder.

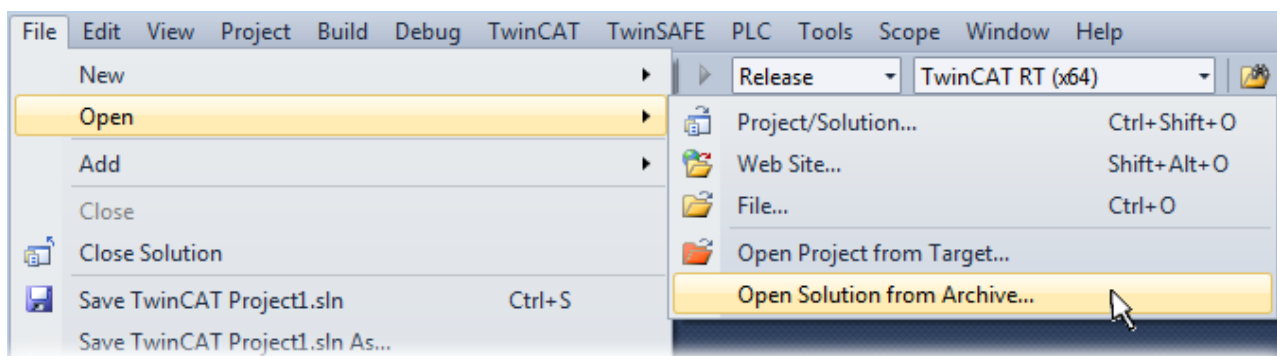

Fig. 22: Opening the \*. tzip archive

- Select the .tnzip file (sample program).
- A further selection window opens. Select the destination directory for storing the project.
- For a description of the general PLC commissioning procedure and starting the program please refer to the terminal documentation or the EtherCAT system documentation.
- The EtherCAT device of the example should usually be declared your present system. After selection of the EtherCAT device in the “Solutionexplorer” select the “Adapter” tab and click on “Search...”:

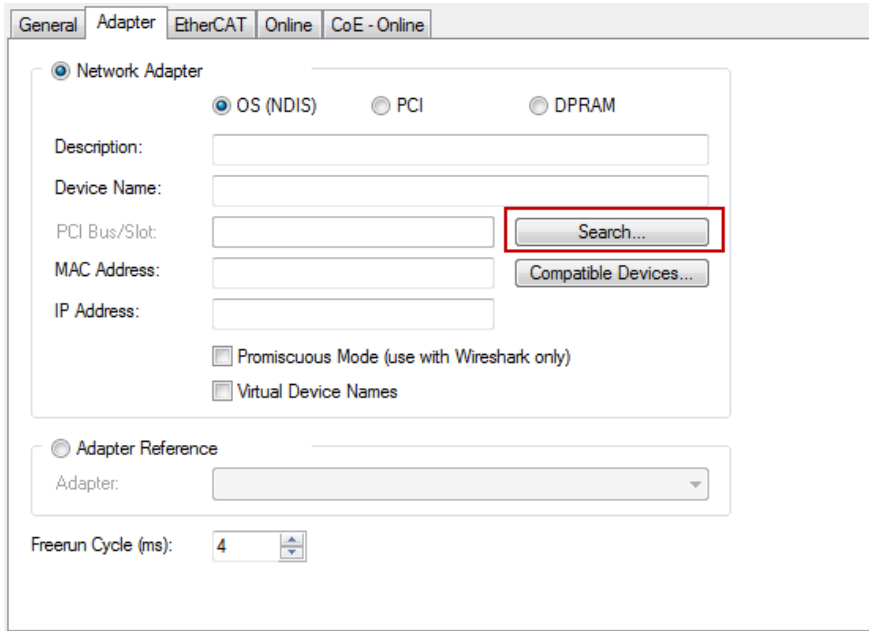
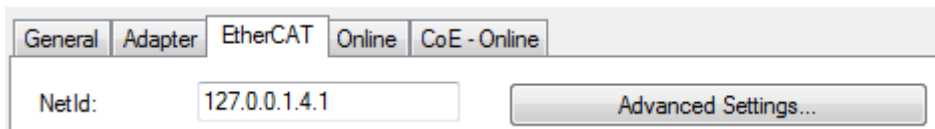

Fig. 23: Search of the existing HW configuration for the EtherCAT configuration of the example

- Checking NetId: the “EtherCAT” tab of the EtherCAT device shows the configured NetId:



The first four numbers must be identical with the project NetId of the target system. The project NetId can be viewed within the TwinCAT environment above, where a pull down menu can be opened to choose a target system (by clicking right in the text field). The number blocks are placed in brackets there next to each computer name of a target system.

- Modify the NetId: By right clicking on “EtherCAT device” within the solution explorer a context menu opens where “Change NetId...” have to be selected. The first four numbers of the NetId of the target computer must be entered; both last values are 4.1 usually.

Example:

- NetId of project: myComputer (123.45.67.89.1.1)
- Entry via „Change NetId...“: 123.45.67.89.4.1



## 5 Data structures

### 5.1 Process image

The terminals KL3132, KL3162, KL3142, KL3152 KL3172 and KL3148 are represented in the process image with a maximum of 6 bytes of input data and 6 bytes of output data. These are organized as follows:

Format	Input data	Output data
Byte	SB1 [ <a href="#">▶ 44</a> ]	CB1 [ <a href="#">▶ 44</a> ]
Word	DataIN1	DataOUT1
Byte	SB2 [ <a href="#">▶ 46</a> ]	CB2 [ <a href="#">▶ 46</a> ]
Word	DataIN2	DataOUT2

#### Key

SB n: Status byte for channel n  
 CB n: Control byte for channel n

DataIN n: Input data word channel n  
 DataOUT n: Output data word channel n

- Please refer to the [Mapping \[\[▶ 42\]\(#\)\]](#) page for the allocation of the bytes and words to the addresses of the controller.
- The meaning of the control and status bytes is explained in *Control and status bytes*.
- In process data mode the analog values are transferred in output data words DataIN1 and DataIN2. Input data words DataOUT1 and DataOUT2 are not used.

#### Representation of the analog values

The analog input values are represented by the terminals as follows:

##### KL3132-0000

Voltage	Decimal	Hexadecimal
-10 V	-32768	0x8000
+10 V	+32767	0x7FFF

##### KL3142-0000

Current	Decimal	Hexadecimal
0 mA	0	0x0000
20 mA	65535	0xFFFF

##### KL3152-0000

Current	Decimal	Hexadecimal
4 mA	0	0x0000
20 mA	65535	0xFFFF

##### KL3162-0000

Voltage	Decimal	Hexadecimal
0 V	0	0x0000
10 V	65535	0xFFFF

**KL3172-0000**

Voltage	Decimal	Hexadecimal
0 V	0	0x0000
2 V	65535	0xFFFF

**KL3172-0500**

Voltage	Decimal	Hexadecimal
0 V	0	0x0000
500 mV	65535	0xFFFF

**KL3172-1000**

Voltage	Decimal	Hexadecimal
0 V	0	0x0000
1 V	65535	0xFFFF

**KL3182-0000**

Voltage	Decimal	Hexadecimal
-2 V	-32768	0x8000
+2 V	+32767	0x7FFF

## 5.2 Mapping

The Bus Terminals occupy addresses within the process image of the controller. The assignment of process data (input and output data) and parameterization data (control and status bytes) to the control addresses is called mapping. The type of mapping depends on:

- the fieldbus system used
- the terminal type
- the parameterization of the Bus Coupler (conditions) such as
  - compact or full evaluation
  - Intel or Motorola format
  - word alignment switched on or off

The Bus Couplers (BKxxxx, LCxxxx) and Bus Terminal Controllers (BCxxxx, BXxxxx) are supplied with certain default settings. The default setting can be changed with the KS2000 configuration software or with a master configuration software (e.g. TwinCAT System Manager or ComProfibus).

The following tables show the mapping depending on different conditions. For information about the contents of the individual bytes please refer to the pages *Process image* and *Control and status byte*.

### Compact evaluation

For compact evaluation, the analog input terminals only occupy addresses in the input process image. Control and status bytes cannot be accessed.

### Compact evaluation in Intel format

Default mapping for CANopen, CANCEL, DeviceNet, ControlNet, Modbus, RS232 and RS485 coupler

	Address	Input data		Output data	
Requirements	Word offset	High byte	Low byte	High byte	Low byte
Complete evaluation: no Motorola format: no Word alignment: any	0	Ch1 D1	Ch1 D0	-	-
	1	Ch2 D1	Ch2 D0	-	-

**Compact evaluation in Motorola format**

Default mapping for PROFIBUS and Interbus coupler

	Address	Input data		Output data	
Requirements	Word offset	High byte	Low byte	High byte	Low byte
Complete evaluation: no Motorola format: yes Word alignment: any	0	Ch1 D0	Ch1 D1	-	-
	1	Ch2 D0	Ch2 D1	-	-

**Complete evaluation**

For complete evaluation, the analog input terminals occupy addresses in the input and output process image. Control and status bytes can be accessed.

**Complete evaluation in Intel format**

	Address	Input data		Output data	
Requirements	Word offset	High byte	Low byte	High byte	Low byte
Complete evaluation: yes Motorola format: no Word alignment: no	0	Ch1 D0	SB1	Ch1 D0	CB1
	1	SB2	Ch1 D1	CB2	Ch1 D1
	2	Ch2 D1	Ch2 D0	Ch2 D1	Ch2 D0

**Complete evaluation in Motorola format**

	Address	Input data		Output data	
Requirements	Word offset	High byte	Low byte	High byte	Low byte
Complete evaluation: yes Motorola format: yes Word alignment: no	0	Ch1 D1	SB1	Ch1 D1	CB1
	1	SB2	Ch1 D0	CB2	Ch1 D0
	2	Ch2 D0	Ch2 D1	Ch2 D0	Ch2 D1

**Complete evaluation in Intel format with word alignment**

Default mapping for Lightbus, EtherCAT and Ethernet coupler as well as Bus Terminal Controllers (BCxxxx, BXxxxx)

	Address	Input data		Output data	
Requirements	Word offset	High byte	Low byte	High byte	Low byte
Complete evaluation: yes Motorola format: no Word alignment: yes	0	reserved	SB1	reserved	CB1
	1	Ch1 D1	Ch1 D0	Ch1 D1	Ch1 D0
	2	reserved	SB2	reserved	CB2
	3	Ch2 D1	Ch2 D0	Ch2 D1	Ch2 D0

**Complete evaluation in Motorola format with word alignment**

Requirements	Address	Input data		Output data	
	Word offset	High byte	Low byte	High byte	Low byte
Complete evaluation: yes	0	reserved	SB1	reserved	CB1
Motorola format: yes	1	Ch1 D0	Ch1 D1	Ch1 D0	Ch1 D1
Word alignment: yes	2	reserved	SB2	reserved	CB2
	3	Ch2 D0	Ch2 D1	Ch2 D0	Ch2 D1

**Key**

Complete evaluation: In addition to the process data, the control and status bytes are also mapped into the address space.

Motorola format: Motorola or Intel format can be set.

Word alignment: In order for the channel address range to commence at a word boundary, empty bytes are inserted into the process image as appropriate.

SB n: Status byte for channel n (appears in the input process image).

CB n: Control byte for channel n (appears in the output process image).

Ch n D0: channel n, lower-value data byte

Ch n D1: channel n, higher-value data byte

reserved: This byte is assigned to the process data memory, although it has no function.

"-": This byte is not assigned or used by the terminal/module.

## 5.3 Control and status byte

**Channel 1****Process data mode****Control byte 1 (for process data mode)**

Control byte 1 (CB1) is located in the [output image \[► 41\]](#), and is transmitted from the controller to the terminal.

Bit	CB1.7	CB1.6	CB1.5	CB1.4	CB1.3	CB1.2	CB1.1	CB1.0
Name	RegAccess	-	-	-	-	-	CaliDisReq	StartManCali

**Key**

Bit	Name	Description
CB1.7	RegAccess	0 <sub>bin</sub> Register communication off (process data mode)
CB1.6 to CB1.2	-	0 <sub>bin</sub> reserved
CB1.1	CaliDisReq	1 <sub>bin</sub> Blocking automatic calibration
CB1.0	StartManCali	1 <sub>bin</sub> start manual calibration

**Status byte 1 (for process data mode)**

The status byte 1 (SB1) is located in the [input image \[► 41\]](#) and is transmitted from terminal to the controller.

Bit	SB1.7	SB1.6	SB1.5	SB1.4	SB1.3	SB1.2	SB1.1	SB1.0
Name	RegAccess	Error	StateThreshold2		StateThreshold1		Overload	Underload

**Key**

Bit	Name	Description
SB1.7	RegAccess	0 <sub>bin</sub> Acknowledgment for process data mode
SB1.6	Error	0 <sub>bin</sub> no error detected
		1 <sub>bin</sub> KL3142 up to firmware 2B
		KL3142 with firmware 2C or higher and R32.14 [▶ 50] = 1 <sub>bin</sub>
		KL3132, KL3152, KL3162, KL3172, KL3182 up to firmware 2A
		KL3132, KL3152, KL3162, KL3172, KL3182 with firmware 2B or higher and R32.14 [▶ 50] = 1 <sub>bin</sub>
		<ul style="list-style-type: none"> <li>• Overload (bit SB1.1 [▶ 44] is set) or</li> <li>• Underload (bit SB1.0 [▶ 44] is set)</li> </ul>
		<ul style="list-style-type: none"> <li>• The last calibration was terminated with an error (no stability)</li> </ul>
SB1.5, SB1.4	StateThreshold2	00 <sub>bin</sub> Limit value 2 [▶ 52] is not enabled via bit R32.10 [▶ 50] of the feature register
		01 <sub>bin</sub> Process data is less than limit value 2
		10 <sub>bin</sub> Process data is greater than limit value 2
		11 <sub>bin</sub> Process data equals limit value 2
SB1.3, SB1.2	StateThreshold1	00 <sub>bin</sub> Limit value 1 [▶ 52] is not enabled via bit R32.9 [▶ 50] of the feature register
		01 <sub>bin</sub> Process data is less than limit value 1
		10 <sub>bin</sub> Process data is greater than limit value 1
		11 <sub>bin</sub> Process data equals limit value 1
SB1.1	Overload	1 <sub>bin</sub> Process data is greater than specified in register R21 [▶ 50]. The red error LED of this channel is lit.
SB1.0	Underload	1 <sub>bin</sub> Process data are less than specified in register R22 [▶ 50]. The red error LED of this channel is lit.
		The calibration is active if SB1.0 and SB1.1 are set simultaneously.

**Register communication**

**Control byte 1 (in register communication)**

Control byte 1 (CB1) is located in the output image [▶ 41], and is transmitted from the controller to the terminal.

Bit	CB1.7	CB1.6	CB1.5	CB1.4	CB1.3	CB1.2	CB1.1	CB1.0
Name	RegAccess	R/W	Reg. no.					

**Key**

Bit	Name	Description
CB1.7	RegAccess	1 <sub>bin</sub> Register communication switched on
CB1.6	R/W	0 <sub>bin</sub> Read access
		1 <sub>bin</sub> Write access
CB1.5 to CB1.0	Reg. no.	Register number: Enter the number of the <u>register</u> [▶ 47] that you - want to read with input data word <u>DataIn</u> [▶ 41] or - want to write with output data word <u>DataOut</u> [▶ 41].

**Status byte 1 (in register communication)**

The status byte 1 (SB1) is located in the [input image \[► 41\]](#) and is transmitted from terminal to the controller.

Bit	SB1.7	SB1.6	SB1.5	SB1.4	SB1.3	SB1.2	SB1.1	SB1.0
Name	RegAccess	R/W	Reg. no.					

**Key**

Bit	Name	Description	
SB1.7	RegAccess	1 <sub>bin</sub>	Acknowledgment for register access
SB1.6	R	0 <sub>bin</sub>	Read access
SB1.5 to SB1.0	Reg. no.	Number of the register that was read or written.	

**Channel 2**

The control and status bytes of channel 2 (CB2 and SB2) have the same structure as the control and status bytes of [channel 1 \[► 44\]](#).

## 5.4 Register overview

The registers are used for the parameterization of the Bus Terminals and are available for each channel. They can be read or written by means of [register communication \[► 45\]](#).

Register no.	Comment	Default value	R/W	Memory	
R0 [► 48]	Raw ADC value	0x0000	0 <sub>dec</sub>	R RAM	
R1 [► 48]	Calibration value: Offset	typically 0x0046	typically 70 <sub>dec</sub>	R RAM	
R2 [► 48]	Calibration value: Gain	typically 0xF1CC	typically 61900 <sub>dec</sub>	R RAM	
R3	reserved	-	-	-	
R4	reserved	-	-	-	
R5	reserved	-	-	-	
R6 [► 48]	Diagnostic register	0x0000	0 <sub>dec</sub>	R RAM	
R7 [► 48]	Command register	0x0000	0 <sub>dec</sub>	R/W RAM	
R8 [► 49]	Terminal type	KL3132:	0xC3C	3132 <sub>dec</sub>	R ROM
		KL3142:	0xC46	3142 <sub>dec</sub>	
		KL3152:	0xC50	3152 <sub>dec</sub>	
		KL3162:	0xC5A	3162 <sub>dec</sub>	
		KL3172:	0x0C64	3172 <sub>dec</sub>	
		KL3182:	0x0C6E	3182 <sub>dec</sub>	
R9 [► 49]	Firmware version	e.g. 0x3141	e.g. 12609 <sub>dec</sub>	R ROM	
R10	Multiplex shift register	0x0218 / 0x0130	536 <sub>dec</sub> / 304 <sub>dec</sub>	R ROM	
R11	Signal channels	0x0218	536 <sub>dec</sub>	R ROM	
R12 [► 49]	minimum data length of a channel	0x0098	152 <sub>dec</sub>	R ROM	
R13	Data structure	0x0007	7 <sub>dec</sub>	R ROM	
R14	reserved	-	-	-	
R15	Alignment register	typically 0x7F80	typically 32,640 <sub>dec</sub>	R/W RAM	
R16 [► 49]	Hardware version number	e.g. 0x0000	e.g. 0 <sub>dec</sub>	R/W SEEPROM	
R17 [► 49]	Vendor calibration: Offset	typically 0x0046	70 <sub>dec</sub>	R/W SEEPROM	
R18 [► 49]	Vendor calibration: Gain	typically 0x5208	typically 21000 <sub>dec</sub>	R/W SEEPROM	
R19 [► 50]	Manufacturer scaling: Offset	0x0000	0 <sub>dec</sub>	R/W SEEPROM	
R20 [► 50]	Manufacturer scaling: Gain	KL3162, KL3172, KL3142, KL3152:	0x0100	256 <sub>dec</sub>	R/W SEEPROM
		KL3132, KL3182:	0x0080	128 <sub>dec</sub>	
R21 [► 50]	Upper limitation of the measuring range	KL3162, KL3172, KL3142, KL3152:	0xFFFF	65535 <sub>dec</sub>	R/W SEEPROM
		KL3132, KL3182:	0x7FFF	+32767 <sub>dec</sub>	
R22 [► 50]	Lower limitation of the measuring range	KL3162, KL3172, KL3142, KL3152:	0x0000	0 <sub>dec</sub>	R/W SEEPROM
		KL3132, KL3182:	0x8000	-32768 <sub>dec</sub>	
R23 [► 50]	Reference calibration value: Offset	typically 0x0046	typically 70 <sub>dec</sub>	R/W SEEPROM	
R24 [► 50]	Reference calibration value: Gain	typically 0xF1CC	typically 61900 <sub>dec</sub>	R/W SEEPROM	
R25	reserved	-	-	-	
...	reserved	-	-	-	
R28	reserved	-	-	-	
R29	Terminal type, special identification	KL3132-0000	0x0000	0 <sub>dec</sub>	R ROM
		KL3142-0000	0x0000	0 <sub>dec</sub>	
		KL3152-0000	0x0000	0 <sub>dec</sub>	
		KL3162-0000	0x0000	0 <sub>dec</sub>	
		KL3172-0000	0x0000	0 <sub>dec</sub>	
		KL3172-0500	0x01F4	500 <sub>dec</sub>	
		KL3172-1000	0x03E8	1000 <sub>dec</sub>	
KL3182-0000	0x0000	0 <sub>dec</sub>			
R30	reserved	-	-	-	
R31 [► 50]	Code word register	0x0000	0 <sub>dec</sub>	R/W RAM	
R32 [► 50]	Feature register	KL3162, KL3172, KL3142, KL3152:	0x0180	384 <sub>dec</sub>	R/W SEEPROM
		KL3132, KL3182:	0x0182	386 <sub>dec</sub>	

Register no.	Comment	Default value		R/W	Memory
R33 [ <a href="#">▶ 52</a> ]	User offset	0x0000	0 <sub>dec</sub>	R/W	SEEPROM
R34 [ <a href="#">▶ 52</a> ]	User gain	0x0100	256 <sub>dec</sub>	R/W	SEEPROM
R35 [ <a href="#">▶ 52</a> ]	Limit value 1	0x0000	0 <sub>dec</sub>	R/W	SEEPROM
R36 [ <a href="#">▶ 52</a> ]	Limit value 2	0x0000	0 <sub>dec</sub>	R/W	SEEPROM
R37 [ <a href="#">▶ 52</a> ]	Filter constants of the A/D converter, and configuration bits for the filter	0x35C0	13760 <sub>dec</sub>	R/W	SEEPROM
R38	reserved	-	-	-	-
R39	reserved	-	-	-	-
R40 [ <a href="#">▶ 53</a> ]	Calibration interval *)	0x0708	1800 <sub>dec</sub>	R/W	SEEPROM
R41	reserved	-	-	-	-
...	reserved	-	-	-	-
R43	reserved	-	-	-	-
R44 [ <a href="#">▶ 53</a> ]	Interval for forced calibration **)	0x0003	3 <sub>dec</sub>	R/W	SEEPROM
R45	reserved	-	-	-	-
R46	reserved	-	-	-	-
R47 [ <a href="#">▶ 53</a> ]	Number of stable measured values	0x0032	50 <sub>dec</sub>	R/W	SEEPROM
R48 [ <a href="#">▶ 53</a> ]	Tolerance for measured value stability	0x0005	5 <sub>dec</sub>	R/W	SEEPROM
R49	reserved	-	-	-	-
...	reserved	-	-	-	-
R63	reserved	-	-	-	-

\*) In multiples of 100 ms

\*\*\*) In multiples of register [R40 \[▶ 53\]](#)

## 5.5 Register description

The registers are used for the parameterization of the Bus Terminals and are available for each channel. They can be read or written by means of [register communication \[▶ 45\]](#).

### R0: Raw ADC value

Register R0 contains the raw value of the analog/digital converter. This is the unchanged analog value prior to any scaling.

### R1: Calibration value - offset

After a calibration, the offset value that was determined is entered in register R1 and used for the correction calculation.

### R2: Calibration value - gain

After a calibration, the gain value that was determined is entered in register R2 and used for the correction calculation.

### R6: Diagnostic register

Status byte [SB1 \[▶ 44\]](#) is placed into register R6.

### R7: Command register



#### User code word

For the following commands to be executed, it is first necessary for the user code word, 0x1235, to be entered into [register R31 \[▶ 50\]](#).



**Command 0x7000: Restore Factory Settings**

Entering 0x7000 in register R7 restores the factory settings for the following registers of both channels:

**KL3162, KL3172, KL3142, KL3152:**

R32: 0x0180 (384<sub>dec</sub>)  
 R33: 0x0000 (0<sub>dec</sub>)  
 R34: 0x0100 (256<sub>dec</sub>)  
 R35: 0x0000 (0<sub>dec</sub>)  
 R36: 0x0000 (0<sub>dec</sub>)  
 R37: 0x35C0 (13760<sub>dec</sub>)  
 R40: 0x0708 (1800<sub>dec</sub>)  
 R44: 0x0003 (3<sub>dec</sub>)  
 R47: 0x0032 (50<sub>dec</sub>)  
 R48: 0x0005 (5<sub>dec</sub>)

**KL3132, KL3182:**

R32: 0x0182 (386<sub>dec</sub>)  
 R33: 0x0000 (0<sub>dec</sub>)  
 R34: 0x0100 (256<sub>dec</sub>)  
 R35: 0x0000 (0<sub>dec</sub>)  
 R36: 0x0000 (0<sub>dec</sub>)  
 R37: 0x35C0 (13760<sub>dec</sub>)  
 R40: 0x0708 (1800<sub>dec</sub>)  
 R44: 0x0003 (3<sub>dec</sub>)  
 R47: 0x0032 (50<sub>dec</sub>)  
 R48: 0x0005 (5<sub>dec</sub>)

---

**● Restore Factory Settings**

The Restore Factory Settings command simultaneously resets **both** terminal channels to the delivery state, irrespective from which register it is called.

---

**R8: Terminal description**

The description of the terminal is contained in register R8.

KL3172: 0x0C64 (3172<sub>dec</sub>)  
 KL3182: 0x0C6E (3182<sub>dec</sub>)  
 KL3132: 0xC3C (3132<sub>dec</sub>)  
 KL3162: 0xC5A (3162<sub>dec</sub>)  
 KL3142: 0xC46 (3142<sub>dec</sub>)  
 KL3152: 0xC50 (3152<sub>dec</sub>)

**R9: Firmware version**

Register R9 contains the ASCII coding of the terminal's firmware version, e.g. **0x3141 = '1A'**. The **'0x31'** corresponds here to the ASCII character **'1'**, while the **'0x41'** represents the ASCII character **'A'**. This value can not be changed.

**R12: Minimum data length of a channel**

Bits 0 to 6 of the high-order byte specify the minimum number of output data in bits:  $000.0000_{bin} = 0_{dec}$ , so 0 bytes.

Bits 0 to 6 of the low-order byte specify the minimum number of input data in bits:  $001.1000_{bin} = 24_{dec}$ , hence 3 bytes.

The fact that bit 7 is set indicates that the control and status byte are not mandatory for the terminal function and are not transferred in compact mode.

**R16: Hardware version number**

Register R16 contains the hardware version of the terminal.

**R17: Vendor calibration - offset**

This register contains the vendor calibration offset (16 bit signed integer).

**R18: Vendor calibration - gain**

This register contains the vendor calibration gain (16 bit unsigned integer  $\times 2^{-16} + 1$ ). Examples:

0x0000 means factor 1

0xFFFF means factor 2

**R19: Manufacturer scaling - offset:**

This register contains the offset of the manufacturer scaling. Can be activated via [R32.1 \[► 50\]](#) in the feature register (16 bit signed integer).

**R20: Manufacturer scaling - gain:**

This register contains the gain of the manufacturer scaling. Can be activated via [R32.1 \[► 50\]](#) in the feature register (16 bit unsigned integer  $\times 2^{-8} + 1$ ). Examples:  
0x0100 means factor 1.  
0x0080 means factor 0.5

**R21: Upper measuring range limit**

This register contains the upper measuring range limit. It can be activated by [R32.8 \[► 50\]](#) in the feature register.

**R22: Lower measuring range limit**

This register contains the lower measuring range limit. It can be activated by [R32.8 \[► 50\]](#) in the feature register.

**R23: Reference calibration value: Offset**

This register contains the reference value of the calibration, which is determined during the vendor calibration.

**R24: Reference calibration value: Gain**

This register contains the reference value of the calibration, which is determined during the vendor calibration.

**R31: Code word register**

- If you write values into the user registers without first entering the user code word (0x1235) into the code word register, the terminal will not accept the supplied data.
- If you write values into the user registers and have previously entered the user code word (0x1235) in the code word register, these values are stored in the RAM registers and in the SEEPROM registers and are therefore retained if the terminal is restarted.

The code word is reset if the terminal is restarted.

**R32: Feature register**

The feature register specifies the terminal's configuration.

Bit	R32.15	R32.14	R32.13	R32.12	R32.11	R32.10	R32.9	R32.8
Name	Calibration Display	Display StabilityError	-	-	disChannel	enTh2	enTh1	enOverProt

Bit	R32.7	R32.6	R32.5	R32.4	R32.3	R32.2	R32.1	R32.0
Name	enStable	disDiff Measure	disCali	enSiemens Format	enAverage Format	disWd Timer	enManScal	enUsrScal

Key

Bit	Name	Description	default
R32.15*	CallibrationDisplay	0 <sub>bin</sub> During the calibration, the terminal sets the overload bit <u>SB1.1</u> [▶ 44] and the underload bit <u>SB1.0</u> [▶ 44].	0 <sub>bin</sub>
		1 <sub>bin</sub> Compatibility mode: During calibration, the terminal sets the error bit <u>SB1.6</u> [▶ 44].	
R32.14*	Display StabilityError	0 <sub>bin</sub> Stability error is not displayed.	0 <sub>bin</sub>
		1 <sub>bin</sub> If no <u>stabilization</u> [▶ 16] of the calibration values is achieved, the terminal indicates this by setting the error bit <u>SB1.6</u> [▶ 44]. (see note below)	

**i** Fluctuating measuring signals

Strongly fluctuating measuring signals can make stabilization of the calibration values impossible. In this case, skip the stabilization and disable it with bit R32.7.

Bit	Name	Description	default
R32.13	-	reserved	0 <sub>bin</sub>
R32.12	-	reserved	0 <sub>bin</sub>
R32.11	disChannel	0 <sub>bin</sub> Channel switched on	0 <sub>bin</sub>
		1 <sub>bin</sub> Channel switched off	
R32.10	enTh2	0 <sub>bin</sub> Limit value 2 is not active	0 <sub>bin</sub>
		1 <sub>bin</sub> Limit value 2 is active	
R32.9	enTh1	0 <sub>bin</sub> Limit value 1 is not active	0 <sub>bin</sub>
		1 <sub>bin</sub> Limit value 1 is active	
R32.8	enOverProt	0 <sub>bin</sub> Measuring range limitation not active	1 <sub>bin</sub>
		1 <sub>bin</sub> Measuring range limitation active	
R32.7	enStable	0 <sub>bin</sub> <u>Stabilization</u> [▶ 16] of the calibration value not active	1 <sub>bin</sub>
		1 <sub>bin</sub> <u>Stabilization</u> [▶ 16] of the calibration value active	
R32.6	disDiffMeasure	0 <sub>bin</sub> Differential measurement active	0 <sub>bin</sub>
		1 <sub>bin</sub> Differential measurement not active (only KL3132, KL3162, KL3172, KL3182)	
R32.5	disCali	0 <sub>bin</sub> Cyclic calibration of the A/D converter active	0 <sub>bin</sub>
		1 <sub>bin</sub> Cyclic calibration of the A/D converter not active	
R32.4	enSiemensFormat	0 <sub>bin</sub> Siemens output format not active	0 <sub>bin</sub>
		1 <sub>bin</sub> Siemens output format active	
R32.3	enAverageFormat	0 <sub>bin</sub> Signed amount representation not active	0 <sub>bin</sub>
		1 <sub>bin</sub> Signed amount representation active	
R32.2	disWdTimer	0 <sub>bin</sub> Watchdog timer is active (the watchdog is triggered if no process data are received for 100 ms)	0 <sub>bin</sub>
		1 <sub>bin</sub> Watchdog timer is not active	
R32.1	enManScal	0 <sub>bin</sub> Manufacturer scaling is not active	0 <sub>bin</sub> KL3162, KL3172, KL3142, KL3152:
		1 <sub>bin</sub> Manufacturer scaling is active	
R32.0	enUsrScal	0 <sub>bin</sub> User scaling is not active	0 <sub>bin</sub>
		1 <sub>bin</sub> User scaling is active	

\*) Bit R32.14 and bit R32.15 are only available with the following firmware versions:

- KL3132, KL3152, KL3162, KL3172, KL3182: Firmware version 2B or higher
- KL3142: Firmware version 2C or higher

For lower firmware versions, bits R32.14 and R32.15 are not evaluated.

These terminals always set the error bit [SB1.6](#) [[▶ 44](#)] during the calibration and cannot indicate the stability error!

### R33: User scaling - offset

This register contains the offset of the user scaling. The user scaling can be activated in the feature register through bit [R32.0](#) [[▶ 50](#)] (16 bit signed integer).

### R34: User scaling - gain

This register contains the gain of the user scaling. The user scaling can be activated in the feature register through bit [R32.0](#) [[▶ 50](#)] (16 bit unsigned integer  $\times 2^{-8} + 1$ .  $1_{\text{dec}}$  corresponds to  $0x0100$ ).

### R35: Limit value 1

Limit value 1 is entered in register R35. The limit value can be activated in the feature register through bit [R32.9](#) [[▶ 50](#)].

### R36: Limit value 2

Limit value 2 is entered in register R36. The limit value can be activated in the feature register through bit [R32.10](#) [[▶ 50](#)].

### R37: Filter constants of the A/D converter, and configuration bits for the filter

(default value:  $35C0_{\text{hex}}$ )

The terminal has two low-pass filter stages:

- The first stage consists of a  $\text{sinc}^3$  filter, and is always active.
- The second stage consists of a 22nd order FIR filter. This can be deactivated.

Bit	15	14	13	12	11	10	9	8	7	6	5	4	3	2	1	0
Name	Filter constants SF (SF.11 to SF.0)												Zero	Zero	SkipFIR	Fast

#### Key

Bit	Name	Description	Default
R37.15	Filter constant SF (SF.11 - SF.0)	The filter constant $SF$ specifies the 3dB limit frequency of the $\text{sinc}^3$ filter. The value ranges from 150 to 2047. The 3 dB limit frequency $F_{\text{Limit}}$ and the 64.5 dB stop frequency $F_{\text{Stop}}$ are calculated as follows: (see following table)	$35C_{\text{hex}}$ ( $860_{\text{dec}}$ )
...			
R37.4			

Skip = 0

$$F_{\text{Limit}} = 11981 / SF$$

$$F_{\text{Stop}} = 43008 / SF$$

Skip = 1

$$F_{\text{Limit}} = 80486 / SF$$

Bit	Name	Description	Default
R37.3	Zero	$0_{\text{bin}}$ See note below	$0_{\text{bin}}$
R37.2	Zero	$0_{\text{bin}}$	$0_{\text{bin}}$

#### **i** Do not change

Bits R37.2 and R37.3 must always be ZERO, otherwise errors will occur in the A/D converter!

Bit	Name	Description	Default
R37.1	SkipFIR	0 <sub>bin</sub>	FIR filter is active.
		1 <sub>bin</sub>	FIR filter is bypassed.
R37.0	Fast	0 <sub>bin</sub>	Fast Step Mode is not active.
		1 <sub>bin</sub>	Fast Step Mode is active: a fast reaction will follow jumps at the input, in spite of the filter stage being active. In this case the filter is bypassed!

**Examples**

Value in R37	F <sub>Stop</sub>	Cycle time
0x35C0	50 Hz	140 ms
0x2660	70 Hz	100 ms
0x1330	140 Hz	50 ms
0x7FF1		40 ms
0x3FF1		20 ms
0x1001		<4 ms
Value in R37	F <sub>Limit</sub>	Cycle time
0x7FF2	39.6 Hz	40 ms
0x3FF2	77.36 Hz	20 ms
0x1002	158 Hz	<4 ms

**R40: Calibration interval**

This register contains the calibration interval for the terminal's automatic calibration. The unit is 100 ms. The automatic calibration can be activated through bit [R32.5 \[► 50\]](#) in the feature register.

**R44: Forced calibration interval**

This register contains the interval for the terminal's forced calibration. This interval is always a multiple (the default is 3<sub>dec</sub>) of the calibration interval. ([R40 \[► 53\]](#)). The interval for forced calibration when the terminal leaves the factory is therefore 3 x 180 s = 540 s. The forced calibration can be activated through bit [R32.5 \[► 50\]](#) in the feature register.

**R47: Number of stable measured values**

This register contains the number of stable measured values recorded during the calibration.

**R48: Tolerance for measured value stability**

This register contains the specified stable measured value tolerance.

## 5.6 Examples of Register Communication

The numbering of the bytes in the examples corresponds to the display without word alignment.

### 5.6.1 Example 1: Reading the firmware version from register 9

#### Output Data

Byte 0: Control byte	Byte 1: DataOUT1, high byte	Byte 2: DataOUT1, low byte
0x89 (1000 1001 <sub>bin</sub> )	0xXX	0xXX

Explanation:

- Bit 0.7 set means: Register communication switched on.
- Bit 0.6 not set means: reading the register.
- Bits 0.5 to 0.0 specify the register number 9 with 00 1001<sub>bin</sub>.
- The output data word (byte 1 and byte 2) has no meaning during read access. To change a register, write the required value into the output word.

#### Input Data (answer of the Bus Terminal)

Byte 0: Status byte	Byte 1: DataIN1, high byte	Byte 2: DataIN1, low byte
0x89	0x33	0x41

Explanation:

- The terminal returns the value of the control byte as a receipt in the status byte.
- The terminal returns the firmware version 0x3341 in the input data word (byte 1 and byte 2). This is to be interpreted as an ASCII code:
  - ASCII code 0x33 represents the digit 3
  - ASCII code 0x41 represents the letter A
 The firmware version is thus 3A.

### 5.6.2 Example 2: Writing to a user register



#### Code word

In normal mode all user registers are read-only with the exception of Register 31. In order to deactivate this write protection you must write the code word (0x1235) into Register 31. If a value other than 0x1235 is written into Register 31, write protection is reactivated. Please note that changes to a register only become effective after restarting the terminal (power-off/power-on).

#### I. Write the code word (0x1235) into register 31.

#### Output Data

Byte 0: Control byte	Byte 1: DataOUT1, high byte	Byte 2: DataOUT1, low byte
0xDF (1101 1111 <sub>bin</sub> )	0x12	0x35

Explanation:

- Bit 0.7 set means: Register communication switched on.
- Bit 0.6 set means: writing to the register.
- Bits 0.5 to 0.0 specify the register number 31 with 01 1111<sub>bin</sub>.

- The output data word (byte 1 and byte 2) contains the code word (0x1235) for deactivating write protection.

**Input Data (answer of the Bus Terminal)**

Byte 0: Status byte	Byte 1: DataIN1, high byte	Byte 2: DataIN1, low byte
0x9F (1001 1111 <sub>bin</sub> )	0xXX	0xXX

Explanation:

- The terminal returns a value as a receipt in the status byte that differs only in bit 0.6 from the value of the control byte.
- The input data word (byte 1 and byte 2) is of no importance after the write access. Any values still displayed are invalid!

**II. Read Register 31 (check the set code word)**

**Output Data**

Byte 0: Control byte	Byte 1: DataOUT1, high byte	Byte 2: DataOUT1, low byte
0x9F (1001 1111 <sub>bin</sub> )	0xXX	0xXX

Explanation:

- Bit 0.7 set means: Register communication switched on.
- Bit 0.6 not set means: reading the register.
- Bits 0.5 to 0.0 specify the register number 31 with 01 1111<sub>bin</sub>.
- The output data word (byte 1 and byte 2) has no meaning during read access.

**Input Data (answer of the Bus Terminal)**

Byte 0: Status byte	Byte 1: DataIN1, high byte	Byte 2: DataIN1, low byte
0x9F (1001 1111 <sub>bin</sub> )	0x12	0x35

Explanation:

- The terminal returns the value of the control byte as a receipt in the status byte.
- The terminal returns the current value of the code word register in the input data word (byte 1 and byte 2).

**III. Write to Register 32 (change contents of the feature register)**

**Output data**

Byte 0: Control byte	Byte 1: DataIN1, high byte	Byte 2: DataIN1, low byte
0xE0 (1110 0000 <sub>bin</sub> )	0x00	0x02

Explanation:

- Bit 0.7 set means: Register communication switched on.
- Bit 0.6 set means: writing to the register.
- Bits 0.5 to 0.0 indicate register number 32 with 10 0000<sub>bin</sub>.
- The output data word (byte 1 and byte 2) contains the new value for the feature register.

**⚠ CAUTION****Observe the register description!**

The value of 0x0002 given here is just an example!

The bits of the feature register change the properties of the terminal and have a different meaning, depending on the type of terminal. Refer to the description of the feature register of your terminal (chapter *Register description*) regarding the meaning of the individual bits before changing the values.

**Input data (response from the Bus Terminal)**

Byte 0: Status byte	Byte 1: DataIN1, high byte	Byte 2: DataIN1, low byte
0xA0 (1010 0000 <sub>bin</sub> )	0xXX	0xXX

Explanation:

- The terminal returns a value as a receipt in the status byte that differs only in bit 0.6 from the value of the control byte.
- The input data word (byte 1 and byte 2) is of no importance after the write access. Any values still displayed are invalid!

**IV. Read register 32 (check changed feature register)****Output Data**

Byte 0: Control byte	Byte 1: DataOUT1, high byte	Byte 2: DataOUT1, low byte
0xA0 (1010 0000 <sub>bin</sub> )	0xXX	0xXX

Explanation:

- Bit 0.7 set means: Register communication switched on.
- Bit 0.6 not set means: reading the register.
- Bits 0.5 to 0.0 indicate register number 32 with 10 0000<sub>bin</sub>.
- The output data word (byte 1 and byte 2) has no meaning during read access.

**Input Data (answer of the Bus Terminal)**

Byte 0: Status byte	Byte 1: DataIN1, high byte	Byte 2: DataIN1, low byte
0xA0 (1010 0000 <sub>bin</sub> )	0x00	0x02

Explanation:

- The terminal returns the value of the control byte as a receipt in the status byte.
- The terminal returns the current value of the feature register in the input data word (byte 1 and byte 2).

**V. Write register 31 (reset code word)****Output Data**

Byte 0: Control byte	Byte 1: DataOUT1, high byte	Byte 2: DataOUT1, low byte
0xDF (1101 1111 <sub>bin</sub> )	0x00	0x00

Explanation:

- Bit 0.7 set means: Register communication switched on.
- Bit 0.6 set means: writing to the register.
- Bits 0.5 to 0.0 specify the register number 31 with 01 1111<sub>bin</sub>.
- The output data word (byte 1 and byte 2) contains 0x0000 for reactivating write protection.



**Input Data (answer of the Bus Terminal)**

Byte 0: Status byte	Byte 1: DataIN1, high byte	Byte 2: DataIN1, low byte
0x9F (1001 1111 <sub>bin</sub> )	0xXX	0xXX

Explanation:

- The terminal returns a value as a receipt in the status byte that differs only in bit 0.6 from the value of the control byte.
- The input data word (byte 1 and byte 2) is of no importance after the write access. Any values still displayed are invalid!

## 6 Appendix

### 6.1 Beckhoff Identification Code (BIC)

The Beckhoff Identification Code (BIC) is increasingly being applied to Beckhoff products to uniquely identify the product. The BIC is represented as a Data Matrix Code (DMC, code scheme ECC200), the content is based on the ANSI standard MH10.8.2-2016.

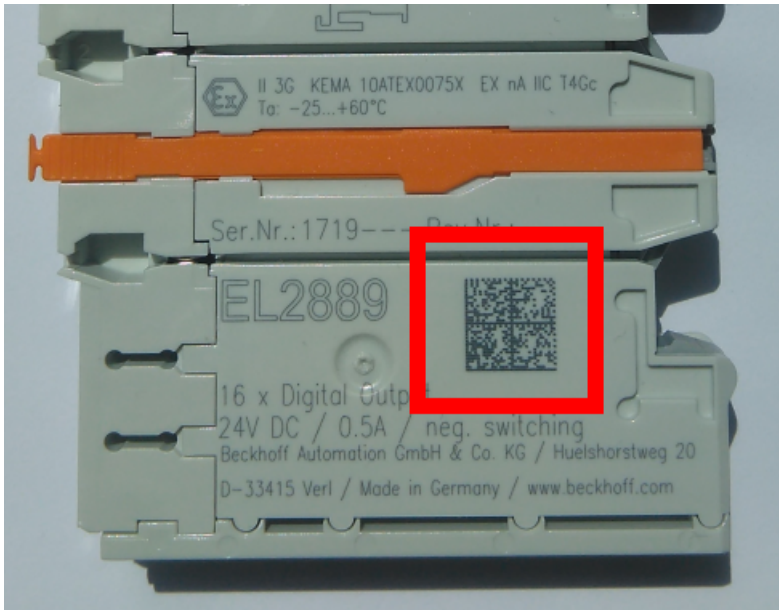

Fig. 24: BIC as data matrix code (DMC, code scheme ECC200)

The BIC will be introduced step by step across all product groups.

Depending on the product, it can be found in the following places:

- on the packaging unit
- directly on the product (if space suffices)
- on the packaging unit and the product

The BIC is machine-readable and contains information that can also be used by the customer for handling and product management.

Each piece of information can be uniquely identified using the so-called data identifier (ANSI MH10.8.2-2016). The data identifier is followed by a character string. Both together have a maximum length according to the table below. If the information is shorter, spaces are added to it.

Following information is possible, positions 1 to 4 are always present, the other according to need of production:

Position	Type of information	Explanation	Data identifier	Number of digits incl. data identifier	Example
1	Beckhoff order number	<b>Beckhoff order number</b>	1P	8	<b>1P</b> 072222
2	Beckhoff Traceability Number (BTN)	<b>Unique serial number, see note below</b>	SBTN	12	<b>S</b> BTNk4p562d7
3	Article description	<b>Beckhoff article description, e.g. EL1008</b>	1K	32	<b>1K</b> EL1809
4	Quantity	<b>Quantity in packaging unit, e.g. 1, 10, etc.</b>	Q	6	<b>Q</b> 1
5	Batch number	Optional: Year and week of production	2P	14	<b>2P</b> 401503180016
6	ID/serial number	Optional: Present-day serial number system, e.g. with safety products	51S	12	<b>51S</b> 678294
7	Variant number	Optional: Product variant number on the basis of standard products	30P	32	<b>30P</b> F971, 2*K183
...					

Further types of information and data identifiers are used by Beckhoff and serve internal processes.

**Structure of the BIC**

Example of composite information from positions 1 to 4 and with the above given example value on position 6. The data identifiers are highlighted in bold font:

**1P**072222**S**BTNk4p562d7**1K**EL1809 **Q**1 **51S**678294

Accordingly as DMC:



Fig. 25: Example DMC **1P**072222**S**BTNk4p562d7**1K**EL1809 **Q**1 **51S**678294

**BTN**

An important component of the BIC is the Beckhoff Traceability Number (BTN, position 2). The BTN is a unique serial number consisting of eight characters that will replace all other serial number systems at Beckhoff in the long term (e.g. batch designations on IO components, previous serial number range for safety products, etc.). The BTN will also be introduced step by step, so it may happen that the BTN is not yet coded in the BIC.

**NOTE**

This information has been carefully prepared. However, the procedure described is constantly being further developed. We reserve the right to revise and change procedures and documentation at any time and without prior notice. No claims for changes can be made from the information, illustrations and descriptions in this information.

## 6.2 Support and Service

Beckhoff and their partners around the world offer comprehensive support and service, making available fast and competent assistance with all questions related to Beckhoff products and system solutions.

### Beckhoff's branch offices and representatives

Please contact your Beckhoff branch office or representative for local support and service on Beckhoff products!

The addresses of Beckhoff's branch offices and representatives round the world can be found on her internet pages: <https://www.beckhoff.com>

You will also find further documentation for Beckhoff components there.

### Beckhoff Support

Support offers you comprehensive technical assistance, helping you not only with the application of individual Beckhoff products, but also with other, wide-ranging services:

- support
- design, programming and commissioning of complex automation systems
- and extensive training program for Beckhoff system components

Hotline: +49 5246 963 157  
Fax: +49 5246 963 9157  
e-mail: [support@beckhoff.com](mailto:support@beckhoff.com)

### Beckhoff Service

The Beckhoff Service Center supports you in all matters of after-sales service:

- on-site service
- repair service
- spare parts service
- hotline service

Hotline: +49 5246 963 460  
Fax: +49 5246 963 479  
e-mail: [service@beckhoff.com](mailto:service@beckhoff.com)

### Beckhoff Headquarters

Beckhoff Automation GmbH & Co. KG

Huelshorstweg 20  
33415 Verl  
Germany

Phone: +49 5246 963 0  
Fax: +49 5246 963 198  
e-mail: [info@beckhoff.com](mailto:info@beckhoff.com)  
web: <https://www.beckhoff.com>

## Table of figures

Fig. 1	KL3132.....	9
Fig. 2	KL3142.....	11
Fig. 3	LEDs .....	13
Fig. 4	Differential measuring .....	17
Fig. 5	Spring contacts of the Beckhoff I/O components .....	18
Fig. 6	Attaching on mounting rail.....	19
Fig. 7	Disassembling of terminal .....	20
Fig. 8	Power contact on left side .....	21
Fig. 9	Standard wiring .....	22
Fig. 10	Pluggable wiring.....	22
Fig. 11	High Density Terminals .....	23
Fig. 12	Connecting a cable on a terminal point.....	24
Fig. 13	KL3132 - Contact assignment.....	26
Fig. 14	KL3142 - Contact assignment.....	26
Fig. 15	KL3172-0000 - application example.....	30
Fig. 16	KS2000 configuration software .....	31
Fig. 17	Display of the fieldbus station in KS2000.....	33
Fig. 18	KS2000 branch for channel 1 of the KL3172 .....	34
Fig. 19	Register view in KS2000 .....	35
Fig. 20	Settings via KS2000.....	36
Fig. 21	Settings of KL3314 via visualization of TwinCAT 3.....	39
Fig. 22	Opening the *. tzip archive .....	39
Fig. 23	Search of the existing HW configuration for the EtherCAT configuration of the example.....	40
Fig. 24	BIC as data matrix code (DMC, code scheme ECC200) .....	58
Fig. 25	Example DMC 1P072222SBTNk4p562d71KEL1809 Q1 51S678294 .....	59



More Information:  
[www.beckhoff.com/KL3xxx](http://www.beckhoff.com/KL3xxx)

Beckhoff Automation GmbH & Co. KG  
Hülshorstweg 20  
33415 Verl  
Germany  
Phone: +49 5246 9630  
[info@beckhoff.com](mailto:info@beckhoff.com)  
[www.beckhoff.com](http://www.beckhoff.com)

