

Documentation | EN

KL5121/KS5121

Incremental encoder interface with programmable outputs for a linear path control



Table of content

1 Foreword	5
1.1 Notes on the documentation	5
1.2 Safety instructions	6
1.3 Documentation Issue Status	7
2 Product overview	8
2.1 Introduction	8
2.2 Technical data	9
2.3 Basic Function Principles	10
3 Mounting and wiring	11
3.1 Instructions for ESD protection	11
3.2 Installation on mounting rails	12
3.3 Installation instructions for enhanced mechanical load capacity	15
3.4 Disposal	15
3.5 Connection	16
3.5.1 Connection system.....	16
3.5.2 Wiring.....	18
3.5.3 Shielding	19
3.6 Contact assignment and LEDs.....	20
3.7 ATEX - Special conditions (standard temperature range).....	22
3.8 Continuative documentation for ATEX and IECEx	23
4 Configuration Software KS2000	24
4.1 KS2000 - Introduction	24
5 Access from the user program	26
5.1 KL5121 –Terminal configuration	26
5.2 Mapping in the Bus Coupler	28
5.2.1 Standard format	28
5.3 Register overview.....	30
5.4 Register description	31
5.5 Control and status byte	34
5.5.1 Process data exchange.....	34
5.5.2 Register communication.....	36
5.6 Examples of Register Communication	38
5.6.1 Example 1: Reading the firmware version from register 9	38
5.6.2 Example 2: Writing to an user register	39
6 Appendix	42
6.1 Beckhoff Identification Code (BIC)	42
6.2 Support and Service.....	44

1 Foreword

1.1 Notes on the documentation

Intended audience

This description is only intended for the use of trained specialists in control and automation engineering who are familiar with the applicable national standards.

It is essential that the documentation and the following notes and explanations are followed when installing and commissioning these components.

It is the duty of the technical personnel to use the documentation published at the respective time of each installation and commissioning.

The responsible staff must ensure that the application or use of the products described satisfy all the requirements for safety, including all the relevant laws, regulations, guidelines and standards.

Disclaimer

The documentation has been prepared with care. The products described are, however, constantly under development.

We reserve the right to revise and change the documentation at any time and without prior announcement.

No claims for the modification of products that have already been supplied may be made on the basis of the data, diagrams and descriptions in this documentation.

Trademarks

Beckhoff®, TwinCAT®, TwinCAT/BSD®, TC/BSD®, EtherCAT®, EtherCAT G®, EtherCAT G10®, EtherCAT P®, Safety over EtherCAT®, TwinSAFE®, XFC®, XTS® and XPlanar® are registered trademarks of and licensed by Beckhoff Automation GmbH. Other designations used in this publication may be trademarks whose use by third parties for their own purposes could violate the rights of the owners.

Patent Pending

The EtherCAT Technology is covered, including but not limited to the following patent applications and patents: EP1590927, EP1789857, EP1456722, EP2137893, DE102015105702 with corresponding applications or registrations in various other countries.



EtherCAT® is registered trademark and patented technology, licensed by Beckhoff Automation GmbH, Germany.

Copyright

© Beckhoff Automation GmbH & Co. KG, Germany.

The reproduction, distribution and utilization of this document as well as the communication of its contents to others without express authorization are prohibited.

Offenders will be held liable for the payment of damages. All rights reserved in the event of the grant of a patent, utility model or design.

1.2 Safety instructions

Safety regulations

Please note the following safety instructions and explanations!
Product-specific safety instructions can be found on following pages or in the areas mounting, wiring, commissioning etc.

Exclusion of liability

All the components are supplied in particular hardware and software configurations appropriate for the application. Modifications to hardware or software configurations other than those described in the documentation are not permitted, and nullify the liability of Beckhoff Automation GmbH & Co. KG.

Personnel qualification

This description is only intended for trained specialists in control, automation and drive engineering who are familiar with the applicable national standards.

Description of instructions

In this documentation the following instructions are used.
These instructions must be read carefully and followed without fail!

DANGER

Serious risk of injury!

Failure to follow this safety instruction directly endangers the life and health of persons.

WARNING

Risk of injury!

Failure to follow this safety instruction endangers the life and health of persons.

CAUTION

Personal injuries!

Failure to follow this safety instruction can lead to injuries to persons.

NOTE

Damage to environment/equipment or data loss

Failure to follow this instruction can lead to environmental damage, equipment damage or data loss.



Tip or pointer

This symbol indicates information that contributes to better understanding.

1.3 Documentation Issue Status

Version	Comment
3.2.0	<ul style="list-style-type: none"> • Chapter “Technical data” updated • Document structure updated • Chapter “Disposal” added • New title page • Revision status updated
3.1.0	<ul style="list-style-type: none"> • Chapter “Instructions for ESD protection” updated • Chapter “Beckhoff Identification Code (BIC)” added
3.0.0	<ul style="list-style-type: none"> • Migration • Document structure updated

Firmware (FF) and hardware (HH) versions

Documentation, Version	KL5121, KS5121	
	FF	HH
3.2.0	3D	04
3.0.0	3D	03

The firmware and hardware versions (delivery state) of the terminal can be found in the serial number printed on the side.

Syntax of the serial number

Structure of the serial number: WW YY FF HH

- WW - week of production (calendar week)
- YY - year of production
- FF - firmware version
- HH - hardware version

Example with serial number 35 04 1B 01:

- 35 - week of production 35
- 04 - year of production 2004
- 1B - firmware version 1B
- 01 - hardware version 01

2 Product overview

2.1 Introduction

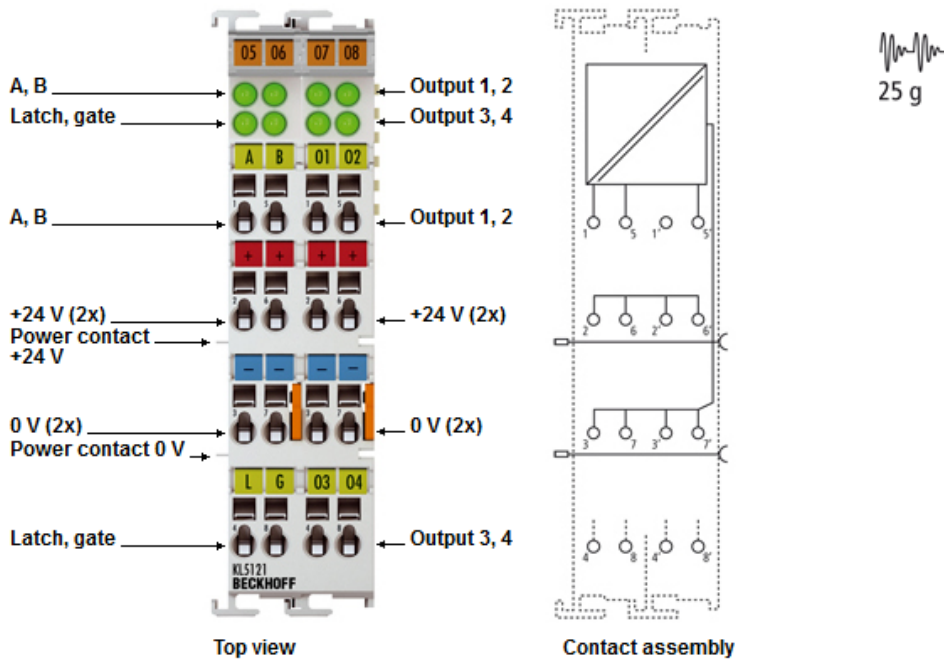

Fig. 1: KL5121

4 channel linear path control

The KL5121/KS5121 Bus Terminal can be used to implement linear path control. The terminal reads an incremental signal supplied by an incremental encoder or a pulse generator and switches the outputs at predefined counter states. The counter states can be transmitted to the terminal by the higher-level automation device in the form of a table. The position is registered with the latch input, which is activated/deactivated by the gate input. Up to four 24 V outputs can be switched. The LEDs indicate the states of the signals at the various inputs and outputs.

2.2 Technical data

Technical data	KL5121, KS5121
Encoder connection	A, B, Latch, Gate
Encoder operating voltage	24 V _{DC}
Counter	16 bit, binary
Cut-off frequency	1 million increments/s (with 4-fold evaluation)
Output voltage	24 V
Output current	0.5 A
Switching times	< 100 µs
Power supply	24 V _{DC} (-15 %/+20 %)
Current consumption power contacts	typ. 30 mA + load
Current consumption via K-bus	typ. 60 mA
Bit width in process image	input/output: 2 x 16 bit data, 2 x 8 bit control/status
Pluggable wiring	for all KSxxxx bus terminals
Weight	approx. 60 g
Permissible ambient temperature range during operation	0 °C ... + 55 °C
Permissible ambient temperature range during storage	-25 °C ... + 85 °C
Permissible relative air humidity	95 %, no condensation
Enhanced mechanical load capacity	yes, see Installation instructions for enhanced mechanical load capacity [► 15]
Vibration / shock resistance	conforms to EN 60068-2-6 / EN 60068-2-27
EMC immunity / emission	conforms to EN 61000-6-2 / EN 61000-6-4
Protection class	IP20
Installation position	variable
Approvals/markings*	CE, UKCA, cULus, EAC, ATEX [► 22]

*) Real applicable approvals/markings see type plate on the side (product marking).

Ex marking

Standard	Marking
ATEX	II 3 G Ex nA IIC T4 Gc

2.3 Basic Function Principles

Four-channel linear path control can be implemented with the KL5121 Bus Terminal. For this purpose the terminal reads in the incremental signal (which is either supplied by an encoder or by a pulse generator), obtains the position of the workpiece from another input (latch), and switches on the outputs at defined counter states which have previously been stored in the form of a table. Automatic speed correction is carried out separately for each channel (adjustable by means of registers in the terminal). The workpiece's encoder edge can be configured, so that positive edges, negative edges or both may be used. The switching times for the individual output channels are $< 100 \mu\text{S}$. A maximum of 60 switching values can be entered, and the number for each channel can vary from 0 to 60. The counter is limited to 16 bits, and tracking the workpieces is not possible.

LED display

The signal LEDs indicate the state of the encoder inputs A and B, the latch and gate logic inputs and of the four outputs O1, O2, O3 and O4.

Connections

The KL5121 has 4 logical 24 V inputs and 4 logical 24 V outputs, as well as 8 contacts for the 24 V_{DC} supply of external devices.

- A, B: sensor inputs (incremental encoder or pulse generator)
- Latch (workpiece encoder input): the latch input recognizes the workpiece, with the result that the 16 bit counter is set to zero when the latch input is activated. The latch input can be configured by way of the feature register.
- Gate (enable input): the gate enables the latch input. The gate input can be configured by way of the feature register.
- O1, O2, O3, O4: 24 V switch outputs
- 24 V/0 V: 24 V_{DC} supply voltage for the external devices (e.g. encoder)

Operation modes

Set by the control byte:

- linear path control with 4 output channels
- Alternative: PWM type of output with pre-set on and off times (nozzle test)

Process data

The KL5121 always occupies 6 bytes of input data and 6 bytes of output data. The control/status byte is located at the lowest byte offset.

There are two logical data channels:

- **Data channel 0**
for enabling the output functions and for reading the status information.
- **Data channel 1**
for transferring the switch values to the output table of the terminal.

3 Mounting and wiring

3.1 Instructions for ESD protection

NOTE

Destruction of the devices by electrostatic discharge possible!

The devices contain components at risk from electrostatic discharge caused by improper handling.

- Please ensure you are electrostatically discharged and avoid touching the contacts of the device directly.
- Avoid contact with highly insulating materials (synthetic fibers, plastic film etc.).
- Surroundings (working place, packaging and personnel) should be grounded probably, when handling with the devices.
- Each assembly must be terminated at the right hand end with a KL9010 bus end terminal, to ensure the protection class and ESD protection.

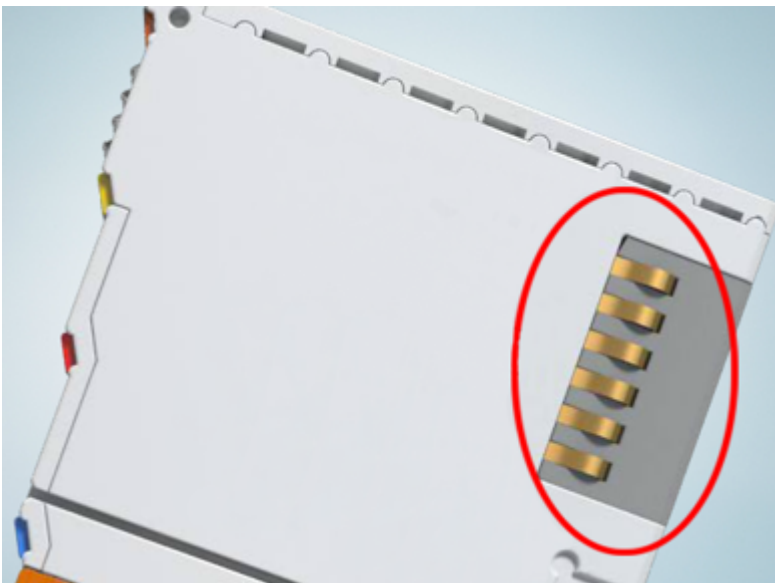

Fig. 2: Spring contacts of the Beckhoff I/O components

3.2 Installation on mounting rails

⚠ WARNING

Risk of electric shock and damage of device!

Bring the bus terminal system into a safe, powered down state before starting installation, disassembly or wiring of the bus terminals!

Assembly

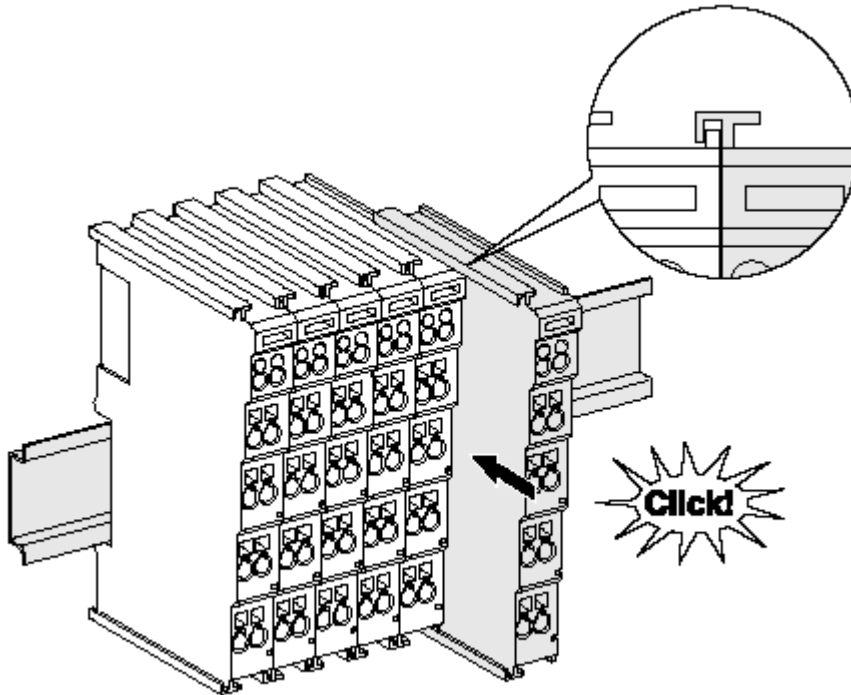

Fig. 3: Attaching on mounting rail

The bus coupler and bus terminals are attached to commercially available 35 mm mounting rails (DIN rails according to EN 60715) by applying slight pressure:

1. First attach the fieldbus coupler to the mounting rail.
2. The bus terminals are now attached on the right-hand side of the fieldbus coupler. Join the components with tongue and groove and push the terminals against the mounting rail, until the lock clicks onto the mounting rail.

If the terminals are clipped onto the mounting rail first and then pushed together without tongue and groove, the connection will not be operational! When correctly assembled, no significant gap should be visible between the housings.

i Fixing of mounting rails

The locking mechanism of the terminals and couplers extends to the profile of the mounting rail. At the installation, the locking mechanism of the components must not come into conflict with the fixing bolts of the mounting rail. To mount the mounting rails with a height of 7.5 mm under the terminals and couplers, you should use flat mounting connections (e.g. countersunk screws or blind rivets).

Disassembly

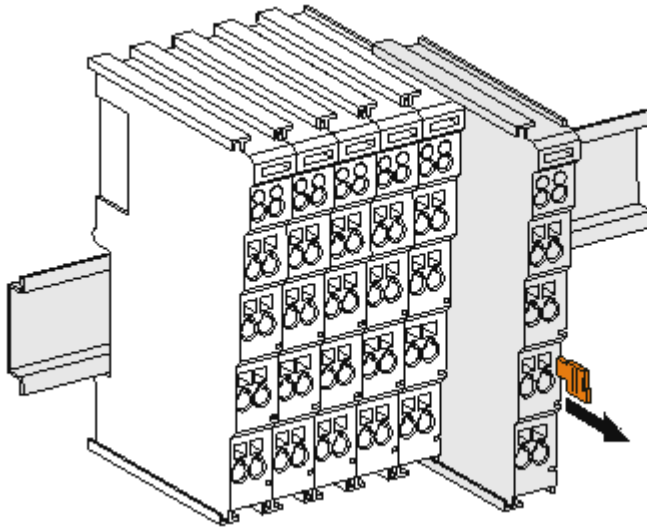

Fig. 4: Disassembling of terminal

Each terminal is secured by a lock on the mounting rail, which must be released for disassembly:

1. Pull the terminal by its orange-colored lugs approximately 1 cm away from the mounting rail. In doing so for this terminal the mounting rail lock is released automatically and you can pull the terminal out of the bus terminal block easily without excessive force.
2. Grasp the released terminal with thumb and index finger simultaneous at the upper and lower grooved housing surfaces and pull the terminal out of the bus terminal block.

Connections within a bus terminal block

The electric connections between the Bus Coupler and the Bus Terminals are automatically realized by joining the components:

- The six spring contacts of the K-Bus/E-Bus deal with the transfer of the data and the supply of the Bus Terminal electronics.
- The power contacts deal with the supply for the field electronics and thus represent a supply rail within the bus terminal block. The power contacts are supplied via terminals on the Bus Coupler (up to 24 V) or for higher voltages via power feed terminals.

i Power Contacts

During the design of a bus terminal block, the pin assignment of the individual Bus Terminals must be taken account of, since some types (e.g. analog Bus Terminals or digital 4-channel Bus Terminals) do not or not fully loop through the power contacts. Power Feed Terminals (KL91xx, KL92xx or EL91xx, EL92xx) interrupt the power contacts and thus represent the start of a new supply rail.

PE power contact

The power contact labeled PE can be used as a protective earth. For safety reasons this contact mates first when plugging together, and can ground short-circuit currents of up to 125 A.

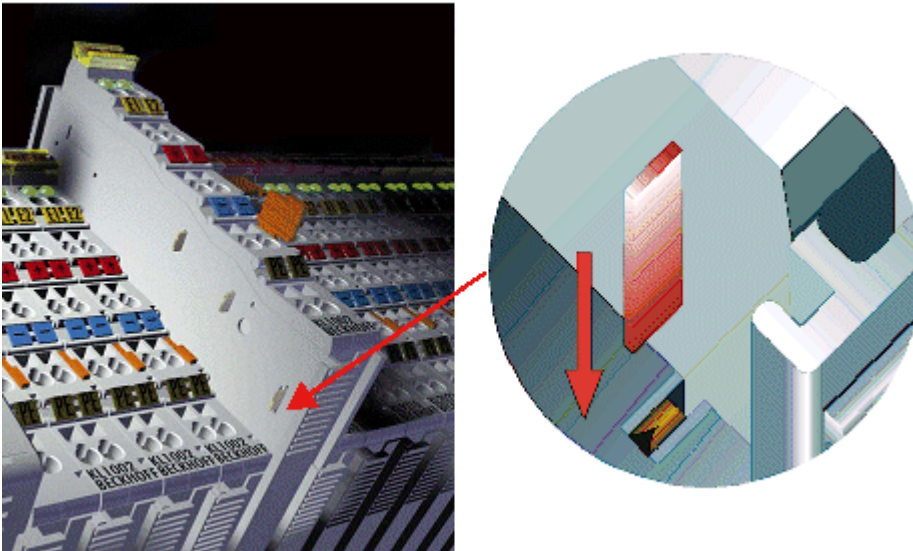

Fig. 5: Power contact on left side

NOTE**Possible damage of the device**

Note that, for reasons of electromagnetic compatibility, the PE contacts are capacitatively coupled to the mounting rail. This may lead to incorrect results during insulation testing or to damage on the terminal (e.g. disruptive discharge to the PE line during insulation testing of a consumer with a nominal voltage of 230 V). For insulation testing, disconnect the PE supply line at the Bus Coupler or the Power Feed Terminal! In order to decouple further feed points for testing, these Power Feed Terminals can be released and pulled at least 10 mm from the group of terminals.

⚠ WARNING**Risk of electric shock!**

The PE power contact must not be used for other potentials!

3.3 Installation instructions for enhanced mechanical load capacity

⚠ WARNING

Risk of injury through electric shock and damage to the device!

Bring the Bus Terminal system into a safe, de-energized state before starting mounting, disassembly or wiring of the Bus Terminals!

Additional checks

The terminals have undergone the following additional tests:

Verification	Explanation
Vibration	10 frequency runs in 3 axes
	6 Hz < f < 60 Hz displacement 0.35 mm, constant amplitude
	60.1 Hz < f < 500 Hz acceleration 5 g, constant amplitude
Shocks	1000 shocks in each direction, in 3 axes
	25 g, 6 ms

Additional installation instructions

For terminals with enhanced mechanical load capacity, the following additional installation instructions apply:

- The enhanced mechanical load capacity is valid for all permissible installation positions
- Use a mounting rail according to EN 60715 TH35-15
- Fix the terminal segment on both sides of the mounting rail with a mechanical fixture, e.g. an earth terminal or reinforced end clamp
- The maximum total extension of the terminal segment (without coupler) is: 64 terminals (12 mm mounting with) or 32 terminals (24 mm mounting with)
- Avoid deformation, twisting, crushing and bending of the mounting rail during edging and installation of the rail
- The mounting points of the mounting rail must be set at 5 cm intervals
- Use countersunk head screws to fasten the mounting rail
- The free length between the strain relief and the wire connection should be kept as short as possible. A distance of approx. 10 cm should be maintained to the cable duct.

3.4 Disposal



Products marked with a crossed-out wheeled bin shall not be discarded with the normal waste stream. The device is considered as waste electrical and electronic equipment. The national regulations for the disposal of waste electrical and electronic equipment must be observed.

3.5 Connection

3.5.1 Connection system

⚠ WARNING

Risk of electric shock and damage of device!

Bring the bus terminal system into a safe, powered down state before starting installation, disassembly or wiring of the bus terminals!

Overview

The bus terminal system offers different connection options for optimum adaptation to the respective application:

- The terminals of ELxxxx and KLxxxx series with standard wiring include electronics and connection level in a single enclosure.
- The terminals of ESxxxx and KSxxxx series feature a pluggable connection level and enable steady wiring while replacing.
- The High Density Terminals (HD Terminals) include electronics and connection level in a single enclosure and have advanced packaging density.

Standard wiring (ELxxxx / KLxxxx)



Fig. 6: Standard wiring

The terminals of ELxxxx and KLxxxx series have been tried and tested for years. They feature integrated screwless spring force technology for fast and simple assembly.

Pluggable wiring (ESxxxx / KSxxxx)



Fig. 7: Pluggable wiring

The terminals of ESxxxx and KSxxxx series feature a pluggable connection level. The assembly and wiring procedure is the same as for the ELxxxx and KLxxxx series. The pluggable connection level enables the complete wiring to be removed as a plug connector from the top of the housing for servicing. The lower section can be removed from the terminal block by pulling the unlocking tab. Insert the new component and plug in the connector with the wiring. This reduces the installation time and eliminates the risk of wires being mixed up.

The familiar dimensions of the terminal only had to be changed slightly. The new connector adds about 3 mm. The maximum height of the terminal remains unchanged.

A tab for strain relief of the cable simplifies assembly in many applications and prevents tangling of individual connection wires when the connector is removed.

Conductor cross sections between 0.08 mm² and 2.5 mm² can continue to be used with the proven spring force technology.

The overview and nomenclature of the product names for ESxxxx and KSxxxx series has been retained as known from ELxxxx and KLxxxx series.

High Density Terminals (HD Terminals)



Fig. 8: High Density Terminals

The terminals from these series with 16 terminal points are distinguished by a particularly compact design, as the packaging density is twice as large as that of the standard 12 mm bus terminals. Massive conductors and conductors with a wire end sleeve can be inserted directly into the spring loaded terminal point without tools.

● Wiring HD Terminals



The High Density Terminals of the ELx8xx and KLx8xx series doesn't support pluggable wiring.

Ultrasonically “bonded” (ultrasonically welded) conductors

● Ultrasonically “bonded” conductors



It is also possible to connect the Standard and High Density Terminals with ultrasonically “bonded” (ultrasonically welded) conductors. In this case, please note the tables concerning the wire-size width [► 18]!

3.5.2 Wiring

⚠ WARNING

Risk of electric shock and damage of device!

Bring the bus terminal system into a safe, powered down state before starting installation, disassembly or wiring of the bus terminals!

Terminals for standard wiring ELxxxx/KLxxxx and for pluggable wiring ESxxxx/KSxxxx

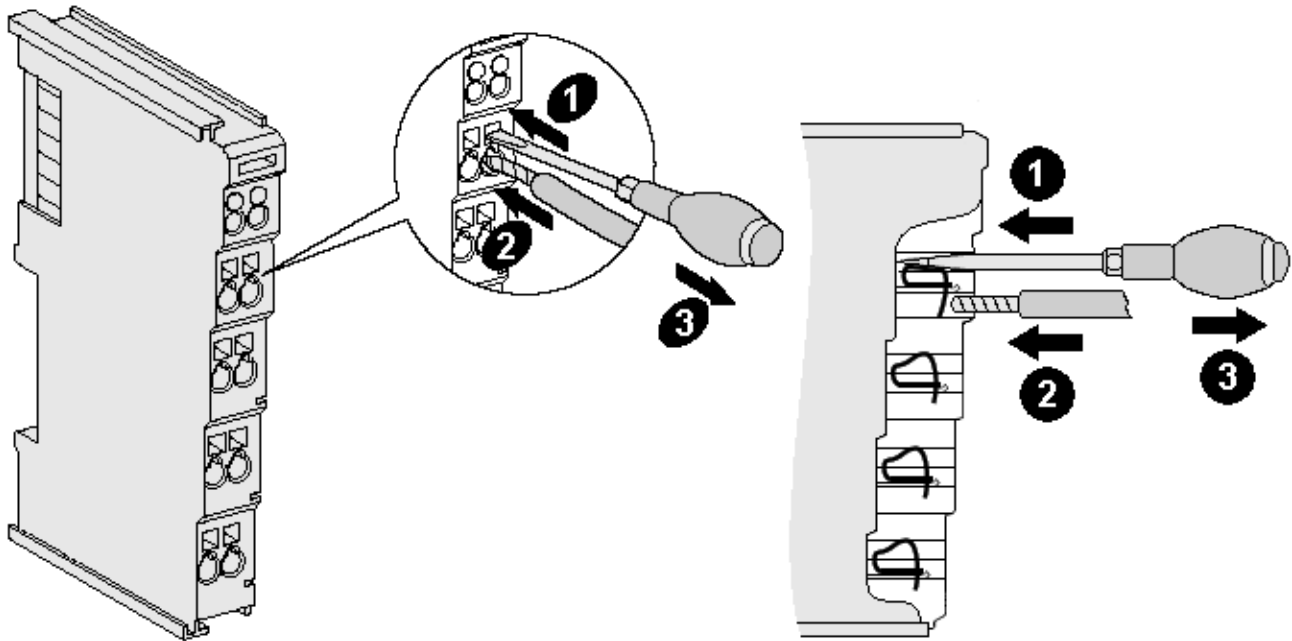

Fig. 9: Connecting a cable on a terminal point

Up to eight terminal points enable the connection of solid or finely stranded cables to the bus terminal. The terminal points are implemented in spring force technology. Connect the cables as follows:

1. Open a terminal point by pushing a screwdriver straight against the stop into the square opening above the terminal point. Do not turn the screwdriver or move it alternately (don't toggle).
2. The wire can now be inserted into the round terminal opening without any force.
3. The terminal point closes automatically when the pressure is released, holding the wire securely and permanently.

See the following table for the suitable wire size width.

Terminal housing	ELxxxx, KLxxxx	ESxxxx, KSxxxx
Wire size width (single core wires)	0.08 ... 2.5 mm ²	0.08 ... 2.5 mm ²
Wire size width (fine-wire conductors)	0.08 ... 2.5 mm ²	0.08 ... 2.5 mm ²
Wire size width (conductors with a wire end sleeve)	0.14 ... 1.5 mm ²	0.14 ... 1.5 mm ²
Wire stripping length	8 ... 9 mm	9 ... 10 mm

High Density Terminals (HD Terminals [▶ 17]) with 16 terminal points

The conductors of the HD Terminals are connected without tools for single-wire conductors using the direct plug-in technique, i.e. after stripping the wire is simply plugged into the terminal point. The cables are released, as usual, using the contact release with the aid of a screwdriver. See the following table for the suitable wire size width.

Terminal housing	High Density Housing
Wire size width (single core wires)	0.08 ... 1.5 mm ²
Wire size width (fine-wire conductors)	0.25 ... 1.5 mm ²
Wire size width (conductors with a wire end sleeve)	0.14 ... 0.75 mm ²
Wire size width (ultrasonically "bonded" conductors)	only 1.5 mm ² (see notice [▶ 17])
Wire stripping length	8 ... 9 mm

3.5.3 Shielding



Shielding

Encoder, analog sensors and actors should always be connected with shielded, twisted paired wires.

3.6 Contact assignment and LEDs

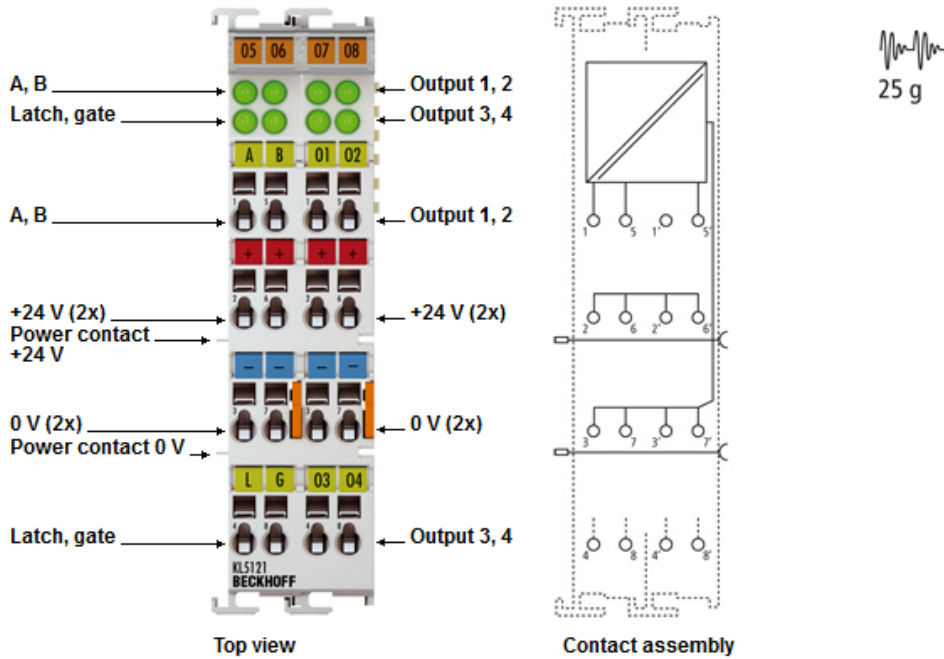

Fig. 10: KL5121 - Contact assignment and LEDs

Contact assignment

Terminal points - left part of the housing

Terminal point	No.	Contact for
A	1	Sensor input A (incremental encoder or pulse generator)
+24 V	2	+24 V supply voltage e. g. for encoder
0 V	3	0 V supply voltage e. g. for encoder
Latch	4	Latch input
B	5	Sensor input B (incremental encoder or pulse generator)
+24 V	6	+24 V supply voltage e. g. for encoder
0 V	7	0 V supply voltage e. g. for encoder
Gate	8	Gate input

Terminal points- right part of the housing

Terminal point	No.	Contact for
Output 1	1'	Switch output 1
+24 V	2'	+24 V supply voltage e. g. for encoder
0 V	3'	0 V supply voltage e. g. for encoder
Output 3	4'	Switch output 3
Output 2	5'	Switch output 2
+24 V	6'	+24 V supply voltage e. g. for encoder
0 V	7'	0 V supply voltage e. g. for encoder
Output 4	8'	Switch output 4

LED display

LED	Color	Description	
A	green	on	Input active
B	green	on	Input active
Latch	green	on	Latch input active
Gate	green	on	Gate input active
Output 1	green	on	Output 1 active
Output 2	green	on	Output 2 active
Output 3	green	on	Output 3 active
Output 4	green	on	Output 4 active

3.7 ATEX - Special conditions (standard temperature range)

⚠ WARNING

Observe the special conditions for the intended use of Beckhoff fieldbus components with standard temperature range in potentially explosive areas (directive 2014/34/EU)!

- The certified components are to be installed in a suitable housing that guarantees a protection class of at least IP54 in accordance with EN 60079-15! The environmental conditions during use are thereby to be taken into account!
- For dust (only the fieldbus components of certificate no. KEMA 10ATEX0075 X Issue 9): The equipment shall be installed in a suitable enclosure providing a degree of protection of IP54 according to EN 60079-31 for group IIIA or IIIB and IP6X for group IIIC, taking into account the environmental conditions under which the equipment is used!
- If the temperatures during rated operation are higher than 70°C at the feed-in points of cables, lines or pipes, or higher than 80°C at the wire branching points, then cables must be selected whose temperature data correspond to the actual measured temperature values!
- Observe the permissible ambient temperature range of 0 to 55°C for the use of Beckhoff fieldbus components standard temperature range in potentially explosive areas!
- Measures must be taken to protect against the rated operating voltage being exceeded by more than 40% due to short-term interference voltages!
- The individual terminals may only be unplugged or removed from the Bus Terminal system if the supply voltage has been switched off or if a non-explosive atmosphere is ensured!
- The connections of the certified components may only be connected or disconnected if the supply voltage has been switched off or if a non-explosive atmosphere is ensured!
- The fuses of the KL92xx/EL92xx power feed terminals may only be exchanged if the supply voltage has been switched off or if a non-explosive atmosphere is ensured!
- Address selectors and ID switches may only be adjusted if the supply voltage has been switched off or if a non-explosive atmosphere is ensured!

Standards

The fundamental health and safety requirements are fulfilled by compliance with the following standards:

- EN 60079-0:2012+A11:2013
- EN 60079-15:2010
- EN 60079-31:2013 (only for certificate no. KEMA 10ATEX0075 X Issue 9)

Marking

The Beckhoff fieldbus components with standard temperature range certified according to the ATEX directive for potentially explosive areas bear one of the following markings:



II 3G KEMA 10ATEX0075 X Ex nA IIC T4 Gc Ta: 0 ... +55°C

II 3D KEMA 10ATEX0075 X Ex tc IIIC T135°C Dc Ta: 0 ... +55°C
(only for fieldbus components of certificate no. KEMA 10ATEX0075 X Issue 9)

or



II 3G KEMA 10ATEX0075 X Ex nA nC IIC T4 Gc Ta: 0 ... +55°C

II 3D KEMA 10ATEX0075 X Ex tc IIIC T135°C Dc Ta: 0 ... +55°C
(only for fieldbus components of certificate no. KEMA 10ATEX0075 X Issue 9)

3.8 Continulative documentation for ATEX and IECEx

NOTE**Continulative documentation about explosion protection according to ATEX and IECEx**

Pay also attention to the continuative documentation

Ex. Protection for Terminal Systems

Notes on the use of the Beckhoff terminal systems in hazardous areas according to ATEX and IECEx,

that is available for [download](#) within the download area of your product on the Beckhoff homepage www.beckhoff.com!

4 Configuration Software KS2000

4.1 KS2000 - Introduction

The KS2000 configuration software permits configuration, commissioning and parameterization of bus couplers, of the affiliated bus terminals and of Fieldbus Box Modules. The connection between bus coupler / Fieldbus Box Module and the PC is established by means of the serial configuration cable or the fieldbus.



Fig. 11: KS2000 configuration software

Configuration

You can configure the Fieldbus stations with the Configuration Software KS2000 offline. That means, setting up a terminal station with all settings on the couplers and terminals resp. the Fieldbus Box Modules can be prepared before the commissioning phase. Later on, this configuration can be transferred to the terminal station in the commissioning phase by means of a download. For documentation purposes, you are provided with the breakdown of the terminal station, a parts list of modules used and a list of the parameters you have modified. After an upload, existing fieldbus stations are at your disposal for further editing.

Parameterization

KS2000 offers simple access to the parameters of a fieldbus station: specific high-level dialogs are available for all bus couplers, all intelligent bus terminals and Fieldbus Box modules with the aid of which settings can be modified easily. Alternatively, you have full access to all internal registers of the bus couplers and intelligent terminals. Refer to the register description for the meanings of the registers.

Commissioning

The KS2000 software facilitates commissioning of machine components or their fieldbus stations: Configured settings can be transferred to the fieldbus modules by means of a download. After a *login* to the terminal station, it is possible to define settings in couplers, terminals and Fieldbus Box modules directly *online*. The same high-level dialogs and register access are available for this purpose as in the configuration phase.

The KS2000 offers access to the process images of the bus couplers and Fieldbus Box modules.

- Thus, the coupler's input and output images can be observed by monitoring.
- Process values can be specified in the output image for commissioning of the output modules.

All possibilities in the *online mode* can be used in parallel with the actual fieldbus mode of the terminal station. The fieldbus protocol always has the higher priority in this case.

5 Access from the user program

5.1 KL5121 –Terminal configuration

Each terminal channel is mapped in the Bus Coupler. Depending on the type of the Bus Coupler and the mapping configuration (e.g. Motorola/Intel format, word alignment etc.) the terminal data are mapped in different ways to the Bus Coupler memory.

In contrast to analog input and output terminals, the KL5121 always also maps the control and status byte, independently of the higher-level fieldbus system.

BK2000 Lightbus Coupler

With the BK2000 Lightbus Coupler, the control/status byte is always mapped in addition to the data bytes (i.e. for all analog terminals). This is always in the low byte on the offset address of the terminal channel.

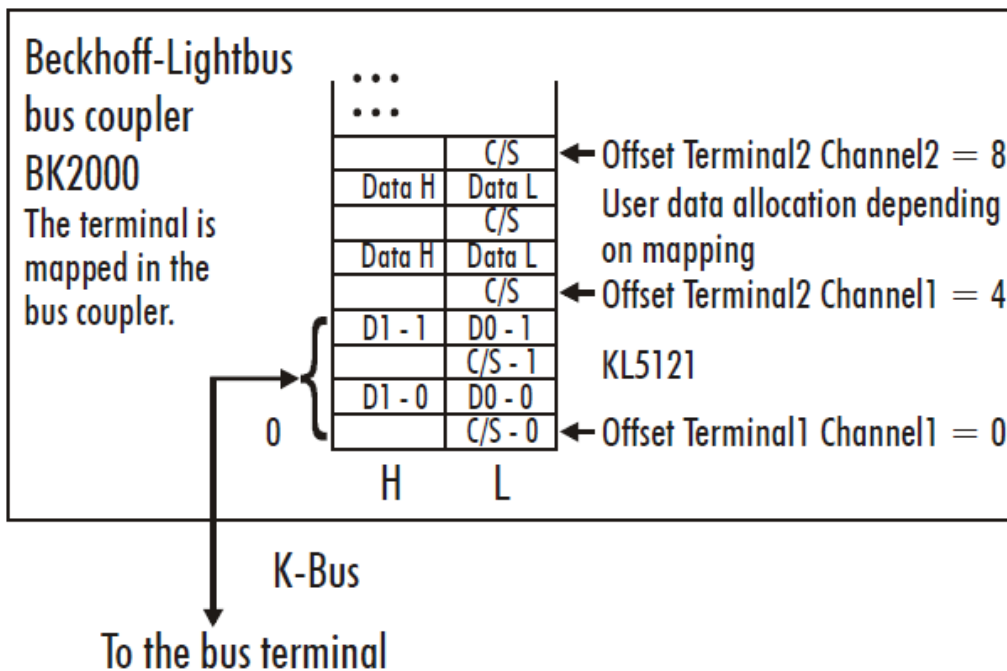

Fig. 12: Mapping for Lightbus Coupler - sample KL5121

BK3000 PROFIBUS Coupler

In the BK3000 Profibus coupler, the KL5121 is always mapped with 6 bytes of input data and 6 bytes of output data.

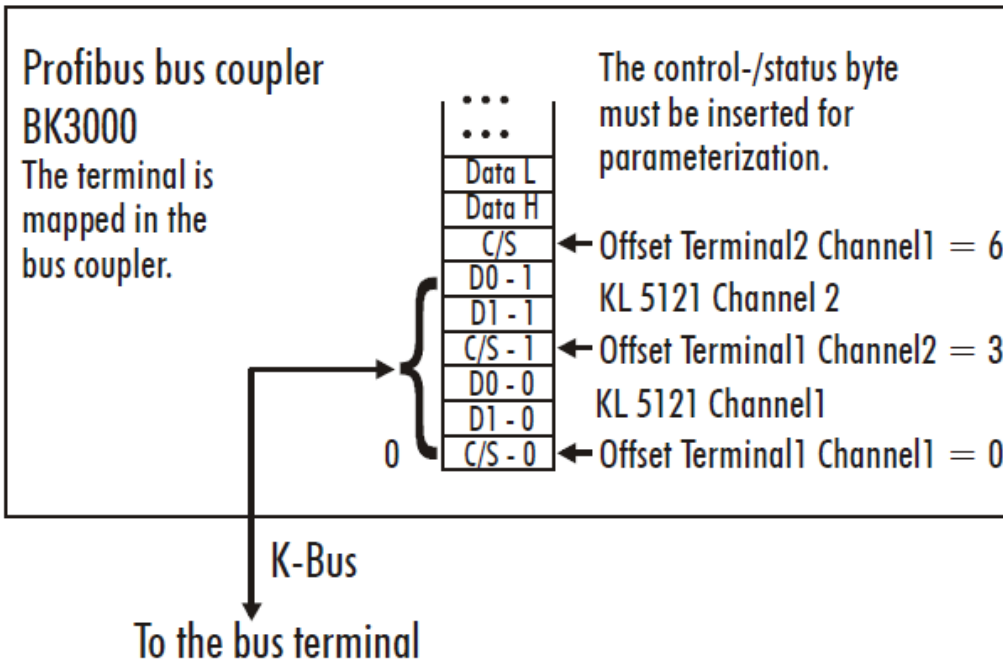

Fig. 13: Mapping for Profibus Coupler - example for KL5121

BK4000 Interbus Coupler

The BK4000 Interbus Coupler normally maps the KL5121 with 6 bytes of input data and 6 bytes of output data.

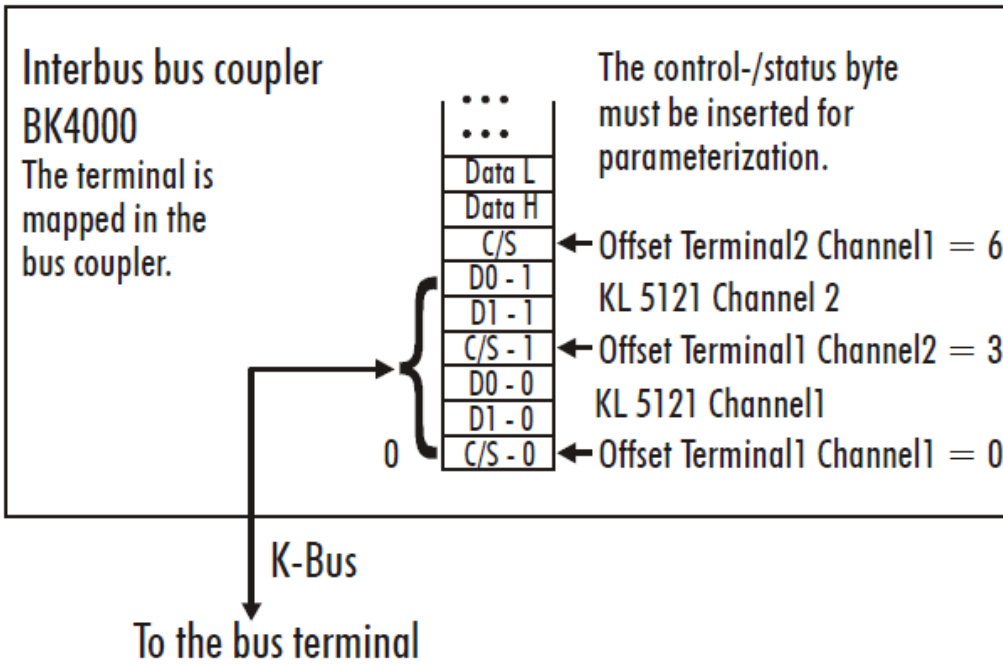

Fig. 14: Mapping for Interbus Coupler - sample for KL5121

Other Bus Couplers and further information

Further information about the mapping configuration of Bus Couplers can be found in the Appendix of the respective Bus Coupler manual under *Master configuration*.

The chapter on [Mapping in the Bus Coupler](#) [▶ 28] contains an overview of possible mapping configurations, depending on the configurable parameters.

i Parameterization with KS2000

The KS2000 configuration software can be used for parameterizations via the serial interface of the Bus Coupler, independent of the fieldbus system.

5.2 Mapping in the Bus Coupler

As already described in the *Terminal Configuration* section, each Bus Terminal is mapped in the Bus Coupler. This mapping is usually done with the default setting in the Bus Coupler / Bus Terminal. The KS2000 configuration software or a master configuration software (e.g. ComProfibus or TwinCAT System Manager) can be used to change this default setting.

If the terminals are fully evaluated, they occupy memory space in the input and output process image.

The following tables provide information about how the terminals map themselves in the Bus Coupler, depending on the parameters set.

5.2.1 Standard format

The KL5121 is mapped into the bus coupler depending on the set parameters. The terminal always occupies memory space in the process image of the inputs **and** outputs.

Default: CANCAL, CANopen, DeviceNet, RS232, RS485 and ControlNet Coupler

Conditions	Word offset	High byte	Low byte
Complete evaluation: any	0	D0-0	CT/ST-0
Motorola format: no	1	CT/ST-0	D1-0
Word alignment: no	2	D1-1	D0-1
	3		

Default: Interbus and Profibus Coupler

Conditions	Word offset	High byte	Low byte
Complete evaluation: any	0	D1-0	CT/ST-0
Motorola format: yes	1	CT/ST-0	D0-0
Word alignment: no	2	D0-1	D1-1
	3		

Default: Lightbus, Ethernet and EtherCAT Coupler and Bus Terminal Controller (BCxxxx, BXxxxx)

Conditions	Word offset	High byte	Low byte
Complete evaluation: any	0	-	CT/ST-0
Motorola format: no	1	D1-0	D0-0
Word alignment: yes	2	-	CT/ST-0
	3	D1-1	D0-1

Conditions	Word offset	High byte	Low byte
Complete evaluation: any	0	-	CT/ST-0
Motorola format: yes	1	D0-0	D1-0
Word alignment: yes	2	-	CT/ST-0
	3	D0-1	D1-1

Key

Complete evaluation	The terminal is mapped with control and status byte.
Motorola format	Motorola or Intel format can be set.
Word alignment	The terminal is positioned on a word limit in the Bus Coupler.
CB	Control byte (appears in the process image of the outputs).
SB	Status byte (appears in the process image of the inputs).
D0/D1	Counter word (read/set)
(D2)	The period duration is output here, together with D3/D4.
D3/D4	Latch word (read)
“_“	This byte is not used or occupied by the terminal.

5.3 Register overview

Address	Name	Default value	R/W	Storage medium
R0	Pulses for speed factor 1	variable	R	RAM
R1	Pulses for speed factor 2	variable	R	RAM
R2	Pulses for speed factor 3	variable	R	RAM
R3	Pulses for speed factor 4	variable	R	RAM
R4, R5	reserved	0x0000	R	
R6	Diagnostic register not used	0x0000	R	
R7	Command register not used	0x0000	R	
R8	Terminal type	5121	R	ROM
R9	Firmware version	0x????	R	ROM
R10	Multiplex shift register	0x0218	R	ROM
R11	Signal channels	0x0130	R	ROM
R12	Minimum data length	0x3030	R	ROM
R13	Data structure	0x0000	R	ROM
R14	reserved	0x0000	R	
R15	Alignment register	variable	R/W	RAM
R16	Hardware version	0x????	R/W	SEEROM
R17...R28	reserved	0x0000	R/W	SEEROM
R29	Changed default setting	variable	R/W	SEEROM
R30	reserved	0x0000	R/W	SEEROM
R31	Code word register	variable	R/W	RAM
R32	Feature register	0x0000	R/W	SEEROM
R33	Pulse duration T_i for channel 1	0x01F4	R/W	SEEROM
R34	Rate time T_v for channel 1	0x1388	R/W	SEEROMR
R35	Period T_d for the channel 1 nozzle test	0x4E20	R/W	SEEROM
R36...R39	reserved	0x0000	R/W	SEEROM
R40	Feature register 2	0x0000	R/W	SEEROM
R41	Pulse duration T_i for channel 2	0x01F4	R/W	SEEROM
R42	Rate time T_v for channel 2	0x1388	R/W	SEEROM
R43	Period T_d for the channel 2 nozzle test	0x4E20	R/W	SEEROM
R44...R47	reserved	0x0000	R/W	SEEROM
R48	Feature register 3	0x0000	R/W	SEEROM
R49	Pulse duration T_i for channel 3	0x01F4	R/W	SEEROM
R50	Rate time T_v for channel 3	0x1388	R/W	SEEROM
R51	Period T_d for the channel 3 nozzle test	0x4E20	R/W	SEEROM
R52...R55	reserved	0x0000	R/W	SEEROM
R56	Feature register 4	0x0000	R/W	SEEROM
R57	Pulse duration T_i for channel 4	0x01F4	R/W	SEEROM
R58	Rate time T_v for channel 4	0x1388	R/W	SEEROM
R59	Period T_d for the channel 4 nozzle test	0x4E20	R/W	SEEROM
R60...R63	reserved	0x0000	R/W	SEEROM

5.4 Register description

The registers can be read or written via the register communication. They are used for the parameterization of the terminal.

General description of registers

Complex terminals that possess a processor are able to exchange data bi-directionally with the higher-level controller. These terminals are referred to below as intelligent Bus Terminals. These include the analog inputs (0 to 10 V, -10 to 10 V, 0 to 20 mA, 4 to 20 mA), the analog outputs (0 to 10 V, -10 to 10 V, 0 to 20 mA, 4 to 20 mA), serial interface terminals (RS485, RS232, TTY, data exchange terminals), counter terminals, encoder interfaces, SSI interfaces, PWM terminals and all other parameterizable modules.

The main features of the internal data structure are the same for all the intelligent terminals. This data area is organized as words, and includes 64 memory locations. The important data and parameters of the terminal can be read and set through this structure. It is also possible for functions to be called by means of corresponding parameters. Each logical channel in an intelligent terminal has such a structure (so a 4-channel analog terminal has 4 register sets).

This structure is divided into the following areas:

Range	Register number
Process variables	0 to 7
Type register	8 to 15
Manufacturer parameters	16 to 30
User parameters	31 to 47
Extended user area	48 to 63

R0 to R7: Registers in the internal RAM of the terminal

The process variables can be used in addition to the actual process image. Their function is specific to the terminal.

- **R0 to R5: reserved**
- **R0 to R3**
Pulse for speed correction of channels 1-4
- **R4 to R7: no function**
- **R6: Diagnostic register**
The diagnostic register can contain additional diagnostic information. Parity errors, for instance, that occur in serial interface terminals during data transmission are indicated here.
- **R7: Command register**
High-Byte_Write = function parameter
Low-Byte_Write = function number
High-Byte_Read = function result
Low-Byte_Read = function number

R8 to R15: Registers in the internal ROM of the terminal

The type and system parameters are hard programmed by the manufacturer, and the user can read them but cannot change them.

- **R8: Terminal type**
The terminal type in register R8 is needed to identify the terminal.
- **R9: Software version (X.y)**
The software version can be read as a string of ASCII characters.
- **R10: Data length**
R10 contains the number of multiplexed shift registers and their length in bits.
The Bus Coupler sees this structure.

- **R11: Signal channels**

Related to R10, this contains the number of channels that are logically present. Thus for example a shift register that is physically present can perfectly well consist of several signal channels.

- **R12: Minimum data length**

The particular byte contains the minimum data length for a channel that is to be transferred. If the MSB is set, the control and status byte is not necessarily required for the terminal function and is not transferred to the control, if the Bus Coupler is configured accordingly.

- **R13: Data type register**

Data type register	Meaning
0x00	Terminal with no valid data type
0x01	Byte array
0x02	Structure 1 byte n bytes
0x03	Word array
0x04	Structure 1 byte n words
0x05	Double word array
0x06	Structure 1 byte n double words
0x07	Structure 1 byte 1 double word
0x08	Structure 1 byte 1 double word
0x11	Byte array with variable logical channel length
0x12	Structure 1 byte n bytes with variable logical channel length (e.g. 60xx)
0x13	Word array with variable logical channel length
0x14	Structure 1 byte n words with variable logical channel length
0x15	Double word array with variable logical channel length
0x16	Structure 1 byte n double words with variable logical channel length

- **R14: reserved**

- **R15: Alignment bits (RAM)**

The alignment bits are used to place the analog terminal in the Bus Coupler on a byte boundary.

R16 to R30: Manufacturer parameter area (SEEROM)

The manufacturer parameters are specific for each type of terminal. They are programmed by the manufacturer, but can also be modified by the controller. The manufacturer parameters are stored in a serial EEPROM in the terminal, and are retained in the event of voltage drop-out.

These registers can only be altered after a code word has been set in R31 [► 32].

- **R17 to R30: not used**

R31 to R47: User parameter area (SEEROM)

The user parameters are specific for each type of terminal. They can be modified by the programmer. The user parameters are stored in a serial EEPROM in the terminal, and are retained in the event of voltage drop-out. The user area is write-protected by a code word.

- **R31: Code word register in RAM**

I The code word **0x1235** must be entered here so that parameters in the user area can be modified. If any other value is entered into this register, the write-protection is active. When write protection is not active, the code word is returned when the register is read. If the write protection is active, the register contains a zero value.

- **R32: Feature register**

This register specifies the operation modes of the terminal. Thus, for instance, a user-specific scaling can be enabled for the analog I/Os.

This register describes the hardware settings for channels 1-4 [0x0062]

The default values are shown in square brackets.

Feature bit no.		Description of the operation mode
Bit 0	0/1	0: encoder operating mode with 4-fold evaluation [0] 1: up/down counter (pulse generator) with A as counter input and B as U/D input
Bit 1	0/1	Latch input: 0: rising edge is ignored 1: evaluate positive edge as start signal [1]
Bit 2	0/1	Latch input: 0: falling edge is ignored [0] 1: evaluate negative edge as start signal
Bit 3	0/1	0: the outputs are switched according to positive logic [0] 1: the outputs are switched according to negative logic
Bit 4	0/1	0: watchdog timer active [0] 1: watchdog timer active. If the terminal does not receive any process data from the K-bus for 100 ms the outputs are reset
Bit 5	1	1: workpiece encoder input (latch) is active [1] when there is a positive level at the enable input (gate)
Bit 6	1	1: workpiece encoder input (latch) is active [1] when there is a negative level at the enable input (gate)
Bit 7 - 11	-	not used
Bit 12 - 15	0000 0001	Pulse operation (R33-R35 activated) [0000] Line operation (not yet implemented)

- **R33 - R47**
Registers that depend on the terminal type.
- **R33: Pulse duration T_i for channel 1**
[0x01F4] = 0.5 ms
 T_i defines the pulse duration in pulse mode of channel 1 [μ s]
- **R34: Rate time T_v for channel 1**
[0x1388] = 5 ms
The pulses counted over the rate time T_v are calculated during the velocity correction [μ s]
- **R35: Period T_d for channel 1**
[0x4E20] = 20 ms
Period T_d for the channel 1 nozzle test
- **R40 - R43: Channel 2 register**
- **R47 - R63**
Extended registers with additional functions.
- **R48 - R51: Channel 3 register**
- **R56 - R59: Channel 4 register**

5.5 Control and status byte

5.5.1 Process data exchange

Process data

The KL5121 terminal occupies 6 bytes in the coupler's input process image and 6 bytes in the output process image. There are two logical channels: data channel 0 and data channel 1.

Data channel 0

Data channel 0 consists of control byte 0, input data word 0, status byte 0 and output data word 0. Enables for the output functions are communicated through channel 0, and status information is read in. Parameter data can also be accessed.

Controller output data

CT-0: Control byte 0
D0-0, D1-0: the terminal's input data word 0

Controller input data

ST-0: Status byte 0
D0-0, D1-0: the terminal's output data word 0

Control byte 0

Control byte 0 is only used for register access

MSB

REG = 0							
---------	--	--	--	--	--	--	--

Status byte 0

The state of the inputs can be read through status byte 0.

REG = 0	ERROR_BIT (reserved)				A_INPUT	B_INPUT	LATCH_INPUT
---------	----------------------	--	--	--	---------	---------	-------------

Output data word 0

The current counter value is read in output data word 0 of the terminal. The terminal supplies the output data word 0.

Bit no.	Meaning
Bit 0 - 15	Current encoder counter state

Input data word 0

Input data word 0 of the terminal is used for channel-specific enables. A nibble of the data word is reserved for each channel.

Channel 1

Nibble	Meaning
0000	No enable is present. If the automatic switching function was previously active, it is reset, so that if a workpiece has already been picked up it will not be processed further when the automatic function becomes active again.
0001	Enable for the automatic switching function
0111	Enable for the "glue nozzle test". If the automatic switching function was previously active it is interrupted, and is continued again when there is a change of operation mode, provided that the enable is not reset (e.g. from 0001 to 0111 to 0001)
0011	Output to high level. Interruption of the switching function if it was previously active.
0101	Output to low level. Interruption of the switching function if it was previously active.

The other nibbles for channels 2 - 4 are occupied similarly.

Data channel 1

Data channel 1 transfers the switch values to the terminal. They are temporarily stored in the terminal's RAM. Access to this data set is identical to access to the terminal's register set.

Controller output data

CT-1: Control byte 1
 D0-1, D1-1: input data word 1 of the terminal

Controller input data

ST-1: Status byte 1
 D0-1, D1-1: output data word 1 of the terminal

Control byte 1

Control byte 1 is transmitted from the controller to the terminal, and is used for access to the output table.

Bit no.		Meaning
Bit 0 - 5	000000-111111	Address bits A0 to A5 of the output table
Bit 6	0/1	0: Read 1: Write
Bit 7	0/1	Table bit This bit must be set for table accesses. If the controller sees a falling edge in the terminal here, evaluation of the output table is started, so that, if sorting or other tasks are necessary, they will be performed.

Status byte 1

Status byte 1 is transmitted from the terminal to the controller.

Bit no.:		Meaning
Bit 0 - 5	000000-111111	Address bits A0 to A5 of the output table
Bit 6	0/1	don't care
Bit 7	1	Acknowledge for table access

Output data word 1

Output data word AW1 returns the addressed table entry when a table is accessed.

Bit no.	Meaning
Bit 0 - 15	Content of the addressed table entry

Input data word 1

Input data word EW1 is entered into the table during a write access by the controller.

Bit no.	Meaning
Bit 0 - 15	Entry in the output table

Output table

The appropriate values for the corresponding function must be entered into the output table (max. 60 switching values).

Index	Entry
0	Number N of entries for the first output
1	Number M of entries for the second output
2	Number O of entries for the third output
3	Number P of entries for the fourth output
4	Switch value 1 channel 1
...	
N+4	Switch value N channel 1
N+5	Switch value 1 channel 2
...	
N+M+4	Switch value M channel 2
N+M+5	Switch value 1 channel 3
...	
N+M+O+4	Switch value O channel 3
N+M+O+5	Switch value 1 channel 4
N+M+O+P+4	Switch value P channel 4

5.5.2 Register communication

Register access via process data exchange

- **Bit 7=1: Register mode**

If bit 7 of the control byte is set, the first two bytes of the user data are not used for process data exchange but written into the register set of the terminal or read from it.

- **Bit 6=0: read, bit 6=1: write**

Bit 6 of the control bytes is used to specify whether a register should be read or written.

- **Bit 6=0:** A register is read without changing it. The value can be found in the input process image.
- **Bit 6=1:** The user data are written into a register. The process is complete once the status byte in the input process image has returned an acknowledgment (see example).

- **Bit 0 to 5: Address**

The address of the register to be addressed is entered in bits 0 to 5 of the control byte

Control byte in the register mode

MSB

REG = 1	W/R	A5	A4	A3	A2	A1	A0
---------	-----	----	----	----	----	----	----

REG = 0: Process data exchange

REG = 1: Access to register structure

W/R = 0: Read register

W/R = 1: Write register

A5...A0 = register address

Addresses A5...A0 can be used to address a total of 64 registers

Examples for the register communication

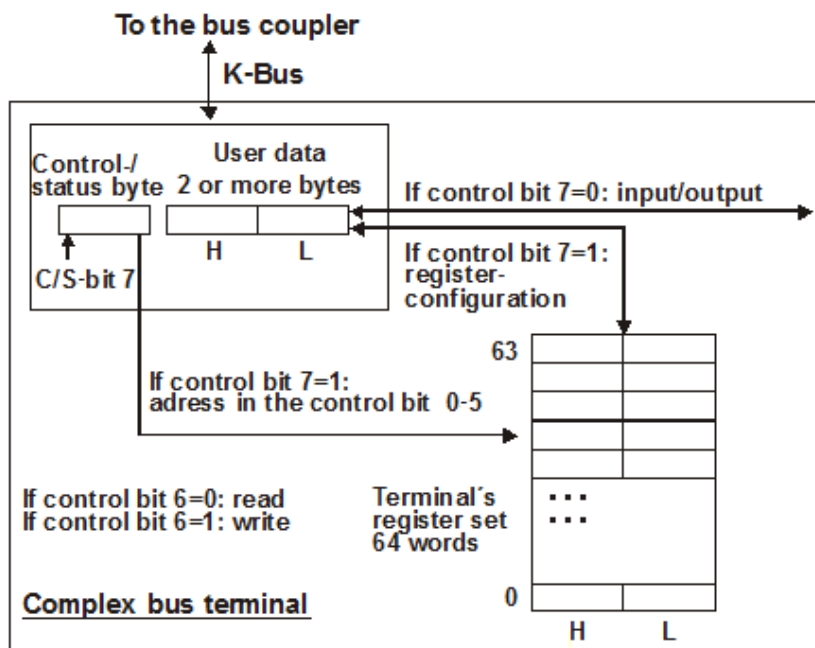

Fig. 15: Register mode control byte

The control or status byte occupies the lowest address of a logical channel. The corresponding register values are located in the following 2 data bytes. (The BK2000 is an exception: here, an unused data byte is inserted after the control or status byte, and the register value is therefore placed on a word boundary).

Sample 1

Reading register 8 in the BK2000 with a KL5121 and the end terminal:

If the following bytes are transferred from the controller to the terminal,

Byte	Byte 3	Byte 2	Byte 1	Byte 0
Name	DataOUT 1, low byte	DataOUT 0, high byte	Not used	Control byte
Value	0xXX	0xXX	0xXX	0x88

The terminal returns the following type identifier (0x1401 corresponds to unsigned integer 5121).

Byte	Byte 3	Byte 2	Byte 1	Byte 0
Name	DataIN 1, low byte	Data IN 0, high byte	Not used	Status byte
Value	0x01	0x14	0x00	0x88

Sample 2

Writing of register 31 in the BK2000 with an intelligent terminal and the end terminal:

If the following bytes (user code word) are transferred from the controller to the terminal,

Byte	Byte 3	Byte 2	Byte 1	Byte 0
Name	DataOUT, low byte	DataOUT, high byte	Not used	Control byte
Value	0x35	0x12	0xXX	0xDF

the user code word is set and the terminal returns the register address with the bit 7 for register access as acknowledgement.

Byte	Byte 3	Byte 2	Byte 1	Byte 0
Name	DataIN 1	DataIN 0	Not used	Status byte
Value	0x00	0x00	0x00	0x9F

5.6 Examples of Register Communication

The numbering of the bytes in the examples corresponds to the display without word alignment.

5.6.1 Example 1: Reading the firmware version from register 9

Output Data

Byte 0: Control byte	Byte 1: DataOUT1, high byte	Byte 2: DataOUT1, low byte
0x89 (1000 1001 _{bin})	0xXX	0xXX

Explanation:

- Bit 0.7 set means: Register communication switched on.
- Bit 0.6 not set means: reading the register.
- Bits 0.5 to 0.0 specify the register number 9 with 00 1001_{bin}.
- The output data word (byte 1 and byte 2) has no meaning during read access. To change a register, write the required value into the output word.

Input Data (answer of the Bus Terminal)

Byte 0: Status byte	Byte 1: DataIN1, high byte	Byte 2: DataIN1, low byte
0x89	0x33	0x41

Explanation:

- The terminal returns the value of the control byte as a receipt in the status byte.
- The terminal returns the firmware version 0x3341 in the input data word (byte 1 and byte 2). This is to be interpreted as an ASCII code:
 - ASCII code 0x33 represents the digit 3
 - ASCII code 0x41 represents the letter A
 The firmware version is thus 3A.

5.6.2 Example 2: Writing to an user register



Code word

In normal mode all user registers are read-only with the exception of Register 31. In order to deactivate this write protection you must write the code word (0x1235) into Register 31. If a value other than 0x1235 is written into Register 31, write protection is reactivated. Please note that changes to a register only become effective after restarting the terminal (power-off/power-on).

I. Write the code word (0x1235) into register 31.

Output Data

Byte 0: Control byte	Byte 1: DataOUT1, high byte	Byte 2: DataOUT1, low byte
0xDF (1101 1111 _{bin})	0x12	0x35

Explanation:

- Bit 0.7 set means: Register communication switched on.
- Bit 0.6 set means: writing to the register.
- Bits 0.5 to 0.0 specify the register number 31 with 01 1111_{bin}.
- The output data word (byte 1 and byte 2) contains the code word (0x1235) for deactivating write protection.

Input Data (answer of the Bus Terminal)

Byte 0: Status byte	Byte 1: DataIN1, high byte	Byte 2: DataIN1, low byte
0x9F (1001 1111 _{bin})	0xFF	0xFF

Explanation:

- The terminal returns a value as a receipt in the status byte that differs only in bit 0.6 from the value of the control byte.
- The input data word (byte 1 and byte 2) is of no importance after the write access. Any values still displayed are invalid!

II. Read Register 31 (check the set code word)

Output Data

Byte 0: Control byte	Byte 1: DataOUT1, high byte	Byte 2: DataOUT1, low byte
0x9F (1001 1111 _{bin})	0xFF	0xFF

Explanation:

- Bit 0.7 set means: Register communication switched on.
- Bit 0.6 not set means: reading the register.
- Bits 0.5 to 0.0 specify the register number 31 with 01 1111_{bin}.
- The output data word (byte 1 and byte 2) has no meaning during read access.

Input Data (answer of the Bus Terminal)

Byte 0: Status byte	Byte 1: DataIN1, high byte	Byte 2: DataIN1, low byte
0x9F (1001 1111 _{bin})	0x12	0x35

Explanation:

- The terminal returns the value of the control byte as a receipt in the status byte.

- The terminal returns the current value of the code word register in the input data word (byte 1 and byte 2).

III. Write to Register 32 (change contents of the feature register)

Output data

Byte 0: Control byte	Byte 1: DataIN1, high byte	Byte 2: DataIN1, low byte
0xE0 (1110 0000 _{bin})	0x00	0x02

Explanation:

- Bit 0.7 set means: Register communication switched on.
- Bit 0.6 set means: writing to the register.
- Bits 0.5 to 0.0 indicate register number 32 with 10 0000_{bin}.
- The output data word (byte 1 and byte 2) contains the new value for the feature register.

⚠ CAUTION

Observe the register description!

The value of 0x0002 given here is just an example!

The bits of the feature register change the properties of the terminal and have a different meaning, depending on the type of terminal. Refer to the description of the feature register of your terminal (chapter *Register description*) regarding the meaning of the individual bits before changing the values.

Input data (response from the Bus Terminal)

Byte 0: Status byte	Byte 1: DataIN1, high byte	Byte 2: DataIN1, low byte
0xA0 (1010 0000 _{bin})	0xFF	0xFF

Explanation:

- The terminal returns a value as a receipt in the status byte that differs only in bit 0.6 from the value of the control byte.
- The input data word (byte 1 and byte 2) is of no importance after the write access. Any values still displayed are invalid!

IV. Read register 32 (check changed feature register)

Output Data

Byte 0: Control byte	Byte 1: DataOUT1, high byte	Byte 2: DataOUT1, low byte
0xA0 (1010 0000 _{bin})	0xFF	0xFF

Explanation:

- Bit 0.7 set means: Register communication switched on.
- Bit 0.6 not set means: reading the register.
- Bits 0.5 to 0.0 indicate register number 32 with 10 0000_{bin}.
- The output data word (byte 1 and byte 2) has no meaning during read access.

Input Data (answer of the Bus Terminal)

Byte 0: Status byte	Byte 1: DataIN1, high byte	Byte 2: DataIN1, low byte
0xA0 (1010 0000 _{bin})	0x00	0x02

Explanation:

- The terminal returns the value of the control byte as a receipt in the status byte.

- The terminal returns the current value of the feature register in the input data word (byte 1 and byte 2).

V. Write register 31 (reset code word)

Output Data

Byte 0: Control byte	Byte 1: DataOUT1, high byte	Byte 2: DataOUT1, low byte
0xDF (1101 1111 _{bin})	0x00	0x00

Explanation:

- Bit 0.7 set means: Register communication switched on.
- Bit 0.6 set means: writing to the register.
- Bits 0.5 to 0.0 specify the register number 31 with 01 1111_{bin}.
- The output data word (byte 1 and byte 2) contains 0x0000 for reactivating write protection.

Input Data (answer of the Bus Terminal)

Byte 0: Status byte	Byte 1: DataIN1, high byte	Byte 2: DataIN1, low byte
0x9F (1001 1111 _{bin})	0xFF	0xFF

Explanation:

- The terminal returns a value as a receipt in the status byte that differs only in bit 0.6 from the value of the control byte.
- The input data word (byte 1 and byte 2) is of no importance after the write access. Any values still displayed are invalid!

6 Appendix

6.1 Beckhoff Identification Code (BIC)

The Beckhoff Identification Code (BIC) is increasingly being applied to Beckhoff products to uniquely identify the product. The BIC is represented as a Data Matrix Code (DMC, code scheme ECC200), the content is based on the ANSI standard MH10.8.2-2016.

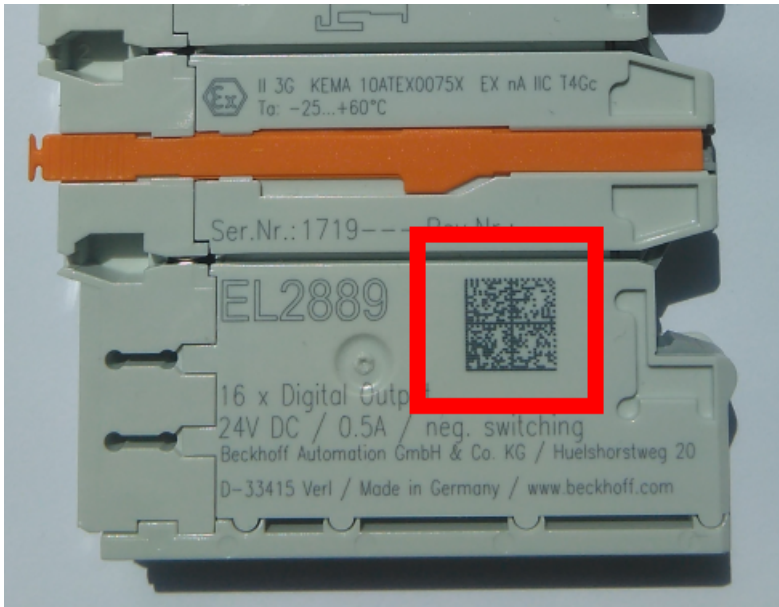

Fig. 16: BIC as data matrix code (DMC, code scheme ECC200)

The BIC will be introduced step by step across all product groups.

Depending on the product, it can be found in the following places:

- on the packaging unit
- directly on the product (if space suffices)
- on the packaging unit and the product

The BIC is machine-readable and contains information that can also be used by the customer for handling and product management.

Each piece of information can be uniquely identified using the so-called data identifier (ANSI MH10.8.2-2016). The data identifier is followed by a character string. Both together have a maximum length according to the table below. If the information is shorter, spaces are added to it.

Following information is possible, positions 1 to 4 are always present, the other according to need of production:

Position	Type of information	Explanation	Data identifier	Number of digits incl. data identifier	Example
1	Beckhoff order number	Beckhoff order number	1P	8	1P 072222
2	Beckhoff Traceability Number (BTN)	Unique serial number, see note below	SBTN	12	SBTN k4p562d7
3	Article description	Beckhoff article description, e.g. EL1008	1K	32	1K EL1809
4	Quantity	Quantity in packaging unit, e.g. 1, 10, etc.	Q	6	Q 1
5	Batch number	Optional: Year and week of production	2P	14	2P 401503180016
6	ID/serial number	Optional: Present-day serial number system, e.g. with safety products	51S	12	51S 678294
7	Variant number	Optional: Product variant number on the basis of standard products	30P	32	30P F971, 2*K183
...					

Further types of information and data identifiers are used by Beckhoff and serve internal processes.

Structure of the BIC

Example of composite information from positions 1 to 4 and with the above given example value on position 6. The data identifiers are highlighted in bold font:

1P072222**SBTN**k4p562d7**1K**EL1809 **Q**1 **51S**678294

Accordingly as DMC:



Fig. 17: Example DMC **1P**072222**SBTN**k4p562d7**1K**EL1809 **Q**1 **51S**678294

BTN

An important component of the BIC is the Beckhoff Traceability Number (BTN, position 2). The BTN is a unique serial number consisting of eight characters that will replace all other serial number systems at Beckhoff in the long term (e.g. batch designations on IO components, previous serial number range for safety products, etc.). The BTN will also be introduced step by step, so it may happen that the BTN is not yet coded in the BIC.

NOTE

This information has been carefully prepared. However, the procedure described is constantly being further developed. We reserve the right to revise and change procedures and documentation at any time and without prior notice. No claims for changes can be made from the information, illustrations and descriptions in this information.

6.2 Support and Service

Beckhoff and their partners around the world offer comprehensive support and service, making available fast and competent assistance with all questions related to Beckhoff products and system solutions.

Beckhoff's branch offices and representatives

Please contact your Beckhoff branch office or representative for local support and service on Beckhoff products!

The addresses of Beckhoff's branch offices and representatives round the world can be found on her internet pages: <https://www.beckhoff.com>

You will also find further documentation for Beckhoff components there.

Beckhoff Support

Support offers you comprehensive technical assistance, helping you not only with the application of individual Beckhoff products, but also with other, wide-ranging services:

- support
- design, programming and commissioning of complex automation systems
- and extensive training program for Beckhoff system components

Hotline: +49 5246 963 157
Fax: +49 5246 963 9157
e-mail: support@beckhoff.com

Beckhoff Service

The Beckhoff Service Center supports you in all matters of after-sales service:

- on-site service
- repair service
- spare parts service
- hotline service

Hotline: +49 5246 963 460
Fax: +49 5246 963 479
e-mail: service@beckhoff.com

Beckhoff Headquarters

Beckhoff Automation GmbH & Co. KG

Huelshorstweg 20
33415 Verl
Germany

Phone: +49 5246 963 0
Fax: +49 5246 963 198
e-mail: info@beckhoff.com
web: <https://www.beckhoff.com>

Table of figures

Fig. 1	KL5121	8
Fig. 2	Spring contacts of the Beckhoff I/O components	11
Fig. 3	Attaching on mounting rail.....	12
Fig. 4	Disassembling of terminal	13
Fig. 5	Power contact on left side	14
Fig. 6	Standard wiring	16
Fig. 7	Pluggable wiring.....	16
Fig. 8	High Density Terminals	17
Fig. 9	Connecting a cable on a terminal point.....	18
Fig. 10	KL5121 - Contact assignment and LEDs	20
Fig. 11	KS2000 configuration software	24
Fig. 12	Mapping for Lightbus Coupler - sample KL5121.....	26
Fig. 13	Mapping for Profibus Coupler - example for KL5121	27
Fig. 14	Mapping for Interbus Coupler - sample for KL5121	27
Fig. 15	Register mode control byte	37
Fig. 16	BIC as data matrix code (DMC, code scheme ECC200)	42
Fig. 17	Example DMC 1P072222SBTNk4p562d71KEL1809 Q1 51S678294	43

More Information:
www.beckhoff.com/KL5121

Beckhoff Automation GmbH & Co. KG
Hülshorstweg 20
33415 Verl
Germany
Phone: +49 5246 9630
info@beckhoff.com
www.beckhoff.com

