

Documentation | EN

# KL6021/KS6021

Serial Interface Terminals, RS485 (RS422)

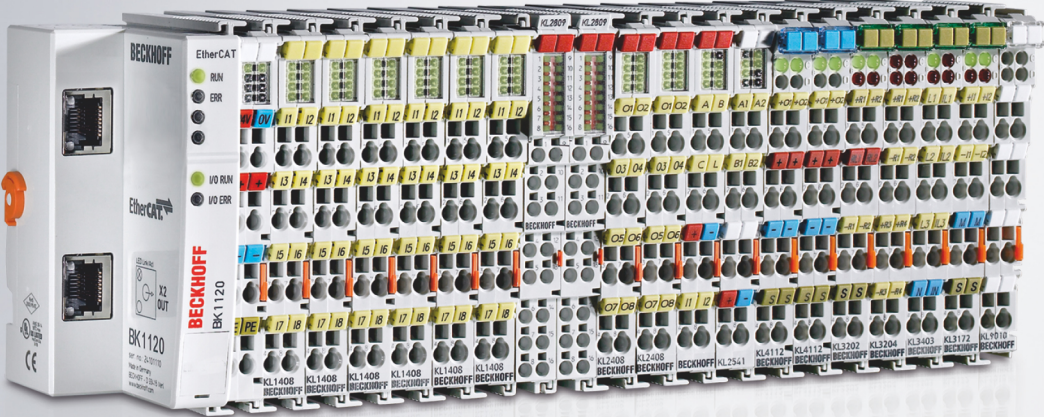



# Table of content

<b>1 Foreword</b> .....	<b>5</b>
1.1 Notes on the documentation .....	5
1.2 Safety instructions .....	6
1.3 Documentation Issue Status .....	7
<b>2 Product overview</b> .....	<b>8</b>
2.1 KL6021/KS6021 - Introduction .....	8
2.2 KL6021/KS6021 - Technical data .....	9
2.3 Basic Function Principles .....	10
<b>3 Mounting and wiring</b> .....	<b>11</b>
3.1 Instructions for ESD protection .....	11
3.2 Installation on mounting rails.....	12
3.3 Disposal .....	14
3.4 Installation instructions for enhanced mechanical load capacity.....	15
3.5 Connection .....	16
3.5.1 Connection system.....	16
3.5.2 Wiring.....	18
3.5.3 Shielding .....	19
3.6 ATEX - Special conditions (standard temperature range).....	20
3.7 Continuative documentation for ATEX and IECEx.....	21
<b>4 Configuration Software KS2000</b> .....	<b>22</b>
4.1 KS2000 - Introduction .....	22
<b>5 Access from the user program</b> .....	<b>24</b>
5.1 KL6021/KS6021 - Terminal configuration .....	24
5.2 Mapping in the Bus Coupler .....	26
5.2.1 Standard format .....	26
5.3 Register overview.....	28
5.4 Register description .....	28
5.5 Register communication KL6021 .....	32
5.6 Data exchange, function .....	34
5.7 Examples of Register Communication .....	36
5.7.1 Example 1: Reading the firmware version from register 9 .....	36
5.7.2 Example 2: Writing to an user register .....	36
<b>6 Appendix</b> .....	<b>40</b>
6.1 Beckhoff Identification Code (BIC) .....	40
6.2 Support and Service.....	42



# 1 Foreword

## 1.1 Notes on the documentation

### Intended audience

This description is only intended for the use of trained specialists in control and automation engineering who are familiar with the applicable national standards.

It is essential that the documentation and the following notes and explanations are followed when installing and commissioning these components.

It is the duty of the technical personnel to use the documentation published at the respective time of each installation and commissioning.

The responsible staff must ensure that the application or use of the products described satisfy all the requirements for safety, including all the relevant laws, regulations, guidelines and standards.

### Disclaimer

The documentation has been prepared with care. The products described are, however, constantly under development.

We reserve the right to revise and change the documentation at any time and without prior announcement.

No claims for the modification of products that have already been supplied may be made on the basis of the data, diagrams and descriptions in this documentation.

### Trademarks

Beckhoff®, TwinCAT®, TwinCAT/BSD®, TC/BSD®, EtherCAT®, EtherCAT G®, EtherCAT G10®, EtherCAT P®, Safety over EtherCAT®, TwinSAFE®, XFC®, XTS® and XPlanar® are registered trademarks of and licensed by Beckhoff Automation GmbH. Other designations used in this publication may be trademarks whose use by third parties for their own purposes could violate the rights of the owners.

### Patent Pending

The EtherCAT Technology is covered, including but not limited to the following patent applications and patents: EP1590927, EP1789857, EP1456722, EP2137893, DE102015105702 with corresponding applications or registrations in various other countries.

The logo for EtherCAT, featuring the word "EtherCAT" in a bold, black, sans-serif font. A red arrow points from the top of the "A" towards the right, ending above the "T". A registered trademark symbol (®) is located to the right of the "T".

EtherCAT® is registered trademark and patented technology, licensed by Beckhoff Automation GmbH, Germany.

### Copyright

© Beckhoff Automation GmbH & Co. KG, Germany.

The reproduction, distribution and utilization of this document as well as the communication of its contents to others without express authorization are prohibited.

Offenders will be held liable for the payment of damages. All rights reserved in the event of the grant of a patent, utility model or design.

## 1.2 Safety instructions

### Safety regulations

Please note the following safety instructions and explanations!  
Product-specific safety instructions can be found on following pages or in the areas mounting, wiring, commissioning etc.

### Exclusion of liability

All the components are supplied in particular hardware and software configurations appropriate for the application. Modifications to hardware or software configurations other than those described in the documentation are not permitted, and nullify the liability of Beckhoff Automation GmbH & Co. KG.

### Personnel qualification

This description is only intended for trained specialists in control, automation and drive engineering who are familiar with the applicable national standards.

### Description of instructions

In this documentation the following instructions are used.  
These instructions must be read carefully and followed without fail!

#### **DANGER**

##### **Serious risk of injury!**

Failure to follow this safety instruction directly endangers the life and health of persons.

#### **WARNING**

##### **Risk of injury!**

Failure to follow this safety instruction endangers the life and health of persons.

#### **CAUTION**

##### **Personal injuries!**

Failure to follow this safety instruction can lead to injuries to persons.

#### **NOTE**

##### **Damage to environment/equipment or data loss**

Failure to follow this instruction can lead to environmental damage, equipment damage or data loss.



##### **Tip or pointer**

This symbol indicates information that contributes to better understanding.

### 1.3 Documentation Issue Status

Version	Comment
3.1.0	<ul style="list-style-type: none"> <li>• Chapter <i>Technical data</i> updated</li> <li>• Ex markings added to technical data</li> <li>• Chapter <i>Beckhoff Identification Code (BIC)</i> updated</li> <li>• Chapter <i>Disposal</i> added</li> <li>• Document structure updated</li> <li>• New title page</li> </ul>
3.0.0	<ul style="list-style-type: none"> <li>• Migration</li> <li>• Structure update</li> <li>• Chapter <i>Beckhoff Identification Code (BIC)</i> added</li> </ul>

#### Firmware and hardware versions

Documentation, Version	KL6021, KS6021	
	Firmware	Firmware
3.1.0	3C	10
3.0.0	3C	09

The firmware and hardware versions (delivery state) of the terminal can be found in the serial number printed on the side.

#### Syntax of the serial number

Structure of the serial number: WW YY FF HH

- WW - week of production (calendar week)
- YY - year of production
- FF - firmware version
- HH - hardware version

Example with serial number 35 04 1B 01:

- 35 - week of production 35
- 04 - year of production 2004
- 1B - firmware version 1B
- 01 - hardware version 01

## 2 Product overview

### 2.1 KL6021/KS6021 - Introduction

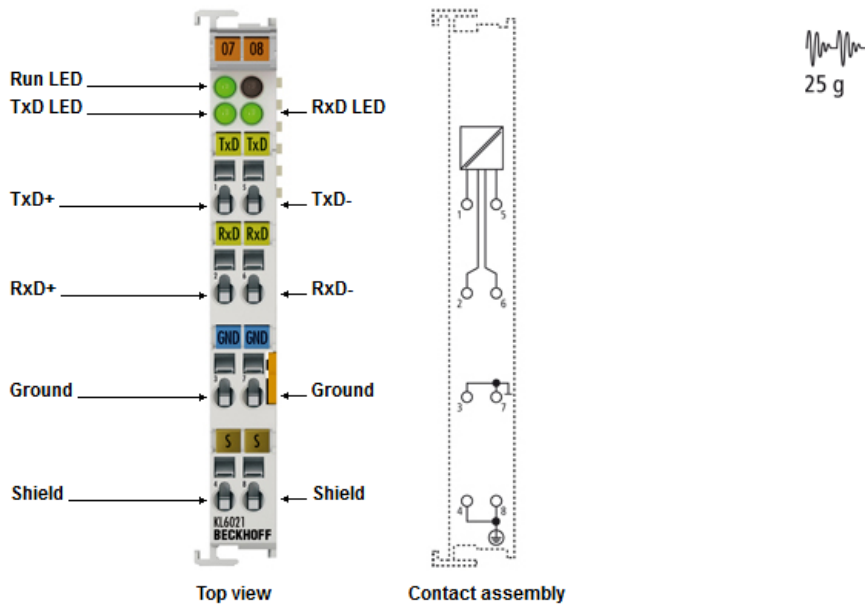

Fig. 1: KL6021

#### Serial interface RS422/RS485

The KL6021/KS6021 serial interface allows devices with RS422 or RS485 interface to be connected. The device connected to the terminal communicates with the automation device via the Bus Coupler. The active communication channel operates independently of the higher-level bus system in full or half duplex mode at up to 19,200 baud. The differential signal transmission according to RS422 guarantees high immunity to interference through electrically isolated signals.



## 2.2 KL6021/KS6021 - Technical data

Technical data	KL6021, KS6021
Technology	RS422/RS485
Data transfer channels	TxD and RxD, full duplex (half duplex)
Data transfer rate	1200...19200 baud, default: 9600 baud, 8 data bits, no parity and one stop bit are preset (max. 19200 baud)
Bit transfer	with differential signal
Line impedance	120 Ω
Cable length	approx. 1000 m twisted pair
Power supply	via the K-bus
Current consumption from K-bus	typ. 65 mA
Electrical isolation	500 V (K-bus/signal voltage)
Data buffer	128 bytes receive buffer, 16 bytes transmit buffer
Bit width in process image	input/output: 3 x 8 bits user data, 1 x 8 bits control/status (up to 5 x 8 bits user data are possible)
Configuration	no address setting, configuration via bus coupler or controller
Weight	approx. 60 g
Permissible ambient temperature range during operation	0°C ... +55°C
Permissible ambient temperature range during storage	-25 °C ... +85 °C
Permissible relative humidity	95% no condensation
<a href="#">Mounting</a> [ <a href="#">▶ 12</a> ]	on 35 mm mounting rail according to EN 60715
Pluggable wiring	for all KSxxxx terminals
Enhanced mechanical load capacity	yes, see <a href="#">Installation instructions</a> [ <a href="#">▶ 15</a> ] for enhanced mechanical load capacity
Vibration / shock resistance	conforms to EN 60068-2-6 / EN 60068-2-27
EMC immunity / emission	conforms to EN 61000-6-2 / EN 61000-6-4
Protection class	IP20
Installation position	variable
Approvals/markings*	CE, UKCA, cULus, EAC, ATEX [ <a href="#">▶ 20</a> ]

\*) Real applicable approvals/markings see type plate on the side (product marking).

### Ex marking

Standard	Marking
ATEX	II 3 G Ex nA IIC T4 Gc

## 2.3 Basic Function Principles

The KL6021 serial interface terminal enables the connection of devices with RS485 interface. Data can be exchanged with the controller in full/half duplex mode, independent of the higher-level bus system. The receive buffer has 128 bytes, the transmit buffer 16 bytes. The data transfer between terminal and controller is handled via a handshake in the status and control byte. The factory setting of the terminal is 9600 baud, 8 data bits, 1 stop bit, no parity, full duplex mode.

### LED display

The Run LED indicates the operating state of the terminal.

- On - normal operation
- Off - Watchdog timer overflow has occurred. If no process data is transmitted from the Bus Coupler for 100 ms, the green LED goes out.
- The TxD and RxD LEDs indicate the states of the signal lines.

### Alternative output format for process data

In the alternative output format, 4 or 5 bytes are mapped in the Bus Coupler (3 bytes for data and 1 or 2 control/status byte(s)). The KL6021 is delivered in the alternative format. The mapping of the terminal in the alternative format is described in more detail in the chapter Terminal configuration.

### Standard output format for process data

In the standard output format, 4 bytes are mapped in the Bus Coupler (3 bytes for user data and 1 control/status byte). By changing the parameters of the KL6021, up to 5 bytes of user data can be transferred.

### Reference

The chapter on "Access from the user program" contains an overview of possible mapping configurations, depending on the configurable parameters.

### Connection for RS485 transfer

In RS485 mode, data is transmitted in half duplex mode. A bus structure can be created in this operation mode.



Fig. 2: Connection for RS485 transfer

### Connection for RS422 transfer

In RS422 mode, data is transmitted in full duplex mode. Only peer-to-peer connections can be established.



Fig. 3: Connection for RS422 transfer

## 3 Mounting and wiring

### 3.1 Instructions for ESD protection

#### NOTE

##### **Destruction of the devices by electrostatic discharge possible!**

The devices contain components at risk from electrostatic discharge caused by improper handling.

- Please ensure you are electrostatically discharged and avoid touching the contacts of the device directly.
- Avoid contact with highly insulating materials (synthetic fibers, plastic film etc.).
- Surroundings (working place, packaging and personnel) should be grounded probably, when handling with the devices.
- Each assembly must be terminated at the right hand end with a KL9010 bus end terminal, to ensure the protection class and ESD protection.

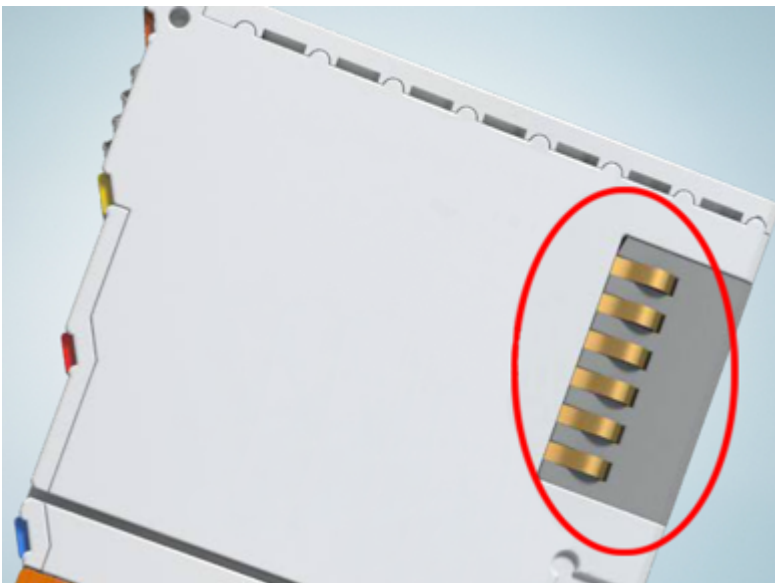

Fig. 4: Spring contacts of the Beckhoff I/O components

## 3.2 Installation on mounting rails

### ⚠ WARNING

#### Risk of electric shock and damage of device!

Bring the bus terminal system into a safe, powered down state before starting installation, disassembly or wiring of the bus terminals!

#### Assembly

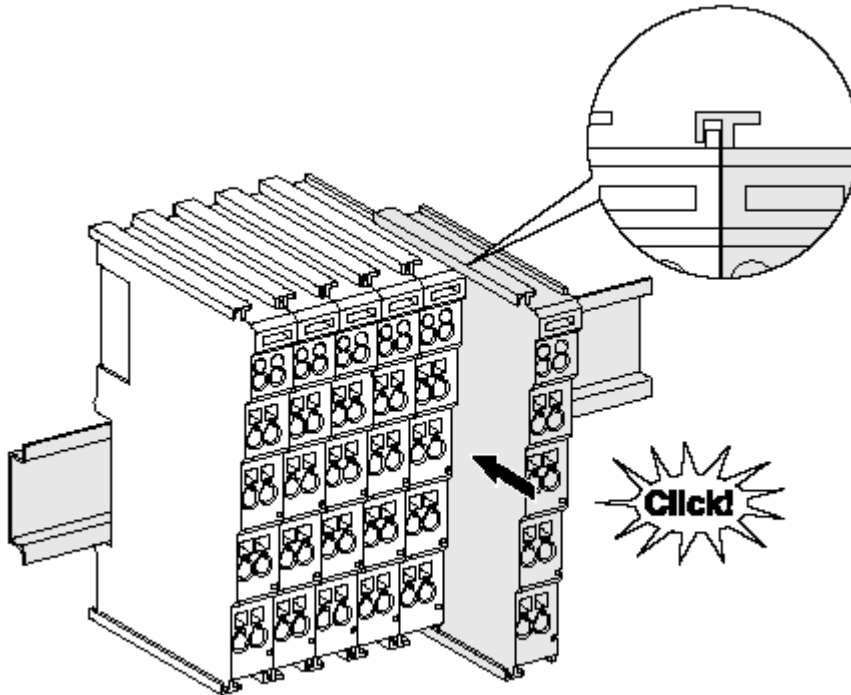

Fig. 5: Attaching on mounting rail

The bus coupler and bus terminals are attached to commercially available 35 mm mounting rails (DIN rails according to EN 60715) by applying slight pressure:

1. First attach the fieldbus coupler to the mounting rail.
2. The bus terminals are now attached on the right-hand side of the fieldbus coupler. Join the components with tongue and groove and push the terminals against the mounting rail, until the lock clicks onto the mounting rail.

If the terminals are clipped onto the mounting rail first and then pushed together without tongue and groove, the connection will not be operational! When correctly assembled, no significant gap should be visible between the housings.

#### **i** Fixing of mounting rails

The locking mechanism of the terminals and couplers extends to the profile of the mounting rail. At the installation, the locking mechanism of the components must not come into conflict with the fixing bolts of the mounting rail. To mount the mounting rails with a height of 7.5 mm under the terminals and couplers, you should use flat mounting connections (e.g. countersunk screws or blind rivets).

**Disassembly**

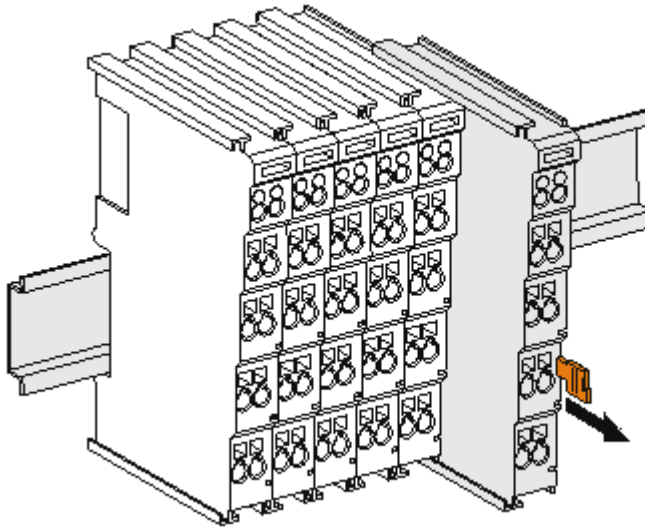

Fig. 6: Disassembling of terminal

Each terminal is secured by a lock on the mounting rail, which must be released for disassembly:

1. Pull the terminal by its orange-colored lugs approximately 1 cm away from the mounting rail. In doing so for this terminal the mounting rail lock is released automatically and you can pull the terminal out of the bus terminal block easily without excessive force.
2. Grasp the released terminal with thumb and index finger simultaneous at the upper and lower grooved housing surfaces and pull the terminal out of the bus terminal block.

**Connections within a bus terminal block**

The electric connections between the Bus Coupler and the Bus Terminals are automatically realized by joining the components:

- The six spring contacts of the K-Bus/E-Bus deal with the transfer of the data and the supply of the Bus Terminal electronics.
- The power contacts deal with the supply for the field electronics and thus represent a supply rail within the bus terminal block. The power contacts are supplied via terminals on the Bus Coupler (up to 24 V) or for higher voltages via power feed terminals.

**● Power Contacts**  
**i**

During the design of a bus terminal block, the pin assignment of the individual Bus Terminals must be taken account of, since some types (e.g. analog Bus Terminals or digital 4-channel Bus Terminals) do not or not fully loop through the power contacts. Power Feed Terminals (KL91xx, KL92xx or EL91xx, EL92xx) interrupt the power contacts and thus represent the start of a new supply rail.

**PE power contact**

The power contact labeled PE can be used as a protective earth. For safety reasons this contact mates first when plugging together, and can ground short-circuit currents of up to 125 A.

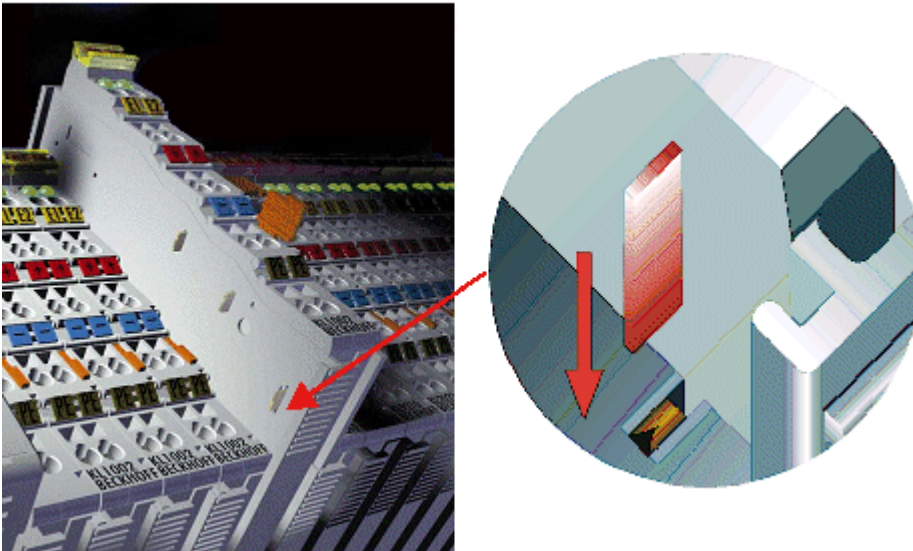

Fig. 7: Power contact on left side

**NOTE****Possible damage of the device**

Note that, for reasons of electromagnetic compatibility, the PE contacts are capacitatively coupled to the mounting rail. This may lead to incorrect results during insulation testing or to damage on the terminal (e.g. disruptive discharge to the PE line during insulation testing of a consumer with a nominal voltage of 230 V). For insulation testing, disconnect the PE supply line at the Bus Coupler or the Power Feed Terminal! In order to decouple further feed points for testing, these Power Feed Terminals can be released and pulled at least 10 mm from the group of terminals.

**⚠ WARNING****Risk of electric shock!**

The PE power contact must not be used for other potentials!

**3.3 Disposal**

Products marked with a crossed-out wheeled bin shall not be discarded with the normal waste stream. The device is considered as waste electrical and electronic equipment. The national regulations for the disposal of waste electrical and electronic equipment must be observed.

### 3.4 Installation instructions for enhanced mechanical load capacity

<b>⚠ WARNING</b>
<b>Risk of injury through electric shock and damage to the device!</b>
Bring the Bus Terminal system into a safe, de-energized state before starting mounting, disassembly or wiring of the Bus Terminals!

**Additional checks**

The terminals have undergone the following additional tests:

Verification	Explanation
Vibration	10 frequency runs in 3 axes
	6 Hz < f < 60 Hz displacement 0.35 mm, constant amplitude
	60.1 Hz < f < 500 Hz acceleration 5 g, constant amplitude
Shocks	1000 shocks in each direction, in 3 axes
	25 g, 6 ms

**Additional installation instructions**

For terminals with enhanced mechanical load capacity, the following additional installation instructions apply:

- The enhanced mechanical load capacity is valid for all permissible installation positions
- Use a mounting rail according to EN 60715 TH35-15
- Fix the terminal segment on both sides of the mounting rail with a mechanical fixture, e.g. an earth terminal or reinforced end clamp
- The maximum total extension of the terminal segment (without coupler) is:  
64 terminals (12 mm mounting with) or 32 terminals (24 mm mounting with)
- Avoid deformation, twisting, crushing and bending of the mounting rail during edging and installation of the rail
- The mounting points of the mounting rail must be set at 5 cm intervals
- Use countersunk head screws to fasten the mounting rail
- The free length between the strain relief and the wire connection should be kept as short as possible. A distance of approx. 10 cm should be maintained to the cable duct.

## 3.5 Connection

### 3.5.1 Connection system

#### ⚠ WARNING

#### Risk of electric shock and damage of device!

Bring the bus terminal system into a safe, powered down state before starting installation, disassembly or wiring of the bus terminals!

#### Overview

The bus terminal system offers different connection options for optimum adaptation to the respective application:

- The terminals of ELxxxx and KLxxxx series with standard wiring include electronics and connection level in a single enclosure.
- The terminals of ESxxxx and KSxxxx series feature a pluggable connection level and enable steady wiring while replacing.
- The High Density Terminals (HD Terminals) include electronics and connection level in a single enclosure and have advanced packaging density.

#### Standard wiring (ELxxxx / KLxxxx)



Fig. 8: Standard wiring

The terminals of ELxxxx and KLxxxx series have been tried and tested for years. They feature integrated screwless spring force technology for fast and simple assembly.

#### Pluggable wiring (ESxxxx / KSxxxx)



Fig. 9: Pluggable wiring

The terminals of ESxxxx and KSxxxx series feature a pluggable connection level. The assembly and wiring procedure is the same as for the ELxxxx and KLxxxx series. The pluggable connection level enables the complete wiring to be removed as a plug connector from the top of the housing for servicing. The lower section can be removed from the terminal block by pulling the unlocking tab. Insert the new component and plug in the connector with the wiring. This reduces the installation time and eliminates the risk of wires being mixed up.

The familiar dimensions of the terminal only had to be changed slightly. The new connector adds about 3 mm. The maximum height of the terminal remains unchanged.



A tab for strain relief of the cable simplifies assembly in many applications and prevents tangling of individual connection wires when the connector is removed.

Conductor cross sections between 0.08 mm<sup>2</sup> and 2.5 mm<sup>2</sup> can continue to be used with the proven spring force technology.

The overview and nomenclature of the product names for ESxxxx and KSxxxx series has been retained as known from ELxxxx and KLxxxx series.

### High Density Terminals (HD Terminals)



Fig. 10: High Density Terminals

The terminals from these series with 16 terminal points are distinguished by a particularly compact design, as the packaging density is twice as large as that of the standard 12 mm bus terminals. Massive conductors and conductors with a wire end sleeve can be inserted directly into the spring loaded terminal point without tools.

---

#### ● Wiring HD Terminals



The High Density Terminals of the ELx8xx and KLx8xx series doesn't support pluggable wiring.

---

### Ultrasonically “bonded” (ultrasonically welded) conductors

---

#### ● Ultrasonically “bonded” conductors



It is also possible to connect the Standard and High Density Terminals with ultrasonically “bonded” (ultrasonically welded) conductors. In this case, please note the tables concerning the wire-size width [► 18]!

---

### 3.5.2 Wiring

#### ⚠ WARNING

##### Risk of electric shock and damage of device!

Bring the bus terminal system into a safe, powered down state before starting installation, disassembly or wiring of the bus terminals!

#### Terminals for standard wiring ELxxxx/KLxxxx and for pluggable wiring ESxxxx/KSxxxx

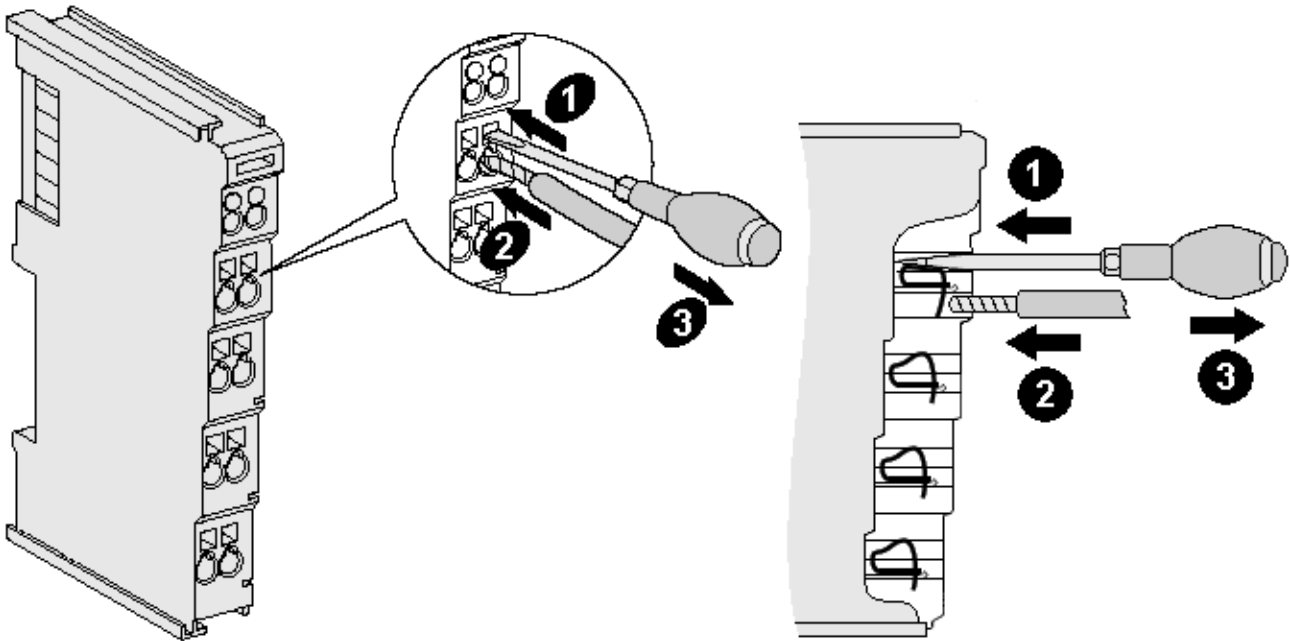

Fig. 11: Connecting a cable on a terminal point

Up to eight terminal points enable the connection of solid or finely stranded cables to the bus terminal. The terminal points are implemented in spring force technology. Connect the cables as follows:

1. Open a terminal point by pushing a screwdriver straight against the stop into the square opening above the terminal point. Do not turn the screwdriver or move it alternately (don't toggle).
2. The wire can now be inserted into the round terminal opening without any force.
3. The terminal point closes automatically when the pressure is released, holding the wire securely and permanently.

See the following table for the suitable wire size width.

Terminal housing	ELxxxx, KLxxxx	ESxxxx, KSxxxx
Wire size width (single core wires)	0.08 ... 2.5 mm <sup>2</sup>	0.08 ... 2.5 mm <sup>2</sup>
Wire size width (fine-wire conductors)	0.08 ... 2.5 mm <sup>2</sup>	0.08 ... 2.5 mm <sup>2</sup>
Wire size width (conductors with a wire end sleeve)	0.14 ... 1.5 mm <sup>2</sup>	0.14 ... 1.5 mm <sup>2</sup>
Wire stripping length	8 ... 9 mm	9 ... 10 mm

#### High Density Terminals (HD Terminals [[▶ 17](#)]) with 16 terminal points

The conductors of the HD Terminals are connected without tools for single-wire conductors using the direct plug-in technique, i.e. after stripping the wire is simply plugged into the terminal point. The cables are released, as usual, using the contact release with the aid of a screwdriver. See the following table for the suitable wire size width.

Terminal housing	High Density Housing
Wire size width (single core wires)	0.08 ... 1.5 mm <sup>2</sup>
Wire size width (fine-wire conductors)	0.25 ... 1.5 mm <sup>2</sup>
Wire size width (conductors with a wire end sleeve)	0.14 ... 0.75 mm <sup>2</sup>
Wire size width (ultrasonically "bonded" conductors)	only 1.5 mm <sup>2</sup> (see notice [▶ 17])
Wire stripping length	8 ... 9 mm

### 3.5.3 Shielding



#### Shielding

Encoder, analog sensors and actors should always be connected with shielded, twisted paired wires.

## 3.6 ATEX - Special conditions (standard temperature range)

### ⚠ WARNING

**Observe the special conditions for the intended use of Beckhoff fieldbus components with standard temperature range in potentially explosive areas (directive 2014/34/EU)!**

- The certified components are to be installed in a suitable housing that guarantees a protection class of at least IP54 in accordance with EN 60079-15! The environmental conditions during use are thereby to be taken into account!
- For dust (only the fieldbus components of certificate no. KEMA 10ATEX0075 X Issue 9): The equipment shall be installed in a suitable enclosure providing a degree of protection of IP54 according to EN 60079-31 for group IIIA or IIIB and IP6X for group IIIC, taking into account the environmental conditions under which the equipment is used!
- If the temperatures during rated operation are higher than 70°C at the feed-in points of cables, lines or pipes, or higher than 80°C at the wire branching points, then cables must be selected whose temperature data correspond to the actual measured temperature values!
- Observe the permissible ambient temperature range of 0 to 55°C for the use of Beckhoff fieldbus components standard temperature range in potentially explosive areas!
- Measures must be taken to protect against the rated operating voltage being exceeded by more than 40% due to short-term interference voltages!
- The individual terminals may only be unplugged or removed from the Bus Terminal system if the supply voltage has been switched off or if a non-explosive atmosphere is ensured!
- The connections of the certified components may only be connected or disconnected if the supply voltage has been switched off or if a non-explosive atmosphere is ensured!
- The fuses of the KL92xx/EL92xx power feed terminals may only be exchanged if the supply voltage has been switched off or if a non-explosive atmosphere is ensured!
- Address selectors and ID switches may only be adjusted if the supply voltage has been switched off or if a non-explosive atmosphere is ensured!

### Standards

The fundamental health and safety requirements are fulfilled by compliance with the following standards:

- EN 60079-0:2012+A11:2013
- EN 60079-15:2010
- EN 60079-31:2013 (only for certificate no. KEMA 10ATEX0075 X Issue 9)

### Marking

The Beckhoff fieldbus components with standard temperature range certified according to the ATEX directive for potentially explosive areas bear one of the following markings:



**II 3G KEMA 10ATEX0075 X Ex nA IIC T4 Gc Ta: 0 ... +55°C**

II 3D KEMA 10ATEX0075 X Ex tc IIIC T135°C Dc Ta: 0 ... +55°C  
(only for fieldbus components of certificate no. KEMA 10ATEX0075 X Issue 9)

or



**II 3G KEMA 10ATEX0075 X Ex nA nC IIC T4 Gc Ta: 0 ... +55°C**

II 3D KEMA 10ATEX0075 X Ex tc IIIC T135°C Dc Ta: 0 ... +55°C  
(only for fieldbus components of certificate no. KEMA 10ATEX0075 X Issue 9)

### 3.7 Continulative documentation for ATEX and IECEx

**NOTE****Continulative documentation about explosion protection according to ATEX and IECEx**

Pay also attention to the continuative documentation

**Ex. Protection for Terminal Systems**

Notes on the use of the Beckhoff terminal systems in hazardous areas according to ATEX and IECEx,

that is available for [download](#) within the download area of your product on the Beckhoff homepage [www.beckhoff.com](http://www.beckhoff.com)!

## 4 Configuration Software KS2000

### 4.1 KS2000 - Introduction

The KS2000 configuration software permits configuration, commissioning and parameterization of bus couplers, of the affiliated bus terminals and of Fieldbus Box Modules. The connection between bus coupler / Fieldbus Box Module and the PC is established by means of the serial configuration cable or the fieldbus.



Fig. 12: KS2000 configuration software

#### Configuration

You can configure the Fieldbus stations with the Configuration Software KS2000 offline. That means, setting up a terminal station with all settings on the couplers and terminals resp. the Fieldbus Box Modules can be prepared before the commissioning phase. Later on, this configuration can be transferred to the terminal station in the commissioning phase by means of a download. For documentation purposes, you are provided with the breakdown of the terminal station, a parts list of modules used and a list of the parameters you have modified. After an upload, existing fieldbus stations are at your disposal for further editing.

#### Parameterization

KS2000 offers simple access to the parameters of a fieldbus station: specific high-level dialogs are available for all bus couplers, all intelligent bus terminals and Fieldbus Box modules with the aid of which settings can be modified easily. Alternatively, you have full access to all internal registers of the bus couplers and intelligent terminals. Refer to the register description for the meanings of the registers.

## Commissioning

The KS2000 software facilitates commissioning of machine components or their fieldbus stations: Configured settings can be transferred to the fieldbus modules by means of a download. After a *login* to the terminal station, it is possible to define settings in couplers, terminals and Fieldbus Box modules directly *online*. The same high-level dialogs and register access are available for this purpose as in the configuration phase.

The KS2000 offers access to the process images of the bus couplers and Fieldbus Box modules.

- Thus, the coupler's input and output images can be observed by monitoring.
- Process values can be specified in the output image for commissioning of the output modules.

All possibilities in the *online mode* can be used in parallel with the actual fieldbus mode of the terminal station. The fieldbus protocol always has the higher priority in this case.

## 5 Access from the user program

### 5.1 KL6021/KS6021 - Terminal configuration

The terminal can be configured and parameterized via the internal register structure.

Each terminal channel is mapped in the Bus Coupler. Depending on the type of the Bus Coupler and the mapping configuration (e. g. Motorola/Intel format, word alignment etc.) the terminal data are mapped in different ways to the Bus Coupler memory.

To parameterize a terminal, it is necessary to map the control/status byte.

#### BK2000 Lightbus Coupler

In the BK2000 Lightbus Coupler, the control/status byte is mapped in addition to the data bytes. This is always in the low byte on the offset address of the terminal channel. With the KL6021/KS6021, the control/status byte is used exclusively in register mode. The Ser. control/status byte is used for the handshake protocol.

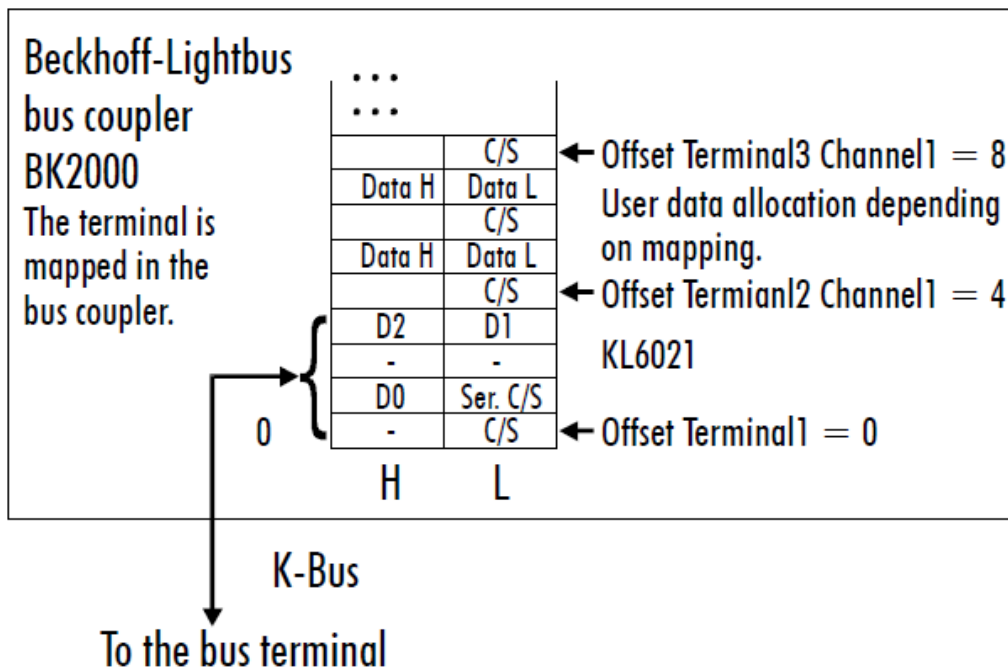

Fig. 13: Mapping for Lightbus Coupler, example: KL6021

#### BK3000 PROFIBUS Coupler

With the BK3000 Profibus Coupler, the mapping of the KL6021/KS6021 in the Bus Coupler is set in the master configuration software. The KL6021/KS6021 is delivered in the alternative format. To set the standard format and a different user data length, please refer to registers 34 and 35. The figure shows the mapping for 4 bytes of input data and 4 bytes of output data.



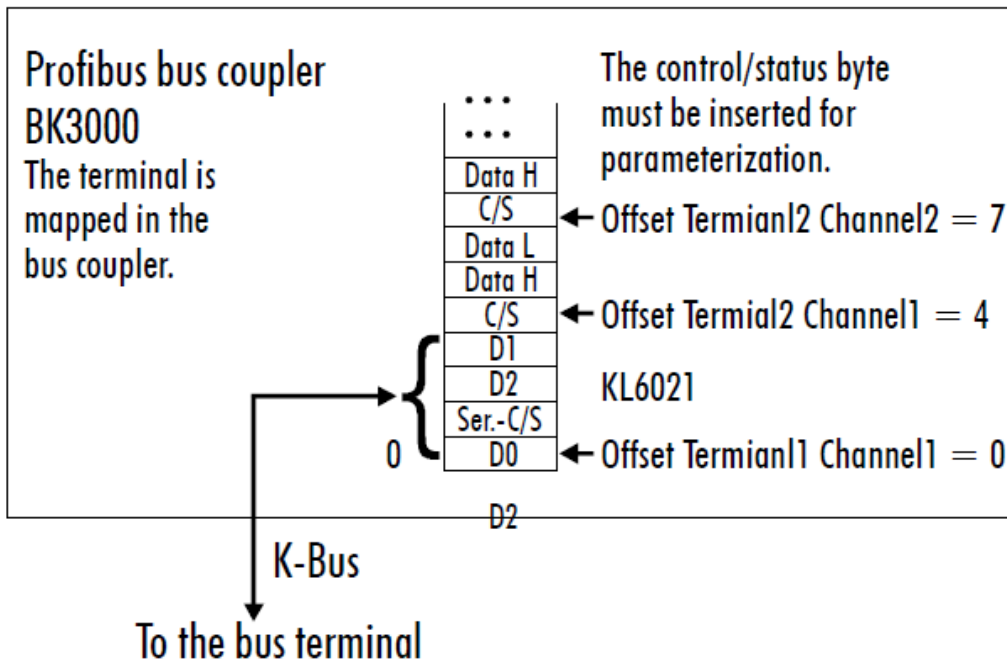

Fig. 14: Mapping for Profibus Coupler - example for KL6021

**BK4000 Interbus Coupler**

By default, the BK4000 Interbus Coupler maps the KL6021/KS6021 with 4 bytes of input data and 4 bytes of output data. Parameterization via the fieldbus is not possible. The KS2000 software is required if the terminal is to be reparameterized.

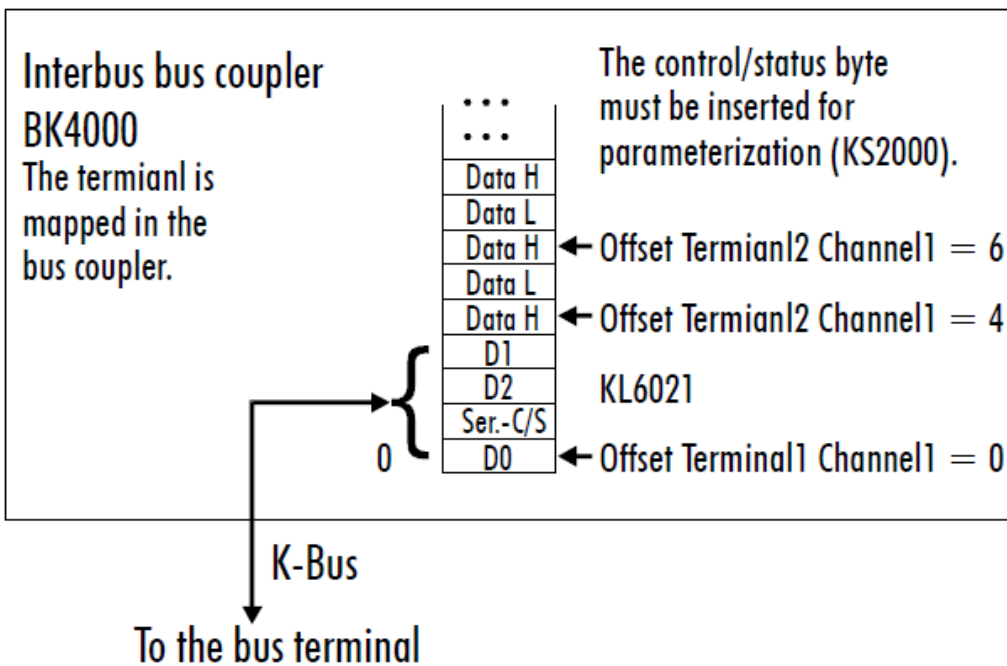

Fig. 15: Mapping for Interbus Coupler - example for KL6021

**Other Bus Couplers and further information**

Further information about the mapping configuration of Bus Couplers can be found in the Appendix of the respective Bus Coupler manual under *Master configuration*.

The chapter on Mapping in the Bus Coupler [▶ 26] contains an overview of possible mapping configurations, depending on the configurable parameters.

## **i** Parameterization with KS2000

The KS2000 configuration software can be used for parameterizations via the serial interface of the Bus Coupler, independent of the fieldbus system.

## 5.2 Mapping in the Bus Coupler

As already described in the *Terminal Configuration* section, each Bus Terminal is mapped in the Bus Coupler. This mapping is usually done with the default setting in the Bus Coupler / Bus Terminal. The KS2000 configuration software or a master configuration software (e.g. ComProfibus or TwinCAT System Manager) can be used to change this default setting.

If the terminals are fully evaluated, they occupy memory space in the input and output process image.

The following tables provide information about how the terminals map themselves in the Bus Coupler, depending on the parameters set.

### 5.2.1 Standard format

In the standard format, the KL6021 is mapped by default with 4 bytes of input and output data (adjustable: 2 to 6 bytes via R35).

Note: In the standard format, the Control/Status byte is used for register and process data communication.

Conditions	I/O offset	High byte	Low byte
Complete evaluation: any	3		
Motorola format: any	2	D4(opt.)	D3(opt.)
Word alignment: any	1	D2(opt.)	D1(opt.)
	0	D0	CB/SB

### Alternative format

In the alternatives format, the KL6021 is mapped with 4/6 bytes of input data and 4/6 bytes of output data. The KL6021 is delivered in the alternative format.

Note: In the alternative format, the Control/Status byte is only used for register communication, while the Ser. Control/Status byte is only used for the data handshake.

### Default for: CANopen, CANCEL, DeviceNET, ControlNet, RS232 and RS485

Conditions	I/O offset	High byte	Low byte
Full evaluation: no	3		
Motorola format: no	2		
Word alignment: no	1	D2	D1
	0	D0	Ser-CB/SB

### Default for: PROFIBUS and Interbus

Conditions	I/O offset	High byte	Low byte
Full evaluation: no	3		
Motorola format: yes	2		
Word alignment: no	1	D1	D2
	0	Ser-CB/SB	D0

Conditions	I/O offset	High byte	Low byte
Full evaluation: yes	3		
Motorola format: no	2	D2	D1
Word alignment: no	1	-	D0
	0	Ser-CB/SB	CB/SB

Conditions	I/O offset	High byte	Low byte
Full evaluation: yes	3		
Motorola format: yes	2	D1	D2
Word alignment: no	1	-	Ser-CB/SB
	0	D0	CB/SB

**Default for: Lightbus and Bus Terminal Controller (BCxxxx)**

Conditions	I/O offset	High byte	Low byte
Full evaluation: yes	3	D2	D1
Motorola format: no	2	-	-
Word alignment: yes	1	D0	Ser-CB/SB
	0	-	CB/SB

Conditions	I/O offset	High byte	Low byte
Full evaluation: yes	3	D1	D2
Motorola format: yes	2	-	-
Word alignment: yes	1	Ser-CB/SB	D0
	0	-	CB/SB

**Key**

- Complete evaluation            The terminal is mapped with control and status byte.
- Motorola format                Motorola or Intel format can be set.
- Word alignment                The terminal is positioned on a word limit in the Bus Coupler.
- CB                                Control byte (appears in the process image of the outputs).
- SB                                Status byte (appears in the process image of the inputs).
- Ser. CB                         Control byte for the handshake (appears in the process image of the outputs).
- Ser. SB                         Status byte for the handshake (appears in the process image of the inputs).
- D0-D4                         Data byte 0 - 4
- "-"                                This byte is not used or occupied by the terminal.

## 5.3 Register overview

Address	Name	Default value	R/W	Storage medium
R0	Number of data bytes in the send buffer	variable	R	RAM
R1	Number of data bytes in the receive buffer	variable	R	RAM
R2...R5	reserved	0x0000	R	
R6	Diagnostic register	variable	R	RAM
R7	Command register not used	0x0000	R	
R8	Terminal type	6021	R	ROM
R9	Firmware version	0x????	R	ROM
R10	Multiplex shift register	0x0218	R	ROM
R11	Signal channels	0x0130	R	ROM
R12	Minimum data length	0x3030	R	ROM
R13	Data structure	0x0000	R	ROM
R14	reserved	0x0000	R	
R15	Alignment register	variable	R/W	RAM
R16	Hardware version number	0x????	R/W	SEEROM
R17	reserved	0x0000	R/W	SEEROM
R18	"Buffer full" message	0x0080	R/W	SEEROM
R19...R30	reserved	0x0000	R/W	SEEROM
R31	Code word register	variable	R/W	RAM
R32	Baud rate	0x0006	R/W	SEEROM
R33	Data Frame	0x0003	R/W	SEEROM
R34	Feature register	0x0002	R/W	SEEROM
R35	Number of data bytes sent to the Bus Coupler	0x0003	R/W	SEEROM
R36...R47	reserved	0x0000	R/W	SEEROM

## 5.4 Register description

The registers can be read or written via the register communication. They are used for the parameterization of the terminal.

### General description of registers

Complex terminals that possess a processor are able to exchange data bi-directionally with the higher-level controller. These terminals are referred to below as intelligent Bus Terminals. These include the analog inputs (0 to 10 V, -10 to 10 V, 0 to 20 mA, 4 to 20 mA), the analog outputs (0 to 10 V, -10 to 10 V, 0 to 20 mA, 4 to 20 mA), serial interface terminals (RS485, RS232, TTY, data exchange terminals), counter terminals, encoder interfaces, SSI interfaces, PWM terminals and all other parameterizable modules.

The main features of the internal data structure are the same for all the intelligent terminals. This data area is organized as words, and includes 64 memory locations. The important data and parameters of the terminal can be read and set through this structure. It is also possible for functions to be called by means of corresponding parameters. Each logical channel in an intelligent terminal has such a structure (so a 4-channel analog terminal has 4 sets of registers).

This structure is divided into the following areas:

Range	Register number
Process variables	0 to 7
Type register	8 to 15
Manufacturer parameters	16 to 30
User parameters	31 to 47
Extended user area	48 to 63

**R0 to R7: Registers in the internal RAM of the terminal**

The process variables can be used in addition to the actual process image. Their function is specific to the terminal.

- **R0 to R5: The function of these registers depends on the type of terminal.**
- **R0: Number of data bytes in the transmission FIFO**  
The low byte contains the number of data in the transmission FIFO. The high byte is not used.
- **R1: Number of data bytes in the receive FIFO**  
The low byte contains the number of data in the receive FIFO. The high byte is not used.
- **R2 to R5: no function**
- **R6: Diagnostic register**  
The diagnostic register can contain additional diagnostic information. Parity errors, for instance, that occur in serial interface terminals during data transmission are indicated here.
- **R6: Diagnostic register**  
High byte: not used  
Low byte: Status of the receive channel (Bit 0 - 7)

Bit no.		Meaning
Bit 0	1	The receive buffer has overflowed, incoming data is lost.
Bit 1	1	A parity error has occurred.
Bit 2	1	A framing error has occurred.
Bit 3	1	An overrun error has occurred.
Bit 4	1	Buffer is full
Bit 5 - 15	-	not used – do not change!

- **R7: Command register**  
High-Byte\_Write = function parameter  
Low-Byte\_Write = function number  
High-Byte\_Read = function result  
Low-Byte\_Read = function number

**R8 to R15: Registers in the internal ROM of the terminal**

The type and system parameters are hard programmed by the manufacturer, and the user can read them but cannot change them.

- **R8: Terminal type**  
The terminal type in register R8 is needed to identify the terminal.
- **R9: Software version (X.y)**  
The software version can be read as a string of ASCII characters.
- **R10: Data length**  
R10 contains the number of multiplexed shift registers and their length in bits.  
The Bus Coupler sees this structure.
- **R11: Signal channels**  
Related to R10, this contains the number of channels that are logically present. Thus for example a shift register that is physically present can perfectly well consist of several signal channels.

- **R12: Minimum data length**

The particular byte contains the minimum data length for a channel that is to be transferred. If the MSB is set, the control and status byte is not necessarily required for the terminal function and is not transferred to the control, if the Bus Coupler is configured accordingly.

- **R13: Data type register**

Data type register	Meaning
0x00	Terminal with no valid data type
0x01	Byte array
0x02	Structure 1 byte n bytes
0x03	Word array
0x04	Structure 1 byte n words
0x05	Double word array
0x06	Structure 1 byte n double words
0x07	Structure 1 byte 1 double word
0x08	Structure 1 byte 1 double word
0x11	Byte array with variable logical channel length
0x12	Structure 1 byte n bytes with variable logical channel length (e.g. 60xx)
0x13	Word array with variable logical channel length
0x14	Structure 1 byte n words with variable logical channel length
0x15	Double word array with variable logical channel length
0x16	Structure 1 byte n double words with variable logical channel length

- **R14: reserved**

- **R15: Alignment bits (RAM)**

The alignment bits are used to place the analog terminal in the Bus Coupler on a byte boundary.

### R16 to R30: Manufacturer parameter area (SEEPROM)

The manufacturer parameters are specific for each type of terminal. They are programmed by the manufacturer, but can also be modified by the controller. The manufacturer parameters are stored in a serial EEPROM in the terminal, and are retained in the event of voltage drop-out.

These registers can only be altered after a code word has been set in R31 [► 30].

- **R18: Buffer size**

[0x0080]

Register R18 specifies the quantity of data in the receive FIFO above which the BUF\_F bit in the status byte is to be set.

Low byte: when this value is reached, BUF\_F is set in the status

High byte: not used

### R31 to R47: User parameter area (SEEPROM)

The user parameters are specific for each type of terminal. They can be modified by the programmer. The user parameters are stored in a serial EEPROM in the terminal, and are retained in the event of voltage drop-out. The user area is write-protected by a code word.

- **R31: Code word register in RAM**

**I** The code word **0x1235** must be entered here so that parameters in the user area can be modified. If any other value is entered into this register, the write-protection is active. When write protection is not active, the code word is returned when the register is read. If the write protection is active, the register contains a zero value.

- **R32: Feature register**

This register specifies the operation modes of the terminal. Thus, for instance, a user-specific scaling can be enabled for the analog I/Os.

The default values are shown in square brackets.

- **R32: Baud rate**  
[0x0006]

The default values are shown in square brackets.

Bit no.		Baud rate
<b>Bit 2, Bit 1, Bit 0</b>		
	011	1200 baud
	100	2400 baud
	101	4800 baud
	110	9600 baud [110]
	111	19200 baud
<b>Bit 3 - 15</b>	-	not used – do not change!

Furthermore, the baud rate can be set according to the following equation:

$$\text{Baud rate} = 4 \text{ MHz} / (16 * (\text{HB} + 1))$$

It is necessary for 0xFF to be written into the low byte here, while the high byte (HB) provides the operator.

- **R33 - R47**  
Registers that depend on the terminal type.
- **R33: Data Frame**  
[0x0003]  
This register is used to set the data frame.

Bit no.		Baud rate
<b>Bit 2, Bit 1, Bit 0</b>		
	0 0 1	7 data bits, even parity
	0 1 0	7 data bits, odd parity
	0 1 1	8 data bits, no parity [0 1 1]
	1 0 0	8 data bits, even parity
	1 0 1	8 data bits, odd parity
<b>Bit 3</b>	0/1	0: 1 stop bit [0] 1: 2 stop bits
<b>Bit 4 - 15</b>	-	not used – do not change!

- **R34: Feature register**  
[0x0003]  
The feature register specifies the operating modes of the terminal.

Feature bit no.		Description of the operation mode
<b>Bit 0</b>	0/1	1 half duplex: Reception of data sent by the terminal is suppressed. 0 full duplex: Data transmission is monitored in RS485 mode. [0]
<b>Bit 1</b>	0/1	0: Standard output format 1: Alternative output format [1]
<b>Bit 2</b>	1	The status byte is copied from the terminal into the shift registers of the K-bus one cycle later than the higher data bytes. This reduces the rate of data transmission to the controller. [0]
<b>Bit 3</b>	1	The XON/XOFF protocol is supported by the terminal when data is sent, i.e. the terminal sends the data transferred by the controller until it receives the XOFF character (DC3==0x13) from the partner device. Once this has occurred, transmission is halted until the XON character (DC1==0x11) is received. [0]
<b>Bit 4</b>	1	The XON/XOFF protocol is supported by the terminal when data is received. The terminal sends the control character XOFF when the terminal buffer contains 118 characters. XON is sent if XOFF was sent previously and the value falls below the lower buffer limit of 18 bytes. [0]
<b>Bit 5</b>	0/1	0: The terminal is used in a bus structure according to the RS485 standard. [0] 1: The terminal is used as a point-to-point connection (RS422), which means that the controller no longer switches the data line to high impedance.
<b>Bit 6</b>	1	Continuous sending of data from the FIFO. The send buffer is filled (up to 16 bytes) by the controller. The filled buffer content is transmitted with a rising edge in Control Byte 3. The terminal acknowledges the data transfer to the controller by setting the Status Byte 2 bit. Status Byte 2 is reset with Control Byte 3.
<b>Bit 7-15</b>	-	not used – do not change!

### ● Note on bit 6



This feature is available for all terminals with software version 3x or higher. The version information can be found on the right-hand side of the terminal in the serial number: xxxx3xxx  
Example: 52983A2A = software version 3A

- **R35: Number of data bytes mapped in the Bus Coupler**  
[0x0003]

Low byte: Number of data bytes transferred in the Bus Coupler and to the controller. Between 1 and 5 data bytes can be transferred. If more than 3 bytes of user data are to be transferred, the new number of bytes must be entered in this register.

High byte = not used

- **R47 - R63**

Extended registers with additional functions.

## 5.5 Register communication KL6021

### Register access via process data exchange

- **Bit 7=1: Register mode**

If bit 7 of the control byte is set, the first two bytes of the user data are not used for process data exchange but written into the register set of the terminal or read from it.

- **Bit 6=0: read, bit 6=1: write**

Bit 6 of the control bytes is used to specify whether a register should be read or written.

- **Bit 6=0:** A register is read without changing it. The value can be found in the input process image.
- **Bit 6=1:** The user data are written into a register. The process is complete once the status byte in the input process image has returned an acknowledgment (see example).



- **Bit 0 to 5: Address**

The address of the register to be addressed is entered in bits 0 to 5 of the control byte.

**Control byte in register mode (REG=1)**

MSB

REG=1	W/R	A5	A4	A3	A2	A1	A0
-------	-----	----	----	----	----	----	----

REG = 0<sub>bin</sub>: Process data exchange  
 REG = 1<sub>bin</sub>: Access to register structure

W/R = 0<sub>bin</sub>: Read register  
 W/R = 1<sub>bin</sub>: Write register

A5..A0 = register address  
 Addresses A5...A0 can be used to address a total of 64 registers.

**Example register communication**

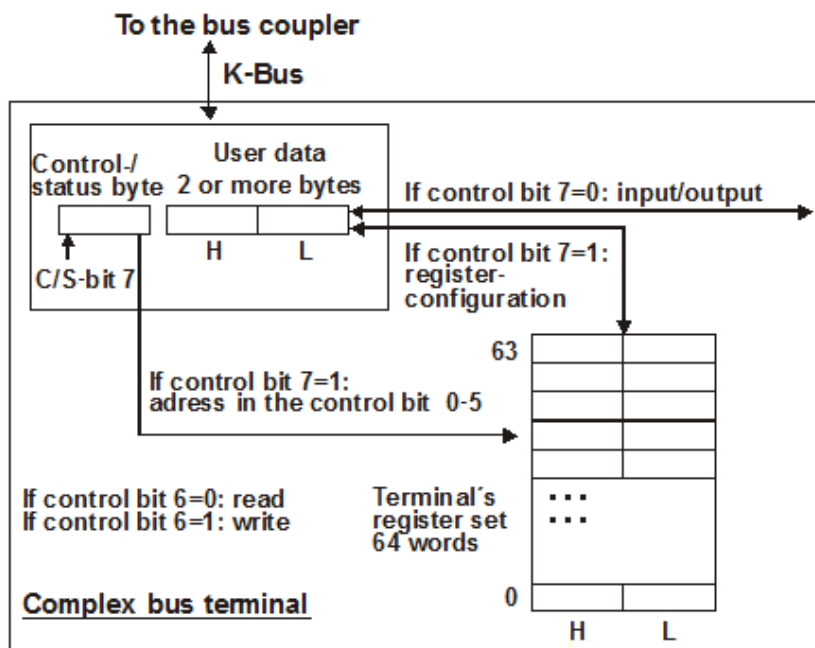

Fig. 16: Register mode control byte

The control or status byte occupies the lowest address of a logical channel. The corresponding register values are located in the following 2 data bytes. (The BK2000 is an exception: here, an unused data byte is inserted after the control or status byte, and the register value is therefore placed on a word boundary).

**Example 1**

Reading of register 8 in the BK2000 with a KL6021 and the end terminal:

If the following bytes are transferred from the controller to the terminal,

Byte	Byte0	Byte1	Byte2	Byte3
Name	Control	Not used	Data out, high byte	Data out, low byte
Value	0x88	0xXX	0xXX	0xXX

the terminal returns the following type identifier (0x1785 corresponds to unsigned integer 6021).

Byte	Byte0	Byte1	Byte2	Byte3
Name	State	Not used	Data in, high byte	Data in, low byte
Value	0x88	0x00	0x17	0x85

**Example 2**

Writing of register 31 in the BK2000 with an intelligent terminal and the end terminal:

If the following bytes (user codeword) are transferred from the controller to the terminal,

Byte	Byte0	Byte1	Byte2	Byte3
<b>Name</b>	Control	Not used	Data out, high byte	Data out, low byte
<b>Value</b>	0xDF	0XX	0x12	0x35

the user code word is set and the terminal returns the register address with the bit 7 for register access as acknowledgement.

Byte	Byte0	Byte1	Byte2	Data3
<b>Name</b>	State	Not used	Data in, high byte	Data in, low byte
<b>Value</b>	0x9F	0x00	0x00	0x00

## 5.6 Data exchange, function

### Control Byte for process data exchange

The control byte is transmitted from the terminal to the controller. It can be used in register mode (REG = 1) or in process data exchange (REG = 0) (see note in the annex). For setting up data exchange (handshake), the control and the status byte are used in process data exchange.

#### MSB

REG=0	OL2	OL1	OL0	0	IR	RA	TR
-------	-----	-----	-----	---	----	----	----

### Status byte in process data mode

The status byte is transmitted from the terminal to the controller. It contains the data required for handshake.

#### MSB

REG=0	IL2	IL1	IL0	BUF_F	IA	RR	TA
-------	-----	-----	-----	-------	----	----	----

### TR/TA: TRANSMIT-REQUEST/TRANSMIT-ACCEPTED bits

The handshake for data transmission is provided via this bit. A change of state in TR causes the data set defined via OL0-OL2 (5 bytes maximum) to be loaded into the transmission FIFO. The terminal signals execution of this instruction via TA.

**Example**

Output Control byte	Input Status byte	Comment
00000000	0XXXX0X0	Start data transmission
00100001 Data Bytes: In D0 and D1 Register data	0XXXX0X0	The controller instructs the terminal to send 2 data
...	...	...
00100001 Data Bytes: In D0 and D1	0XXXX0X1	The terminal has loaded 2 data into transmission FIFO; the command is executed
01010000 Data Bytes: In D0 to D4	0XXXX0X1 Data Bytes: DC	The controller instructs the terminal to send 5 data (D0-D4)
...	...	...
01010000 Data Bytes: In D0 and D1, register data	0XXXX0X0	The terminal has loaded 5 data into transmission FIFO; the command is executed

**RA/RR: RECEIVED-ACCEPTED/RECEIVED-REQUEST**

The terminal notifies the controller via a change of state in RR that the data quantity displayed in IL0-IL1 is located in D0-D4. The data shift is acknowledged in the control byte using RA; only then will new data be transmitted by the terminal to the controller.

**Example:**

Output Control byte	Input Status byte	Comment
00000000	0XXXX00X	Start data transmission
0XXX000X	0011X01X	The terminal instructs the controller to accept 3 data from D0-D2
...	...	...
0XXX001X	0011X01X	The controller has accepted data
0XXX001X	0101X00X	The terminal instructs the controller to accept 5 data from D0-D4
...	...	...
0XXX000X	0101X00X	The controller has accepted data

**IR/IA: INIT-REQUEST/INIT-ACCEPTED**

If IR is high, the terminal initializes. The send and receive functions are blocked, the FIFO pointers are reset and the interface is initialized with the values from the relevant registers (R32-R35, R18). The completion of the initialization is acknowledged by the terminal using IA.

**Example:**

Output Control byte	Input Status byte	Comment
0XXXXXXXX	0XXXXXXXX	Start data transmission
00000100	0XXXXXXXX	Initialization is requested by the controller
...	...	...
00000100	00000100	The terminal has completed the initialization
00000000	00000100	The controller requests data exchange
...	...	...
00000000	00000000	The terminal is ready

**BUF\_F: BUFFER-FULL\_Flag**

The receive FIFO is full. Data received now will be lost.

**Error handling**

If a parity, framing or overrun error occurs, the corresponding data is lost in transmission and will not be loaded into the receive FIFO of the terminal.

If the buffer is full, incoming data will be ignored.

In the event of an error, the corresponding diagnostic bits are set to R6

## 5.7 Examples of Register Communication

The numbering of the bytes in the examples corresponds to the display without word alignment.

### 5.7.1 Example 1: Reading the firmware version from register 9

**Output Data**

Byte 0: Control byte	Byte 1: DataOUT1, high byte	Byte 2: DataOUT1, low byte
0x89 (1000 1001 <sub>bin</sub> )	0xXX	0xXX

Explanation:

- Bit 0.7 set means: Register communication switched on.
- Bit 0.6 not set means: reading the register.
- Bits 0.5 to 0.0 specify the register number 9 with 00 1001<sub>bin</sub>.
- The output data word (byte 1 and byte 2) has no meaning during read access. To change a register, write the required value into the output word.

**Input Data (answer of the Bus Terminal)**

Byte 0: Status byte	Byte 1: DataIN1, high byte	Byte 2: DataIN1, low byte
0x89	0x33	0x41

Explanation:

- The terminal returns the value of the control byte as a receipt in the status byte.
- The terminal returns the firmware version 0x3341 in the input data word (byte 1 and byte 2). This is to be interpreted as an ASCII code:
  - ASCII code 0x33 represents the digit 3
  - ASCII code 0x41 represents the letter A
 The firmware version is thus 3A.

### 5.7.2 Example 2: Writing to a user register

#### ● Code word

In normal mode all user registers are read-only with the exception of Register 31. In order to deactivate this write protection you must write the code word (0x1235) into Register 31. If a value other than 0x1235 is written into Register 31, write protection is reactivated. Please note that changes to a register only become effective after restarting the terminal (power-off/power-on).

**I. Write the code word (0x1235) into register 31.**

**Output Data**

Byte 0: Control byte	Byte 1: DataOUT1, high byte	Byte 2: DataOUT1, low byte
0xDF (1101 1111 <sub>bin</sub> )	0x12	0x35

Explanation:

- Bit 0.7 set means: Register communication switched on.
- Bit 0.6 set means: writing to the register.
- Bits 0.5 to 0.0 specify the register number 31 with 01 1111<sub>bin</sub>.
- The output data word (byte 1 and byte 2) contains the code word (0x1235) for deactivating write protection.

**Input Data (answer of the Bus Terminal)**

Byte 0: Status byte	Byte 1: DataIN1, high byte	Byte 2: DataIN1, low byte
0x9F (1001 1111 <sub>bin</sub> )	0xFF	0xFF

Explanation:

- The terminal returns a value as a receipt in the status byte that differs only in bit 0.6 from the value of the control byte.
- The input data word (byte 1 and byte 2) is of no importance after the write access. Any values still displayed are invalid!

**II. Read Register 31 (check the set code word)**

**Output Data**

Byte 0: Control byte	Byte 1: DataOUT1, high byte	Byte 2: DataOUT1, low byte
0x9F (1001 1111 <sub>bin</sub> )	0xFF	0xFF

Explanation:

- Bit 0.7 set means: Register communication switched on.
- Bit 0.6 not set means: reading the register.
- Bits 0.5 to 0.0 specify the register number 31 with 01 1111<sub>bin</sub>.
- The output data word (byte 1 and byte 2) has no meaning during read access.

**Input Data (answer of the Bus Terminal)**

Byte 0: Status byte	Byte 1: DataIN1, high byte	Byte 2: DataIN1, low byte
0x9F (1001 1111 <sub>bin</sub> )	0x12	0x35

Explanation:

- The terminal returns the value of the control byte as a receipt in the status byte.
- The terminal returns the current value of the code word register in the input data word (byte 1 and byte 2).

**III. Write to Register 32 (change contents of the feature register)**

**Output data**

Byte 0: Control byte	Byte 1: DataIN1, high byte	Byte 2: DataIN1, low byte
0xE0 (1110 0000 <sub>bin</sub> )	0x00	0x02

Explanation:

- Bit 0.7 set means: Register communication switched on.
- Bit 0.6 set means: writing to the register.
- Bits 0.5 to 0.0 indicate register number 32 with  $10\ 0000_{\text{bin}}$ .
- The output data word (byte 1 and byte 2) contains the new value for the feature register.

### ⚠ CAUTION

#### Observe the register description!

The value of 0x0002 given here is just an example!

The bits of the feature register change the properties of the terminal and have a different meaning, depending on the type of terminal. Refer to the description of the feature register of your terminal (chapter *Register description*) regarding the meaning of the individual bits before changing the values.

#### Input data (response from the Bus Terminal)

Byte 0: Status byte	Byte 1: DataIN1, high byte	Byte 2: DataIN1, low byte
0xA0 ( $1010\ 0000_{\text{bin}}$ )	0xXX	0xXX

Explanation:

- The terminal returns a value as a receipt in the status byte that differs only in bit 0.6 from the value of the control byte.
- The input data word (byte 1 and byte 2) is of no importance after the write access. Any values still displayed are invalid!

#### IV. Read register 32 (check changed feature register)

##### Output Data

Byte 0: Control byte	Byte 1: DataOUT1, high byte	Byte 2: DataOUT1, low byte
0xA0 ( $1010\ 0000_{\text{bin}}$ )	0xXX	0xXX

Explanation:

- Bit 0.7 set means: Register communication switched on.
- Bit 0.6 not set means: reading the register.
- Bits 0.5 to 0.0 indicate register number 32 with  $10\ 0000_{\text{bin}}$ .
- The output data word (byte 1 and byte 2) has no meaning during read access.

#### Input Data (answer of the Bus Terminal)

Byte 0: Status byte	Byte 1: DataIN1, high byte	Byte 2: DataIN1, low byte
0xA0 ( $1010\ 0000_{\text{bin}}$ )	0x00	0x02

Explanation:

- The terminal returns the value of the control byte as a receipt in the status byte.
- The terminal returns the current value of the feature register in the input data word (byte 1 and byte 2).

#### V. Write register 31 (reset code word)

##### Output Data

Byte 0: Control byte	Byte 1: DataOUT1, high byte	Byte 2: DataOUT1, low byte
0xDF ( $1101\ 1111_{\text{bin}}$ )	0x00	0x00

Explanation:

- Bit 0.7 set means: Register communication switched on.
- Bit 0.6 set means: writing to the register.
- Bits 0.5 to 0.0 specify the register number 31 with  $01\ 1111_{bin}$ .
- The output data word (byte 1 and byte 2) contains 0x0000 for reactivating write protection.

**Input Data (answer of the Bus Terminal)**

Byte 0: Status byte	Byte 1: DataIN1, high byte	Byte 2: DataIN1, low byte
0x9F ( $1001\ 1111_{bin}$ )	0xXX	0xXX

Explanation:

- The terminal returns a value as a receipt in the status byte that differs only in bit 0.6 from the value of the control byte.
- The input data word (byte 1 and byte 2) is of no importance after the write access. Any values still displayed are invalid!

## 6 Appendix

### 6.1 Beckhoff Identification Code (BIC)

The Beckhoff Identification Code (BIC) is increasingly being applied to Beckhoff products to uniquely identify the product. The BIC is represented as a Data Matrix Code (DMC, code scheme ECC200), the content is based on the ANSI standard MH10.8.2-2016.

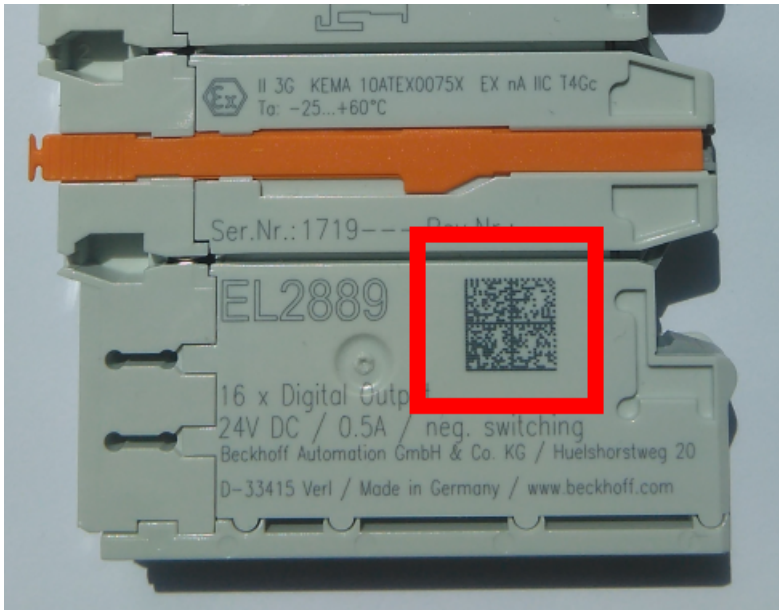

Fig. 17: BIC as data matrix code (DMC, code scheme ECC200)

The BIC will be introduced step by step across all product groups.

Depending on the product, it can be found in the following places:

- on the packaging unit
- directly on the product (if space suffices)
- on the packaging unit and the product

The BIC is machine-readable and contains information that can also be used by the customer for handling and product management.

Each piece of information can be uniquely identified using the so-called data identifier (ANSI MH10.8.2-2016). The data identifier is followed by a character string. Both together have a maximum length according to the table below. If the information is shorter, spaces are added to it.

Following information is possible, positions 1 to 4 are always present, the other according to need of production:



Position	Type of information	Explanation	Data identifier	Number of digits incl. data identifier	Example
1	Beckhoff order number	<b>Beckhoff order number</b>	1P	8	<b>1P</b> 072222
2	Beckhoff Traceability Number (BTN)	<b>Unique serial number, see note below</b>	SBTN	12	<b>SBTN</b> k4p562d7
3	Article description	<b>Beckhoff article description, e.g. EL1008</b>	1K	32	<b>1K</b> EL1809
4	Quantity	<b>Quantity in packaging unit, e.g. 1, 10, etc.</b>	Q	6	<b>Q</b> 1
5	Batch number	Optional: Year and week of production	2P	14	<b>2P</b> 401503180016
6	ID/serial number	Optional: Present-day serial number system, e.g. with safety products	51S	12	<b>51S</b> 678294
7	Variant number	Optional: Product variant number on the basis of standard products	30P	32	<b>30P</b> F971, 2*K183
...					

Further types of information and data identifiers are used by Beckhoff and serve internal processes.

**Structure of the BIC**

Example of composite information from positions 1 to 4 and with the above given example value on position 6. The data identifiers are highlighted in bold font:

**1P**072222**SBTN**k4p562d7**1K**EL1809 **Q**1 **51S**678294

Accordingly as DMC:



Fig. 18: Example DMC **1P**072222**SBTN**k4p562d7**1K**EL1809 **Q**1 **51S**678294

**BTN**

An important component of the BIC is the Beckhoff Traceability Number (BTN, position 2). The BTN is a unique serial number consisting of eight characters that will replace all other serial number systems at Beckhoff in the long term (e.g. batch designations on IO components, previous serial number range for safety products, etc.). The BTN will also be introduced step by step, so it may happen that the BTN is not yet coded in the BIC.

**NOTE**

This information has been carefully prepared. However, the procedure described is constantly being further developed. We reserve the right to revise and change procedures and documentation at any time and without prior notice. No claims for changes can be made from the information, illustrations and descriptions in this information.

## 6.2 Support and Service

Beckhoff and their partners around the world offer comprehensive support and service, making available fast and competent assistance with all questions related to Beckhoff products and system solutions.

### Beckhoff's branch offices and representatives

Please contact your Beckhoff branch office or representative for local support and service on Beckhoff products!

The addresses of Beckhoff's branch offices and representatives round the world can be found on her internet pages: <https://www.beckhoff.com>

You will also find further documentation for Beckhoff components there.

### Beckhoff Support

Support offers you comprehensive technical assistance, helping you not only with the application of individual Beckhoff products, but also with other, wide-ranging services:

- support
- design, programming and commissioning of complex automation systems
- and extensive training program for Beckhoff system components

Hotline: +49 5246 963 157  
Fax: +49 5246 963 9157  
e-mail: [support@beckhoff.com](mailto:support@beckhoff.com)

### Beckhoff Service

The Beckhoff Service Center supports you in all matters of after-sales service:

- on-site service
- repair service
- spare parts service
- hotline service

Hotline: +49 5246 963 460  
Fax: +49 5246 963 479  
e-mail: [service@beckhoff.com](mailto:service@beckhoff.com)

### Beckhoff Headquarters

Beckhoff Automation GmbH & Co. KG

Huelshorstweg 20  
33415 Verl  
Germany

Phone: +49 5246 963 0  
Fax: +49 5246 963 198  
e-mail: [info@beckhoff.com](mailto:info@beckhoff.com)  
web: <https://www.beckhoff.com>

## Table of figures

Fig. 1	KL6021 .....	8
Fig. 2	Connection for RS485 transfer .....	10
Fig. 3	Connection for RS422 transfer .....	10
Fig. 4	Spring contacts of the Beckhoff I/O components .....	11
Fig. 5	Attaching on mounting rail .....	12
Fig. 6	Disassembling of terminal .....	13
Fig. 7	Power contact on left side .....	14
Fig. 8	Standard wiring .....	16
Fig. 9	Pluggable wiring .....	16
Fig. 10	High Density Terminals .....	17
Fig. 11	Connecting a cable on a terminal point .....	18
Fig. 12	KS2000 configuration software .....	22
Fig. 13	Mapping for Lightbus Coupler, example: KL6021 .....	24
Fig. 14	Mapping for Profibus Coupler - example for KL6021 .....	25
Fig. 15	Mapping for Interbus Coupler - example for KL6021 .....	25
Fig. 16	Register mode control byte .....	33
Fig. 17	BIC as data matrix code (DMC, code scheme ECC200) .....	40
Fig. 18	Example DMC 1P072222SBTNk4p562d71KEL1809 Q1 51S678294 .....	41



More Information:  
[www.beckhoff.com/KL6021](http://www.beckhoff.com/KL6021)

Beckhoff Automation GmbH & Co. KG  
Hülshorstweg 20  
33415 Verl  
Germany  
Phone: +49 5246 9630  
[info@beckhoff.com](mailto:info@beckhoff.com)  
[www.beckhoff.com](http://www.beckhoff.com)

