

Documentation | EN

# SCT1xxx

Mini ring-type current transformer





# Table of contents

<b>1 Foreword</b> .....	<b>5</b>
1.1 Notes on the documentation .....	5
1.2 Safety instructions .....	6
<b>2 Product overview</b> .....	<b>8</b>
2.1 Introduction .....	8
2.2 Basics current transformers .....	9
2.3 Product categories – SCTxxx current transformer .....	14
2.4 Notes on class accuracy SCT transformers .....	23
<b>3 Technical data</b> .....	<b>24</b>
3.1 SCT1xxx   General .....	24
3.2 SCT1111   Mini ring-type current transformer for primary currents 0...32 A AC to 0...64 A AC, accuracy class 1, size 1 .....	26
<b>4 Commissioning</b> .....	<b>27</b>
<b>5 Application example</b> .....	<b>29</b>
5.1 Power measurement at a machine .....	29
<b>6 Appendix</b> .....	<b>31</b>
6.1 Documentation issue status .....	31
6.2 UL notes .....	32
6.3 Support and Service .....	33



# 1 Foreword

## 1.1 Notes on the documentation

### Copyright

© Beckhoff Automation GmbH & Co. KG, Germany.

The reproduction, distribution and utilization of this document as well as the communication of its contents to others without express authorization are prohibited.

Offenders will be held liable for the payment of damages. All rights reserved in the event of the grant of a patent, utility model or design.

### Disclaimer

The documentation has been prepared with care. The products described are, however, constantly under development.

We reserve the right to revise and change the documentation at any time and without prior announcement.

No claims for the modification of products that have already been supplied may be made on the basis of the data, diagrams and descriptions in this documentation.



EtherCAT® is registered trademark and patented technology, licensed by Beckhoff Automation GmbH, Germany.

### Trademarks

Beckhoff®, TwinCAT®, TwinCAT/BSD®, TC/BSD®, EtherCAT®, EtherCAT G®, EtherCAT G10®, EtherCAT P®, Safety over EtherCAT®, TwinSAFE®, XFC®, XTS® and XPlanar® are registered trademarks of and licensed by Beckhoff Automation GmbH. Other designations used in this publication may be trademarks whose use by third parties for their own purposes could violate the rights of the owners.

### Patent Pending

The EtherCAT Technology is covered, including but not limited to the following patent applications and patents: EP1590927, EP1789857, EP1456722, EP2137893, DE102015105702 with corresponding applications or registrations in various other countries.

### Intended audience

This description is only intended for the use of trained specialists in control and automation engineering who are familiar with the applicable national standards.

It is essential that the documentation and the following notes and explanations are followed when installing and commissioning these components.

It is the duty of the technical personnel to use the documentation published at the respective time of each installation and commissioning.

The responsible staff must ensure that the application or use of the products described satisfy all the requirements for safety, including all the relevant laws, regulations, guidelines and standards.

## 1.2 Safety instructions

### Description of instructions

In this documentation the following instructions are used.  
These instructions must be read carefully and followed without fail!

#### DANGER

##### **Serious risk of injury!**

Failure to follow this safety instruction directly endangers the life and health of persons.

#### WARNING

##### **Risk of injury!**

Failure to follow this safety instruction endangers the life and health of persons.

#### CAUTION

##### **Personal injuries!**

Failure to follow this safety instruction can lead to injuries to persons.

#### NOTICE

##### **Damage to environment/equipment or data loss**

Failure to follow this instruction can lead to environmental damage, equipment damage or data loss.



#### **Tip or pointer**

This symbol indicates information that contributes to better understanding.

### Exclusion of liability

All the components are supplied in particular hardware and software configurations appropriate for the application. Modifications to hardware or software configurations other than those described in the documentation are not permitted, and nullify the liability of Beckhoff Automation GmbH & Co. KG.

### Personnel qualification

This description is only intended for trained specialists in control, automation and drive engineering who are familiar with the applicable national standards.

### Intended use

If the equipment is used in a manner not specified by the manufacturer, the protection provided by the equipment may be impaired

### Safety regulations

Please note the following safety instructions and explanations!  
Product-specific safety instructions can be found on following pages or in the areas mounting, wiring, commissioning etc.

### Current transformer safety instructions

The following points must be noted:

- The applicable laws, standards and regulations.
- The state of the art at the time of installation.
- The technical rules.
- The operating instructions.

- The fact that operating instructions can only list general regulations and that these regulations must be followed.
- Check the device carefully for transport damage prior to commissioning. The device must not be put into operation if it is mechanically damaged.
- The devices described are intended for installation by qualified electricians and may only be installed in electrical plant rooms or in closed housings. Any other use or the disregard of these application notes will result in the loss of the warranty/guarantee.
- The devices may only be installed in dry indoor rooms.
- Do not mount on highly flammable materials.
- Operation with a higher current than the rated current specified on the name plate can lead to overheating of the current transformer and thus to burns.

## 2 Product overview

### 2.1 Introduction

#### SCTxxxx | Current transformers for power measurement



Fig. 1: SCT current transformers

The SCT current transformers allow reliable power sensor technology to be implemented directly in the field as an integral part of the PC-based control system. Users can choose between two concepts, which are highly scalable thanks to various designs and performance classes and are thus suitable for any application. The SCT series portfolio is extremely diversified, ranging from the low-cost 3-phase transformer sets for properties and standard industrial transformers for mechanical engineering, through to solutions for test benches with particularly high requirements for accuracy.

The choice of the right product category [► 14] depends on the type of usage:

Whilst the data acquisition can be implemented cost-efficiently and with high measurement accuracy using the ring-type current transformers, particularly in new systems, the split-core current transformers are suitable as an uncomplicated retrofit solution due to the simplicity of their attachment.

The SCT5xxx transformers occupy a special position. These are not intended for energy measurement, but are specially designed for highly accurate detection of differential currents. In addition, unlike the other SCT transformers, they are also suitable for DC currents and thus meet the differential current detection according to the Type B definition. Therefore, AC as well as DC currents up to 100 kHz can be measured by a fluxgate measuring principle.



## 2.2 Basics current transformers

Basic information on the technology area of current transformers is given in the following. The information is of general nature; so it is imperative to check the extent to which these notes apply to your specific application.

### Function and design

A current transformer is a transforming device that transforms an input current into a processable current signal at the output. A current transformer is mainly used to transform currents of large magnitudes to directly measurable, smaller values in the milliampere or small ampere range. With a classic current transformer, the input current is proportional to the output current. Due to the physical principle and the mechanical construction, the current signal is transmitted galvanically isolated to the evaluation electronics.

A current transformer basically consists of a small number of windings on the primary side and a larger number of windings on the secondary side. The current to be converted flows through the primary side. The windings are usually wound on an alternating magnetic ferrite ring core.

A typical transformer type is the ring core or ring-type current transformer. The current rail or current-carrying cable is often used as the primary winding, which is guided through the toroidal core of the transformer. Thus, the rail or line forms the primary winding with one turn. The secondary winding is located on the ring core. The transformation is determined by the ratio of the number of primary and secondary windings. The classic structure of a ring-type current transformer is shown in the following figure.

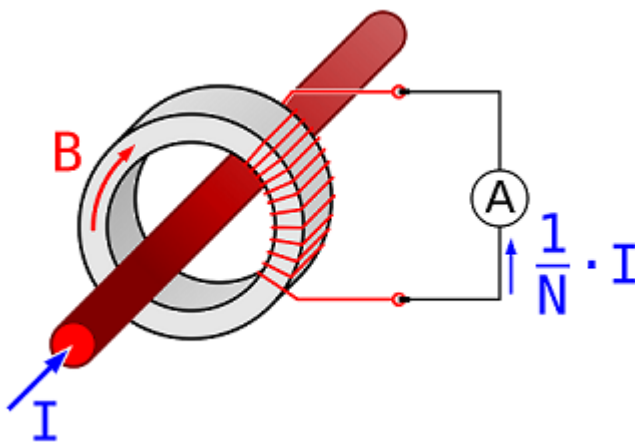

Fig. 2: Principle ring-type current transformer

Another classic type is the coiled current transformer. In this type of transformer, the primary winding is a current-carrying wire which is wound around the ring core on the primary side. In this case, the primary winding number is  $> 1$ , but smaller than the secondary winding number. The principle is shown in the following figure

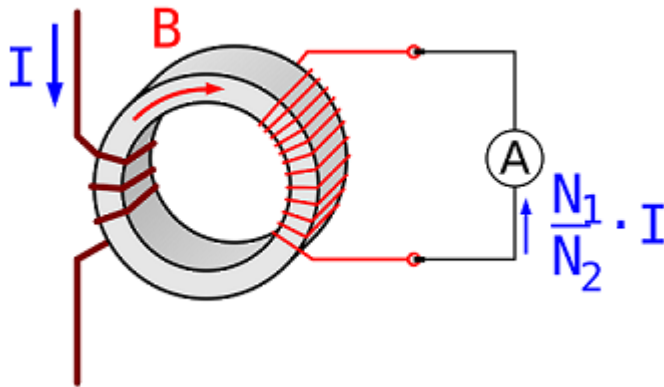

Fig. 3: Principle coil current transformer

### ⚠ WARNING

#### Dangerous voltages with secondary side not connected

The secondary winding must be connected to a current measuring device or short-circuited, otherwise high core losses or dangerous voltages may occur on the secondary side. Before replacing the measuring electronics in the secondary circuit, the current transformer must therefore be short-circuited at its secondary terminals.



#### Grounding of secondary terminals

According to DIN VDE 0141 (01/2000) paragraph 5.3.4, current and voltage transformers for nominal voltages from  $U_m = 3.6 \text{ kV}$  must be grounded on the secondary side. For low voltages ( $U_m \leq 1.2 \text{ kV}$ ), grounding is not required if the transformer housings do not have any metal surfaces with large contact areas.

#### Characteristic values and calculation

In principle, the construction, and thus also the calculation, correspond to a normal transformer. The basic relationship between input and output current is determined by the ratio of the number of turns  $N$  of the primary and secondary sides. An important characteristic value in the design of a current transformer is therefore the transformer ratio.

$$I_{\text{Out}} = N_1/N_2 \cdot I_{\text{In}}$$

**Technical terms of current transformers**

<b>Term</b>	<b>Explanation</b>
<b>Primary rated current <math>I_{pr}</math></b> (alternative symbol $I_N$ )	Value of the rated current on the primary side
<b>Secondary rated current <math>I_{sr}</math></b>	Value of the rated current on the secondary side.
<b>Rated power <math>S_r</math></b>	Value of apparent power (in [VA]) that the transformer can deliver to the secondary circuit at secondary rated current and rated load
<b>Rated frequency <math>f_R</math></b>	Value of the rated frequency.
<b>Accuracy class</b>	Indication that the measurement deviations are within specified limits under prescribed conditions of use.
<b>Rated insulation level <math>U_m</math></b>	<p>Highest voltage; RMS value of the highest conductor-to-conductor voltage for which a measuring transformer is rated with respect to its insulation</p> <p>The value of the rated insulation level is given in three values:</p> <ol style="list-style-type: none"> <li>1. maximum value of the conductor-to-conductor voltage for which the insulation of the transformers is designed;</li> <li>2. value of the rated short-duration power frequency withstand voltage (50 Hz, 1 min), with which the insulation safety of the devices is tested</li> <li>3. value of the surge voltage level (this specification is mostly unoccupied here, since according to IEC 61869/1 a specification is only required for transformers with a conductor-to-conductor voltage of &gt; 1.2 kV)</li> </ol>
<b>Overcurrent limiting factor (FS)</b>	Ratio of rated limiting current to primary rated current.
<b>Rated continuous thermal current <math>I_{cth}</math></b>	Value of the continuous current in the primary winding at which the overtemperature does not exceed the value specified in the standard, with the secondary winding loaded with the rated load.
<b>Rated short-time thermal current <math>I_{th}</math></b>	Value of short-time current for a limited time in the primary winding at which the overtemperature does not exceed the value specified in the standard, with the secondary winding loaded with the rated load.
<b>Rated peak current <math>I_{dyn}</math></b>	Maximum value of the primary current whose electromagnetic force effect does not cause electrical and mechanical damage to the current transformer with short-circuited secondary winding.
<b>"Open voltage" of current transformers</b>	<p>Current transformers which are not directly connected to a load must be short-circuited on the secondary side for safety reasons!</p> <p>A current transformer operated open on the secondary side induces very high peak voltage values at its secondary terminals. The magnitudes of these voltages can reach values of up to several kilovolts, depending on the dimensioning of the current transformer, and thus represent a danger to persons and the functional safety of the transformer. For safety reasons, open operation should generally be avoided in order to prevent magnetization of the core iron during secondary open operation.</p>
<b>Grounding of secondary terminals</b>	According to DIN VDE 0141 (01/2000) paragraph 5.3.4, current and voltage transformers for nominal voltages from $U_m = 3.6$ kV must be grounded on the secondary side. For low voltages ( $U_m \leq 1.2$ kV), grounding is not required if the transformer housings do not have any metal surfaces with large contact areas.

### Principle of the fluxgate current measurement technology

While all SCT transformers except the SCT5xxx are based on the transformer principle described above, the technology of the all-current sensitive differential current transformers is fundamentally different.

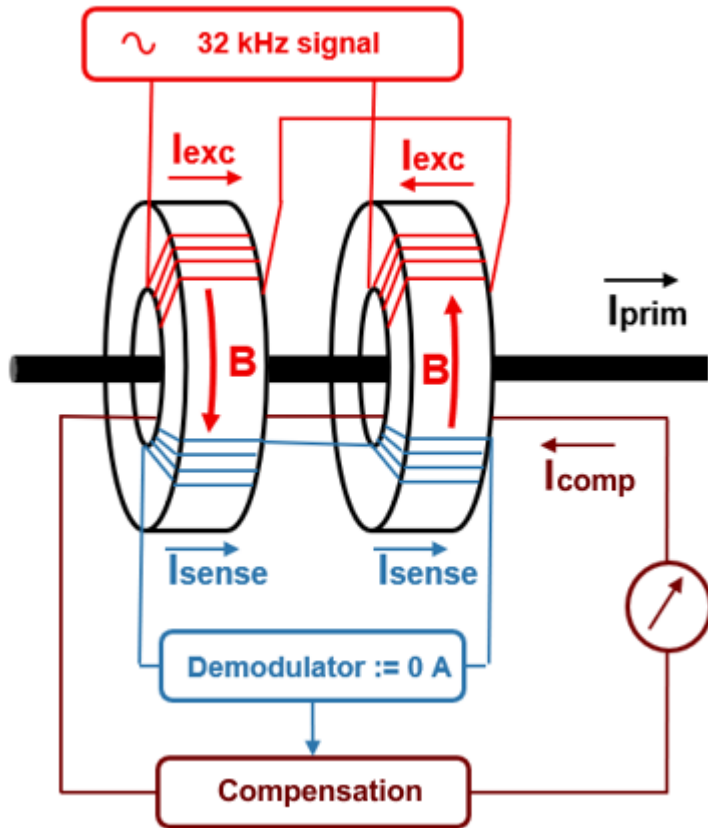

Fig. 4: Principle fluxgate current measurement technology

The measuring principle of the SCT5xxx is based on a differential current measurement of two oppositely excited cores in the transducer. For this purpose, both cores are brought into saturation with an excitation winding (red) with an internally generated 32 kHz signal, whereby the first core is driven in the positive and the second in the negative range of the y-axis. See fig.)

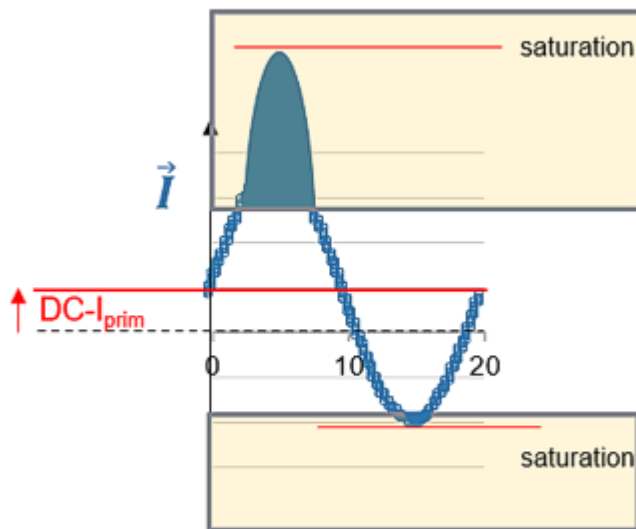

Fig. 5: Characteristics fluxgate current measurement technology

The detection winding now measures the induced current of the excitation winding (blue). If the measuring current  $I_{\text{prim}}$  is 0, then 0 A is also measured, since no compensating current is generated for compensation.

If the measuring current  $I_{\text{prim}}$  is not equal to 0, a compensating current is generated through both cores, which again compensates for the disproportion of the magnetic flux density  $B$  in core 1 and core 2. Due to the compensation,  $I_{\text{sense}}$  is 0 again.

The measured compensating current provides information about the current to be measured  $I_{\text{prim}}$ .

Together with a fixed excitation frequency, this leads to improved accuracy and stability.

### General description of the fluxgate current measurement technology

The SCT series SCT5xxx is used for monitoring differential currents in electrical power supply systems that do not require fast system shutdown. The SCT5xxx type B/B+ can measure DC and AC residual currents at frequencies up to 100 kHz.

This makes this differential current transformer compatible with a wide range of industrial applications, loads and power sources. With its user-selectable settings, this series provides a flexible platform for differential current measurement suitable for any possible application, both at the time of industrial plant design and when expanding with new modern loads operating at DC voltages or high switching frequencies that increase the amount of leakage current in the system.

The SCT5xxx have an analog 4 - 20 mA output, which represents the real-time RMS value (TRMS) of the measured residual current for connection to a PLC, for example. In addition, a potential-free relay output (NO / NC) with a freely selectable residual current limit can be used for warning or even system shutdown if the TRMS residual current measured value has exceeded the preset value. The status of the relay output is replicated on an LED for visual indication on the device itself. A built-in test button and an external test button input are provided for periodic testing of the SCT5xxx according to the applicable product standards. Only a single 24 Vdc power supply should be provided for the SCT5xxx.

## 2.3 Product categories – SCTxxxx current transformer

Breakdown of the type designation of the SCT current transformer

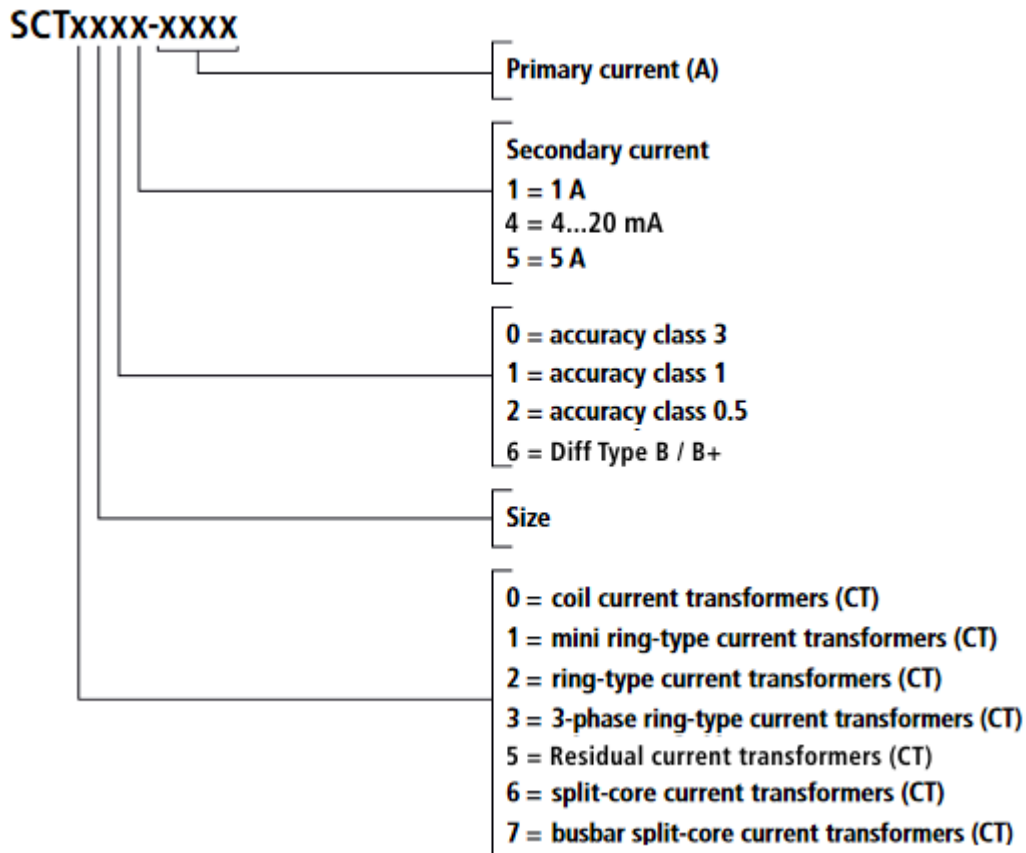

Fig. 6: Designation key of the SCT current transformers

**Coil current transformers**



Fig. 7: SCT0xxx

In order to guarantee the power transmission, current transformers need a correspondingly large measuring core volume with decreasing primary nominal currents. The dimensions of standard current transformers would quickly hit their limits on the basis of this physical principle. The SCT0xxx coil current transformers with electrical isolation are specially designed for these low primary nominal currents and are used in corresponding applications.

Coil current transformers	
<u>SCT0111</u>	Accuracy class 1, Primary current 0...1 A AC to 0...30 A AC, Secondary current 1 A AC
<u>SCT0121</u>	Accuracy class 0.5, Primary current 0...1 A AC to 0...30 A AC, Secondary current 1 A AC

**Mini ring-type current transformer**

Fig. 8: SCT1xxx

The SCT1111 mini ring-type current transformer can be positioned on a DIN rail by means of snap-on mounting and is thus suitable for measurements in very tight installation spaces, e.g. directly in the sub-distribution unit. Two current transformers are attached to the DIN rail, while the third current transformer is plugged into the fastened current transformers. The connection is realized via removable picoMAX® connectors, which enables pre-wiring.

Mini ring-type current transformer	
SCT1111	Accuracy class 1, Primary current 0...32 A AC to 0...64 A AC, Secondary current 1 A AC, Max. diameter round conductor 7.6 mm (size 1)



**Ring-type current transformer**

Fig. 9: SCT2xxx

The SCT2xxx series offers a large selection of ring-type current transformers for primary currents from 60 to 2500 A in six sizes and two accuracy classes. The innovative screwless connection technology for rigid and flexible conductors saves time – ferrules can be dispensed with here.

Ring-type current transformer	
<u>SCT2111</u>	Accuracy class 1, Primary current 0...60 A AC to 0...500 A AC, Secondary current 1 A AC, Max. diameter round conductor 25.7 mm (size 1)
<u>SCT2121</u>	Accuracy class 0.5, Primary current 0...125 A AC to 0...600 A AC, Secondary current 1 A AC, Max. diameter round conductor 25.7 mm (size 1)
<u>SCT2211</u>	Accuracy class 1, Primary current 0...600 A AC / 750 A AC, Secondary current 1 A AC, Max. diameter round conductor 31.8 mm (size 2)
<u>SCT2221</u>	Accuracy class 0.5, Primary current 0...600 A AC / 750 A AC, Secondary current 1 A AC, Max. diameter round conductor 31.8 mm (size 2)
<u>SCT2311</u>	Accuracy class 1, Primary current 0...800 A AC / 1000 A AC, Secondary current 1 A AC, Max. diameter round conductor 43.7 mm (size 3)
<u>SCT2321</u>	Accuracy class 0.5, Primary current 0...800 A AC / 1000 A AC, Secondary current 1 A AC, Max. diameter round conductor 43.7 mm (size 3)
<u>SCT2411</u>	Accuracy class 1, Primary current 0...1250 A AC / 1500 A AC, Secondary current 1 A AC, Max. diameter round conductor 43.7 mm (size 4)
<u>SCT2421</u>	Accuracy class 0.5, Primary current 0...1250 A AC / 1500 A AC, Secondary current 1 A AC, Max. diameter round conductor 43.7 mm (size 4)
<u>SCT2515</u>	Accuracy class 1, Primary current 0...2000 A AC, Secondary current 5 A AC, Max. diameter round conductor 54.7 mm (size 5)
<u>SCT2525</u>	Accuracy class 0.5, Primary current 0...2000 A AC, Secondary current 5 A AC, Max. diameter round conductor 54.7 mm (size 5)
<u>SCT2615</u>	Accuracy class 1, Primary current 0...2500 A AC, Secondary current 5 A AC, Max. diameter round conductor 70 mm (size 6)
<u>SCT2625</u>	Accuracy class 0.5, Primary current 0...2500 A AC, Secondary current 5 A AC, Max. diameter round conductor 70 mm (size 6)

**3-phase ring-type current transformers**



Fig. 10: SCT3xxx

The compact SCT3xxx 3-phase ring-type current transformers for direct mounting below commonly used power switches measure primary currents from 3 x 50 to 3 x 600 A, with secondary currents of 1 or 5 A. The SCT3xxx series is available throughout in accuracy class 1 and is supplemented by the SCT3121-0125 and SCT3121-0150 current transformers in accuracy class 0.5.

3-phase ring-type current transformers	
<u>SCT3111</u>	Accuracy class 1, Primary current 3 x 0...50 A AC to 3 x 0...150 A AC, Secondary current 1 A AC, Max. diameter round conductor 13.5 mm (size 1)
<u>SCT3121</u>	Accuracy class 0.5, Primary current 3 x 0...125 A AC / 3 x 0...150 A AC, Secondary current 1 A, Max. diameter round conductor 13.5 mm (size 1)
<u>SCT3215</u>	Accuracy class 1, Primary current 3 x 0...100 A AC to 3 x 0...250 A AC, Secondary current 5 A AC, Max. diameter round conductor 18 mm (size 2)
<u>SCT3315</u>	Accuracy class 1, Primary current 3 x 0...250 A AC to 3 x 0...600 A AC, Secondary current 5 A AC, Max. diameter round conductor 22 mm (size 3)

### Ring-type current transformer for differential current measurement

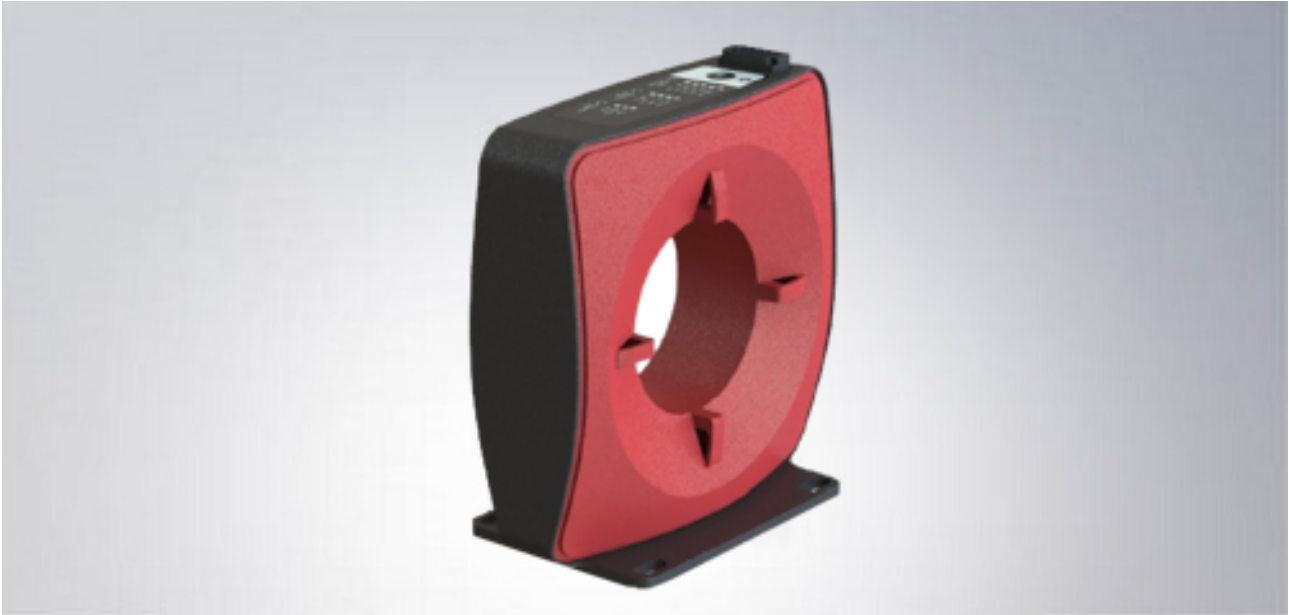

Fig. 11: SCT5xxx

The increasing prevalence of DC loads (e.g., LED lighting, DC motor drives, 48 V DC bus systems, etc.), distributed DC generation (e.g., PV systems, UPS, batteries, etc.), and high-frequency converters (e.g., SMPS, motor drives, etc.) in industrial environments makes it increasingly difficult to reliably measure insulation faults with conventional current transformers designed for AC 50/60 Hz with limited measurement bandwidth.

Differential current transformers of the SCT5xxx series can be used here. Monitoring residual currents with the SCT5xxx in real-time in a power system opens up the possibility of evaluating the condition of the electrical insulation based on the actual measured value, so that the long-term trend of the residual current value can be used for planning maintenance to detect significant deterioration of the insulation.

This means that residual current monitors (SCT5xxx) used in a condition-based monitoring scheme Industrie 4.0-Standards, can detect faults in a timely manner and increase the availability of power supplies or plants at a much lower cost than conventional, expensive, and time-consuming high-voltage insulation testing.

Ring-type current transformer for differential current measurement	
<u>SCT5564</u>	Measuring ranges 400 mA / 2 A, type B / B+, transformer opening 70 mm

**Split-core current transformers**



Fig. 12: SCT6xxx

The separable measuring system of the SCT6xxx split-core current transformers enables flexible retrofitting without disconnecting the primary conductor. Due to the minimal installation effort, they are suitable for use in places that are difficult to access or where space is limited. Four sizes are available. Accuracy class 3 is suitable for primary currents from 60 to 150 A, accuracy class 1 for 200 to 1000 A.

Split-core current transformers	
<u>SCT6101</u>	Accuracy class 3, Primary current 0...60 A AC to 0...150 A AC, Secondary current 1 A AC, Max. diameter round conductor 18.5 mm (size 1)
<u>SCT6311</u>	Accuracy class 1, Primary current 0...200 A AC / 0...250 A AC, Secondary current 1 A AC, Max. diameter round conductor 18.5 mm (size 3)
<u>SCT6321</u>	Accuracy class 0.5, Primary current 0...200 A AC / 0...250 A AC, Secondary current 1 A AC, Max. diameter round conductor 18.5 mm (size 3)
<u>SCT6411</u>	Accuracy class 1, Primary current 0...300 A AC to 0...500 A AC, Secondary current 1 A AC, Max. diameter round conductor 27.9 mm (size 4)
<u>SCT6421</u>	Accuracy class 0.5, Primary current 0...400 A AC / 0...500 A AC, Secondary current 1 A AC, Max. diameter round conductor 27.9 mm (size 4)
<u>SCT6615</u>	Accuracy class 1, Primary current 0...600 A AC / 0...750 A AC, Secondary current 5 A AC, Max. diameter round conductor 42.4 mm (size 6)
<u>SCT6625</u>	Accuracy class 0.5, Primary current 0...600 A AC / 0...750 A AC, Secondary current 5 A AC, Max. diameter round conductor 42.4 mm (size 6)
<u>SCT6715</u>	Accuracy class 1, Primary current 0...800 A AC / 0...1000 A AC, Secondary current 5 A AC, Max. diameter round conductor 2 x 42.4 mm (size 7)
<u>SCT6725</u>	Accuracy class 0.5, Primary current 0...800 A AC / 0...1000 A AC, Secondary current 5 A AC, Max. diameter round conductor 2 x 42.4 mm (size 7)

## Busbar split-core current transformers



Fig. 13: SCT71xx

Like the SCT6xxx series, the SCT7xxx busbar split-core current transformers for primary currents up to 5000 A can be retrofitted to existing systems with no great mounting effort. From 500 A, there is a choice between accuracy class 0.5 and 1 for each primary current. The SCT7105-0100 and SCT7105-200 current transformers support accuracy class 3.

Busbar split-core current transformers	
<a href="#">SCT7105</a>	Accuracy class 3, Primary current 0...100 A AC / 0...200 A AC, Secondary current 5 A AC, Max. diameter round conductor 20 mm (size 1)
<a href="#">SCT7115</a>	Accuracy class 1, Primary current 0...200 A AC / 0...450 A AC, Secondary current 5 A AC, Max. diameter round conductor 20 mm (size 1)
<a href="#">SCT7125</a>	Accuracy class 0.5, Primary current 0...400 A AC, Secondary current 5 A AC, Max. diameter round conductor 20 mm (size 1)
<a href="#">SCT7215</a>	Accuracy class 1, Primary current 0...500 A AC / 0...600 A AC, Secondary current 5 A AC, Max. diameter round conductor 50 mm (size 2)
<a href="#">SCT7225</a>	Accuracy class 0.5, Primary current 0...500 A AC / 0...600 A AC, Secondary current 5 A AC, Max. diameter round conductor 50 mm (size 2)
<a href="#">SCT7315</a>	Accuracy class 1, Primary current 0...750 A AC to 0...1500 A AC, Secondary current 5 A AC, Max. diameter round conductor 80 mm (size 3)
<a href="#">SCT7325</a>	Accuracy class 0.5, Primary current 0...750 A AC to 0...1500 A AC, Secondary current 5 A AC, Max. diameter round conductor 80 mm (size 3)
<a href="#">SCT7415</a>	Accuracy class 1, Primary current 0...1500 A AC to 0...5000 A AC, Secondary current 5 A AC, Max. diameter round conductor 80 mm (size 4)
<a href="#">SCT7425</a>	Accuracy class 0.5, Primary current 0...1500 A AC to 0...5000 A AC, Secondary current 5 A AC, Max. diameter round conductor 80 mm (size 4)

## 2.4 Notes on class accuracy SCT transformers

Current transformers are divided into classes according to their accuracy. The Beckhoff SCT current transformers are available in the standard accuracy classes 0.5; 1 and 3, depending on the product category. The class designation corresponds to an error curve with regard to current amplitude and angular error. Beckhoff SCT current transformers conform to the IEC 61869 standard.

The accuracy classes of current transformers are related to the rated current. If current transformers are operated with a current that is low in relation to the rated current, the measuring accuracy decreases. The following tables show the fault limit values taking into account the rated current values:

Class accuracy	Current error (±) in % at % of rated current				
	5 %	20 %	50 %	100 %	120 %
<b>0,5</b>	1,5 %	0,75 %	-	0,5 %	0,5 %
<b>1</b>	3,0 %	1,5 %	-	1,0 %	1,0 %
<b>3</b>	-	-	3 %	-	3 %

Class accuracy	Phase shift/error angle (±) at % of rated current									
	Angular minutes [ ' ]					Radians [ rad ]				
	5 %	20 %	50 %	100 %	120 %	5 %	20 %	50 %	100 %	120 %
<b>0,5</b>	90'	45'	-	30'	30'	2,7 rad	1,35 rad	-	0,9 rad	0,9 rad
<b>1</b>	180'	90'	-	60'	60'	5,4 rad	2,7 rad	-	1,8 rad	1,8 rad
<b>3</b>	-	-	-	-	-	-	-	-	-	-

Accuracy classes vs. measurement error

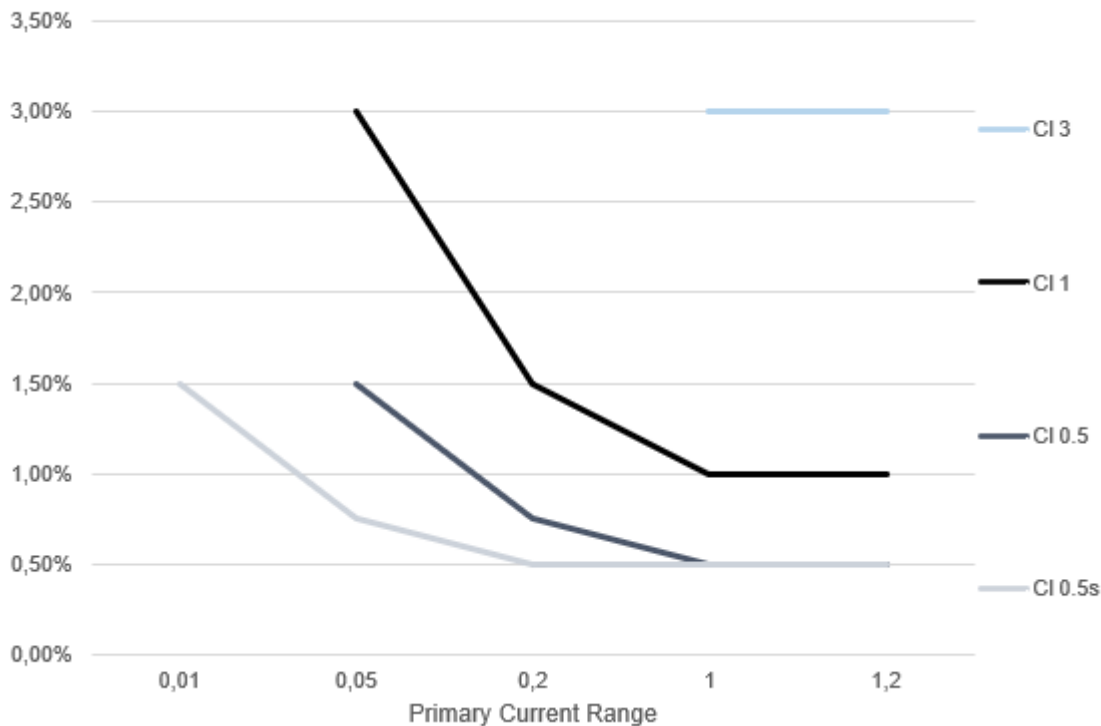

Fig. 14: Characteristic curves accuracy classes/primary current

### ● Adjusting the transducer rating

**i** In order to use the optimum accuracy of the transducer, you must ensure a suitable transducer rating in your application through the wiring between the transducer and the measuring terminal. This is done by using 0.25 to 1.0 times the rated power of the transducer.

Additional resistors in the secondary path can be used to match the transducer and measuring terminal to each other.

### 3 Technical data

#### 3.1 SCT1xxx | General

Primary side	SCT11xx-xxxx
Thermal rated continuous current $I_{cth}$	$1,0 * I_N$
Rated short-time thermal current $I_{th}$	$60 * I_N/1 s$
Rated impulse current $I_{dyn}$	$2,5 * I_{th}$
Rated frequency $f_R$	50..60 Hz
Secondary side	SCT11xx-xxxx
Secondary rated current $I_{sr}$	1 A
Overcurrent limiting factor	FS5
Operating conditions	SCT11xx-xxxx
Permissible ambient temperature range during operation	-5...+50 °C
Permissible ambient temperature range during storage	-25 ... +70 °C
Permissible relative humidity	5 ... 85 %
Operating height	Up to 2000 m
Protection class	IP20
Insulation characteristics	SCT11xx-xxxx
Rated insulation level $U_m$	0,72/3/- kV
Insulation class	E
General data	SCT11xx-xxxx
Max. Diameter conductor bushing primary conductor	7,5 mm
Connection technology secondary	picoMAX® 3,5
Conductor cross section secondary	0,2 ... 1,5 mm <sup>2</sup> / 24-14 AWG
Stripping length	8 - 9 mm / 0,31 - 0,35 in
Size	1
Dimensions (W x H x D)	27,5 mm x 46,5 mm x 19 mm
Weight	50 g
Standards and regulations	SCT11xx-xxxx
Approvals/Markings <sup>*)</sup>	CE
Standards/Regulations	IEC 61869-1; IEC 61869-2; IEC 61010-1

\*) Real applicable approvals/markings see type plate on the side (product marking).

#### SCT1xxx dimensions, size 1

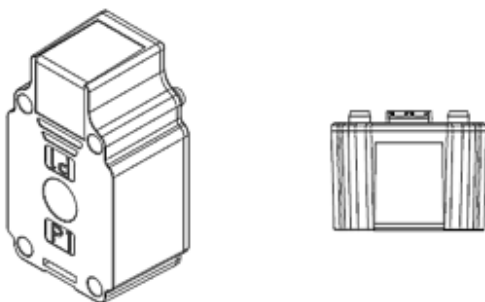

Fig. 15: Isometric view, top view



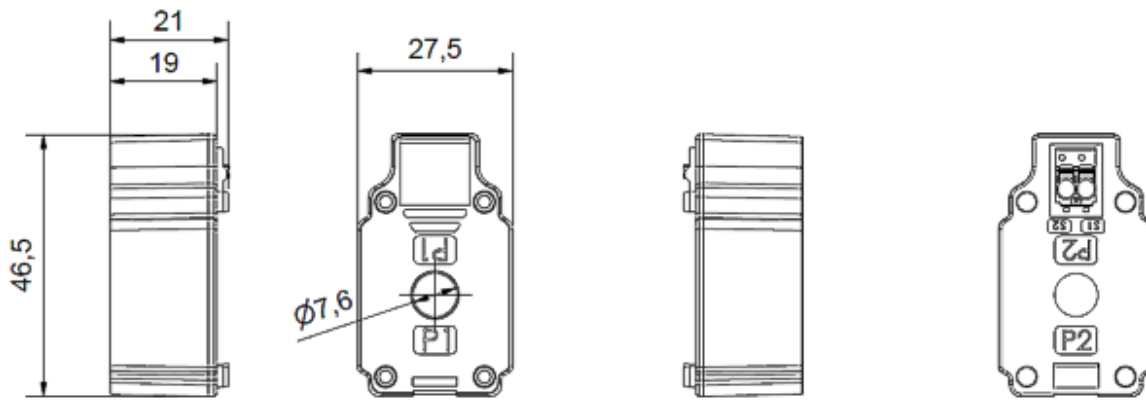

Fig. 16: Right side view, front view, left side view; all dimensions in mm

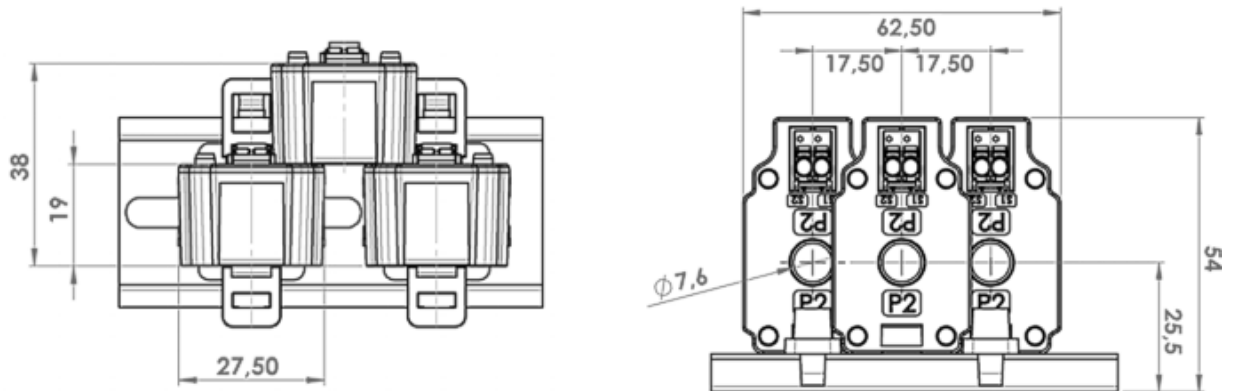

Fig. 17: Top view, front view; mounting with snap-on mounting [ZB8201-0110](#) [► 28] (accessory), all dimensions in mm

### 3.2 SCT1111 | Mini ring-type current transformer for primary currents 0...32 A AC to 0...64 A AC, accuracy class 1, size 1

Technical data	SCT1111-xxxx
Accuracy class	1
Primary current $I_N$	0...32 A AC to 0...64 A AC
Secondary current $I_{sr}$	1 A AC

Versions	
SCT1111-0032	ratio 32/1, rated power 0.2 VA
SCT1111-0035	ratio 35/1, rated power 0.2 VA
SCT1111-0040	ratio 40/1, rated power 0.3 VA
SCT1111-0050	ratio 50/1, rated power 0.4 VA
SCT1111-0060	ratio 60/1, rated power 0.4 VA
SCT1111-0064	ratio 64/1, rated power 0.5 VA

## 4 Commissioning

**⚠ DANGER**

**Open transformer circuits lead to electric shock and arc flashover!**

Disregarding this will result in death, physical injury or considerable damage to property!

- Never open the secondary circuit of the current transformer under load.
- Short-circuit the secondary current terminals of the current transformer before removing the device.

**⚠ WARNING**

**Hazardous voltage can lead to electric shock and burns!**

- Make sure that the details on the name plate and in the "Technical data" correspond to the operating parameters of the system.
- Switch the system off before commencing with the installation!

**⚠ WARNING**

**Induction of high voltages into the secondary circuit!**

- If the secondary circuit of the current transformer is not under load (open), high voltages are induced on its secondary terminals. The voltage values occurring there represent a danger to persons and the functional safety of the current transformer.
- "Open operation", i.e. operation of the current transformer without secondary wiring, must be avoided at all costs.
- Interrupt the power supply of the primary conductor and secure against being switched on again inadvertently.
- Install the current transformer on the primary conductor.
- To do this, feed the primary conductor (round conductor) through the window aperture of the current transformer housing. The window aperture is marked with "P1" and "P2".
- Make the secondary connections.
- Observe the markings "S1" and "S2" of the secondary terminals

**NOTICE**

**Observe the conductor cross-sections and lengths!**

The conductor cross-sections and lengths specified below must be adhered to for trouble-free function!

Conductor cross-section mm <sup>2</sup>	Power loss VA/m
0.5	0.070
0.75	0.047
1.0	0.035
1.5	0.023

## Measuring circuit

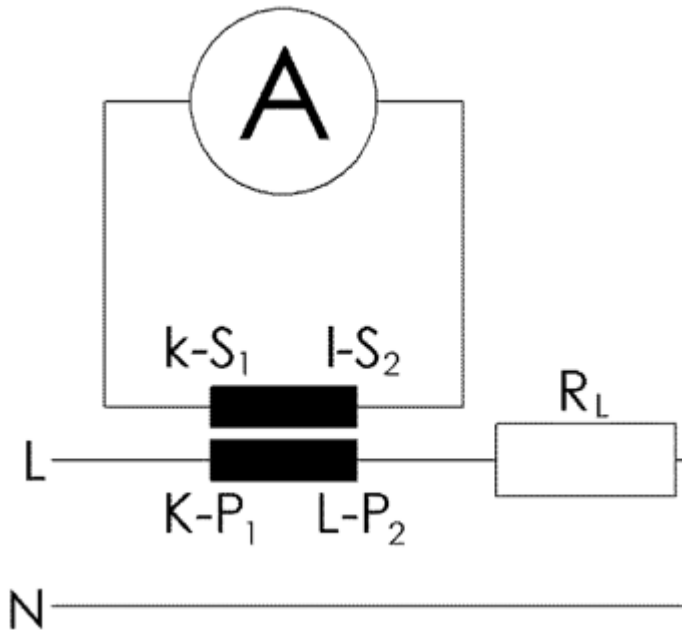

Fig. 18: Measuring circuit - **SCT0xxx/SCT1xxx/SCT2xxx** transformer

## Assembly notes

- To fasten the device to a mounting plate, use the optionally available snap-on mounting ([ZB8201-0110](#) [[▶ 28](#)]) for DIN rails.
- This can be fastened to the mounting plate with two screws, max. Ø 5 mm.
- Fastening to a 35 mm DIN rail also takes place with the help of the optionally available snap-on mounting [ZB8201-0110](#) [[▶ 28](#)]
- Check whether the current transformer is mounted correctly and the secondary conductors are connected correctly.
- Switch on the power supply to the primary conductor again.



Fig. 19: Snap-on mounting, **ZB8201-0110**

## 5 Application example

### 5.1 Power measurement at a machine

**⚠ WARNING**

**WARNING: Risk of electric shock!**

Bring the Bus Terminal system into a safe, voltage-free state before starting mounting, disassembly or wiring of the Bus Terminals!

**NOTICE**

**Attention! Risk of device damage!**

Avoid confusing the current and voltage circuit during connection, since the direct connection of mains voltage to the terminal points for the current transformers (typical input resistance 100 mΩ) would destroy the power measurement terminal!

**EL3443**

- The voltage is measured via connections L1, L2, L3 and N.
- The current is measured via three current transformers (e.g. from the Beckhoff SCT series) and the connections  $I_{L1}$ ,  $I_{L2}$ ,  $I_{L3}$  and  $I_N$  (star point of the current transformers).

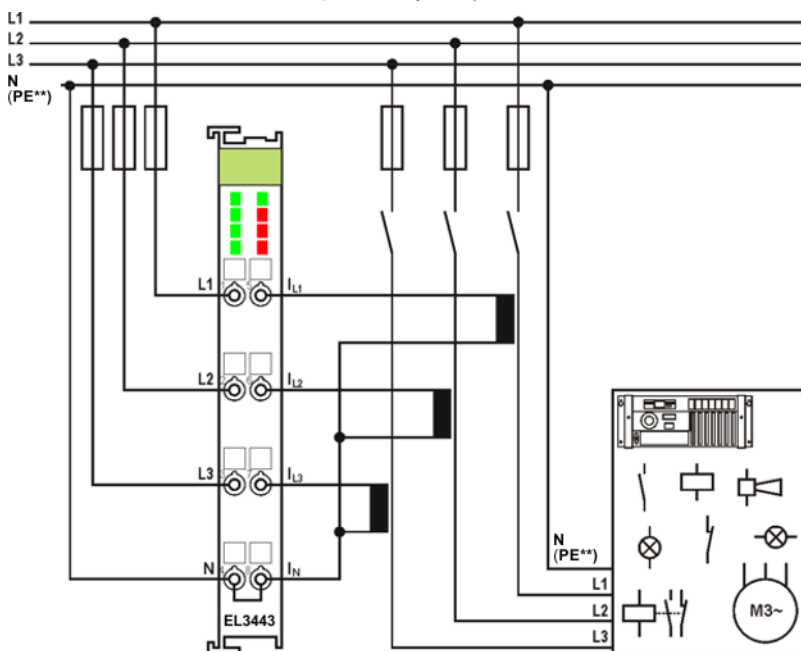

Fig. 20: EL3443, power measurement at a machine

**● Fuse protection of the terminal**

**i** The voltage measurement inputs L1 - L3 are high-impedance; a minimum measurement current flows. The fuses to the connection points L1 - L3 are therefore only to be designed according to the connection cross-section.

For the current measurement inputs  $I_{L1}$  -  $I_{L2}$ , the fuse protection must be adapted according to the device to be measured.

The secondary currents of the transformers are not fused, see figure.

**● \*\*) PE as star point for 3-phase systems without neutral line**

**i** Depending on the current transformers used, PE must be connected as star point in 3-phase systems without neutral line as shown in Fig. "EL3443, power measurement at a machine".

Observe the regulations of the manufacturer of the current transformers!

### ● Negative power values



If negative power values are measured on a circuit, please check whether the associated current transformer circuit is connected correctly.

#### EL3453

- The voltage is measured via connections L1, L2, L3 and N.
- The current is measured via 4 current transformers (e.g. from the Beckhoff SCT series) and the connections  $I_{L1}$ ,  $I_{L2}$ ,  $I_{L3}$  and  $I_N$  (star point of the current transformers).

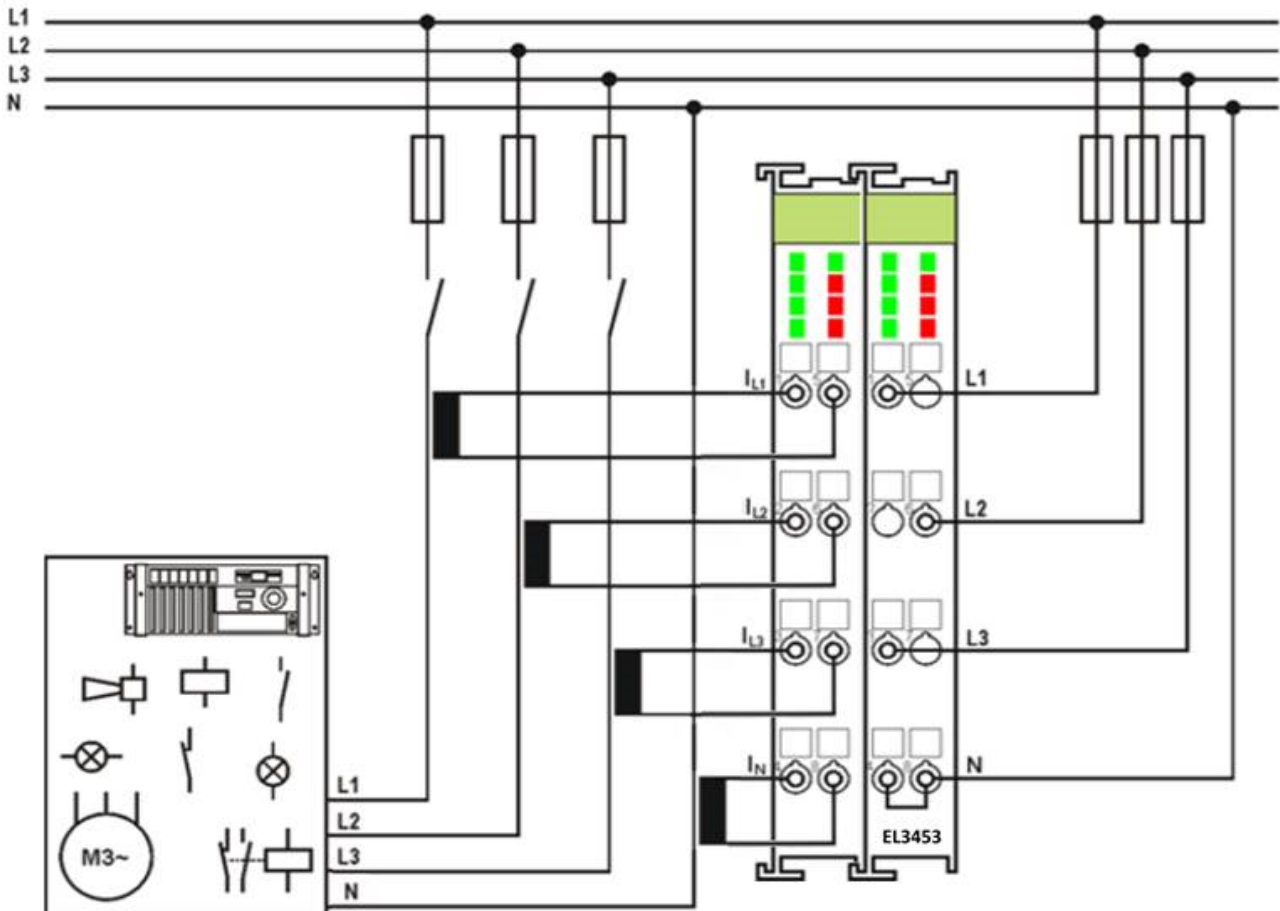

Fig. 21: EL3453, power measurement at a machine

### ● Negative power values



If negative power values are measured on a circuit, please check whether the associated current transformer circuit is connected correctly.

## 6 Appendix

### 6.1 Documentation issue status

Version	Comment
1.5	- Chapter "Technical data" updated - Update structure
1.4	- Chapter "Technical data" updated
1.3	- Chapter "Introduction" updated - Chapter "Technical data" updated
1.2	- Addenda chapter "Notes on class accuracy SCT transformers"
1.1	- Addenda & corrections
1.0	- 1 <sup>st</sup> public issue - Addenda & corrections

## 6.2 UL notes

### "Conditions of Acceptability" for SCT1xxx

---



#### Conditions of Acceptability

- These devices shall be installed within equipment that will provide an acceptable enclosure.
  - The acceptability of the mounting means for these transformers shall be determined in the end-use application.
  - These devices have not been tested for radio influence voltage (RIV), Accuracy and Mechanical Tests; Only Temperature tests at 60 Hz and Dielectric Voltage-Withstand tests have been conducted.
  - These devices employ Class 105 (A) Insulation Systems.
  - The suitability of the terminal blocks shall be considered in the end product.
  - Based on the temperature test results, the transformers may be classified as 55°C rise type at 55°C ambient
-



## 6.3 Support and Service

Beckhoff and their partners around the world offer comprehensive support and service, making available fast and competent assistance with all questions related to Beckhoff products and system solutions.

### Beckhoff's branch offices and representatives

Please contact your Beckhoff branch office or representative for local support and service on Beckhoff products!

The addresses of Beckhoff's branch offices and representatives round the world can be found on her internet pages: [www.beckhoff.com](http://www.beckhoff.com)

You will also find further documentation for Beckhoff components there.

### Support

The Beckhoff Support offers you comprehensive technical assistance, helping you not only with the application of individual Beckhoff products, but also with other, wide-ranging services:

- support
- design, programming and commissioning of complex automation systems
- and extensive training program for Beckhoff system components

Hotline: +49 5246 963 157  
e-mail: [support@beckhoff.com](mailto:support@beckhoff.com)  
web: [www.beckhoff.com/support](http://www.beckhoff.com/support)

### Service

The Beckhoff Service Center supports you in all matters of after-sales service:

- on-site service
- repair service
- spare parts service
- hotline service

Hotline: +49 5246 963 460  
e-mail: [service@beckhoff.com](mailto:service@beckhoff.com)  
web: [www.beckhoff.com/service](http://www.beckhoff.com/service)

### Headquarters Germany

Beckhoff Automation GmbH & Co. KG

Hülshorstweg 20  
33415 Verl  
Germany

Phone: +49 5246 963 0  
e-mail: [info@beckhoff.com](mailto:info@beckhoff.com)  
web: [www.beckhoff.com](http://www.beckhoff.com)



More Information:  
[www.beckhoff.com/SCT1xxx](http://www.beckhoff.com/SCT1xxx)

Beckhoff Automation GmbH & Co. KG  
Hülshorstweg 20  
33415 Verl  
Germany  
Phone: +49 5246 9630  
[info@beckhoff.com](mailto:info@beckhoff.com)  
[www.beckhoff.com](http://www.beckhoff.com)

