

Documentation | EN

PS3031-4820-0000

Power supply 48 V DC, 20 A, 3-phase



Table of contents

1 Overview	5
2 Foreword	6
2.1 Notes on the documentation	6
2.2 Safety instructions	7
2.3 Terminology and abbreviations	9
3 Technical data, mounting, wiring	10
3.1 AC input	10
3.2 DC input	11
3.3 Input inrush current	11
3.4 Output	12
3.5 Hold-up time	15
3.6 DC-OK relay contact	16
3.7 Shutdown input	17
3.8 Output voltage control	17
3.9 Efficiency and losses	18
3.10 Lifetime expectancy and MTBF	20
3.11 Terminals and wiring	21
3.12 Functional wiring diagram	22
3.13 Front side and operating elements	23
3.14 EMC	25
3.15 Environment	26
3.16 Protective functions	27
3.17 Safety features	27
3.18 Dielectric strength	28
3.19 Declaration of conformity and approvals	29
3.20 Dimensions and weight	30
4 Application notes	31
4.1 Repeated pulse load	31
4.2 Peak current capability	33
4.3 External input protection	34
4.4 Operation on two phases of a 3-phase system	35
4.5 Output circuit breakers	36
4.6 Charging batteries	37
4.7 Series connection	37
4.8 Parallel use to increase power	38
4.9 Parallel use for redundancy	39
4.9.1 1+1 Redundancy	39
4.9.2 N+1 Redundancy	40
4.10 Inductive and capacitive loads	40
4.11 Back-feeding loads	40
4.12 Use in a tightly sealed enclosure	40
4.13 Installation positions	41
5 Disposal	43

6 Appendix	44
6.1 Accessories	44
6.1.1 Redundancy and buffer modules	44
6.1.2 Mounting accessories	44
6.2 Documentation issue status	45
6.3 Support and Service.....	46

1 Overview

PS3031-4820-0000 | Power supply 48 V, 20 A, 3-phase



- 3AC 380-480 V wide-range input
- Three built-in input fuses
- 95.4% full load and excellent part-load efficiencies
- Width only 110 mm, weight only 1.5 kg
- 150% peak power, 1440 W for up to 4 s
- 55 A peak current over 25 ms for triggering fuses
- Active power factor correction (PFC)
- Active filtering of input transients
- Negligible input inrush current surge
- Full power between -25°C and +60°C
- Option of current sharing for parallel connection
- Controllable output voltage level
- DC-OK relay contact
- Shutdown input

The PS3031-4820-0000 is a 3-phase 48 V power supply with an output current of 20 A and an output power of 960 W.

On the input side, the device features a wide-range input, active power factor correction (PFC) and inrush current limiting.

The PS3031-4820-0000 features an Extra Power output with a maximum output power of 150% over 4 seconds and is able to trigger fuses precisely with a short-term peak current. A DC-OK LED, an overload LED and a potential-free relay contact monitor the status of the output voltage. The output voltage can be switched off by means of the shutdown contact.

The power supply is part of the PS3000 family and has a width of 110 mm.

Overview of technical data *)

Overview of technical data	PS3031-4820-0000
Output voltage	DC 48 V (nominal)
Adjustment range	48 - 54 V
Output current	20 - 17.8 A (continuous); 30 - 26.7 A (short-term for 4 s)
Output power	960 W (continuous); 1440 W (short-term for 4 s)
Output ripple	< 150 mVpp (20 Hz to 20 MHz)
Input voltage AC	3AC 380-480 V -15%/+20%
Mains frequency	50-60 Hz ±6%
Input current AC	1.65 / 1.35 A at 3 x 400 / 480 Vac
Power factor	0.88 / 0.90 at 3 x 400 / 480 Vac
Inrush current surge AC	typ. 4.5 A peak
Efficiency	95.4 / 95.2% at 3 x 400 / 480 Vac
Losses	46.3 / 48.4 W at 3 x 400 / 480 Vac
Operating temperature range	-25°C to +70°C
Derating	24 W / °C (+60°C to +70°C)
Hold-up time	Typ. 25 / 25 ms at 3 x 400 / 480 Vac
Dimensions (W x H x D)	110 x 124 x 127 mm (without DIN rail)
Weight	1500 g
Approvals/markings	CE, UKCA, cULus, EAC

*) All values typical for 48 V, 20 A, 3x 400 Vac, 25 °C ambient temperature and after a warm-up time of 5 minutes, unless otherwise stated.

2 Foreword

2.1 Notes on the documentation

Copyright

© Beckhoff Automation GmbH & Co. KG, Germany.

The reproduction, distribution and utilization of this document as well as the communication of its contents to others without express authorization are prohibited.

Offenders will be held liable for the payment of damages. All rights reserved in the event of the grant of a patent, utility model or design.

Disclaimer

The documentation has been prepared with care. The products described are, however, constantly under development.

We reserve the right to revise and change the documentation at any time and without prior announcement.

No claims for the modification of products that have already been supplied may be made on the basis of the data, diagrams and descriptions in this documentation.

Trademarks

Beckhoff®, TwinCAT®, TwinCAT/BSD®, TC/BSD®, EtherCAT®, EtherCAT G®, EtherCAT G10®, EtherCAT P®, Safety over EtherCAT®, TwinSAFE®, XFC®, XTS® and XPlanar® are registered trademarks of and licensed by Beckhoff Automation GmbH. Other designations used in this publication may be trademarks whose use by third parties for their own purposes could violate the rights of the owners.

Patent Pending

The EtherCAT Technology is covered, including but not limited to the following patent applications and patents: EP1590927, EP1789857, EP1456722, EP2137893, DE102015105702 with corresponding applications or registrations in various other countries.

Intended audience

This description is only intended for the use of trained specialists in control and automation engineering who are familiar with the applicable national standards.

It is essential that the documentation and the following notes and explanations are followed when installing and commissioning these components.

It is the duty of the technical personnel to use the documentation published at the respective time of each installation and commissioning.

The responsible staff must ensure that the application or use of the products described satisfy all the requirements for safety, including all the relevant laws, regulations, guidelines and standards.

2.2 Safety instructions

Description of instructions

In this documentation the following instructions are used.
These instructions must be read carefully and followed without fail!

DANGER

Serious risk of injury!

Failure to follow this safety instruction directly endangers the life and health of persons.

WARNING

Risk of injury!

Failure to follow this safety instruction endangers the life and health of persons.

CAUTION

Personal injuries!

Failure to follow this safety instruction can lead to injuries to persons.

NOTICE

Damage to environment/equipment or data loss

Failure to follow this instruction can lead to environmental damage, equipment damage or data loss.



Tip or pointer

This symbol indicates information that contributes to better understanding.

Intended use

This device is designed for installation in a housing and is intended for general professional use, for example in industrial control systems or office, communication and measuring equipment.

Do not use this power supply in installations where a malfunction could cause serious injury or danger to human life.

Exclusion of liability

All the components are supplied in particular hardware and software configurations appropriate for the application. Modifications to hardware or software configurations other than those described in the documentation are not permitted, and nullify the liability of Beckhoff Automation GmbH & Co. KG.

Personnel qualification

This description is only intended for trained specialists in control, automation and drive engineering who are familiar with the applicable national standards.

Safety regulations

Please note the following safety instructions and explanations!
Product-specific safety instructions can be found on following pages or in the areas mounting, wiring, commissioning etc.



Safety instructions and installation requirements for the PS3031-4820-0001 power supply**⚠ DANGER****Danger of electric shock, fire, injuries, injuries resulting in death!**

- Do not use the power supply without proper grounding (protective conductor). Use the terminal at the input terminal strip for the earth connection, not one of the screws on the housing.
- Switch off the power supply before working on the device. Provide protection against unintentional reconnection.
- Ensure proper wiring by following all local and national regulations.
- Do not modify or attempt to repair the device.
- Do not open the device, as high voltages are present inside.
- Avoid foreign bodies entering the housing.
- Do not use the device in damp locations or in areas where moisture or condensation is likely to occur.
- Do not touch the device when it is switched on or immediately after it has been switched off. Hot surfaces can cause burns.

● Further notes on installation requirements**i**

- This device contains no serviceable parts.
- Triggering of an internal fuse indicates an internal defect.
- In the event of damage or malfunction during installation or operation, switch off the device immediately and return it to the factory for inspection.
- Mount the device on a DIN rail so that the input and output terminals are at the bottom of the device. For other mounting orientations, please refer to the derating requirements in chapter [Mounting positions](#) [▶ 41].
- This device is designed for convection cooling and does not require an external fan. Do not obstruct the air flow and do not cover the ventilation grille (e.g., cable ducts) by more than 15%!
- Maintain the following installation distances: 40 mm at the top, 20 mm at the bottom and 5 mm on the left and right are recommended if the device continuously runs at more than 50% of the rated output. Increase this distance to 15 mm if the adjacent device is a heat source (e.g., another power supply).

2.3 Terminology and abbreviations

PE and the earthing symbol 	PE is the abbreviation for "protective earth" and has the same meaning as the earthing symbol 
Earth, ground	The terms earth and ground are synonymous and are used interchangeably in this document.
T.b.d.	Still to be defined, value or description will follow in due course.
AC 400 V	A value preceded by "AC" or "DC" represents a nominal voltage or a nominal voltage range. The nominal voltage or the nominal voltage range may be provided with tolerances. (e.g., AC 380 - 480 V \pm 15%). The calculated total range then indicates the working range of the device. Example: DC 12 V refers to a 12 V battery, regardless of whether it is fully charged (13.7 Vdc) or discharged (10 Vdc).
400 Vac	A value followed by the unit Vac or Vdc is an instantaneous value that does not contain any additional tolerances.
50 Hz vs. 60 Hz	Unless otherwise specified, AC 230 V parameters are valid at a mains frequency of 50 Hz.
may	A keyword indicating a choice without implied preference.
shall	A keyword indicating a mandatory requirement.
should	A keyword indicating a choice with a clearly preferred method of implementation.

3 Technical data, mounting, wiring

3.1 AC input

AC input			
AC input	Nom.	3AC 380 - 480 V	Wide-range input
AC input range	Min.	3x 323 - 576 Vac	Continuous operation
Suitable mains systems		TN, TT, IT	Grounding of one phase is permitted, except for UL 508 applications
Permissible voltage L to earth	Max.	576 Vac	Continuous according to IEC 60664-1
Input frequency	Nom.	50 - 60 Hz	±6%
Turn-on voltage	Typ.	3x 305 Vac	Static, load-independent, see Fig. <i>Input voltage range; switch-on behavior definitions</i>
Shut-down voltage	Typ.	3x 275 Vac	Static, load-independent, see Fig. <i>Input voltage range; switch-on behavior definitions</i>

AC input		3AC 400 V	3AC 480 V	
Input current	Typ.	1.65 A	1.35 A	At 48 V, 20 A per phase, see Fig. <i>Input current over output current; power factor over output current</i>
Power factor*)	Typ.	0.88	0.90	At 48 V, 20 A, see Fig. <i>Input current over output current; power factor over output current</i>
Start-up delay	Typ.	500 ms	600 ms	See Fig. <i>Input voltage range; switch-on behavior definitions</i>
Rise time	Typ.	23 ms	23 ms	At 48 V, 20 A, ohmic load only, 0 mF, see Fig. <i>Input voltage range; switch-on behavior definitions</i>
	Typ.	47 ms	47 ms	At 48 V, 20 A ohmic load with an additional 20 mF capacitor, see Fig. <i>Input voltage range; switch-on behavior definitions</i>
Turn-on overshoot	Max.	1 V	1 V	See Fig. <i>Input voltage range; switch-on behavior definitions</i>

*) The power factor is the ratio of real (or active) power to apparent power in an AC circuit.

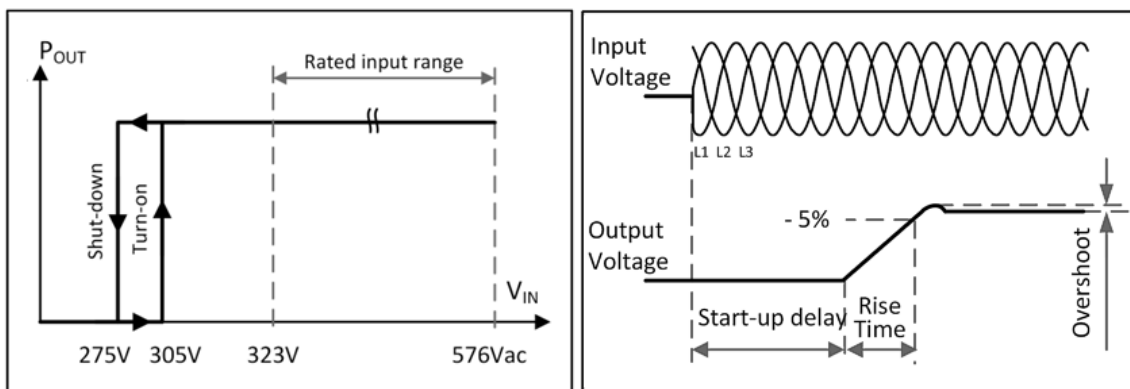

Fig. 1: Input voltage range; switch-on behavior definitions

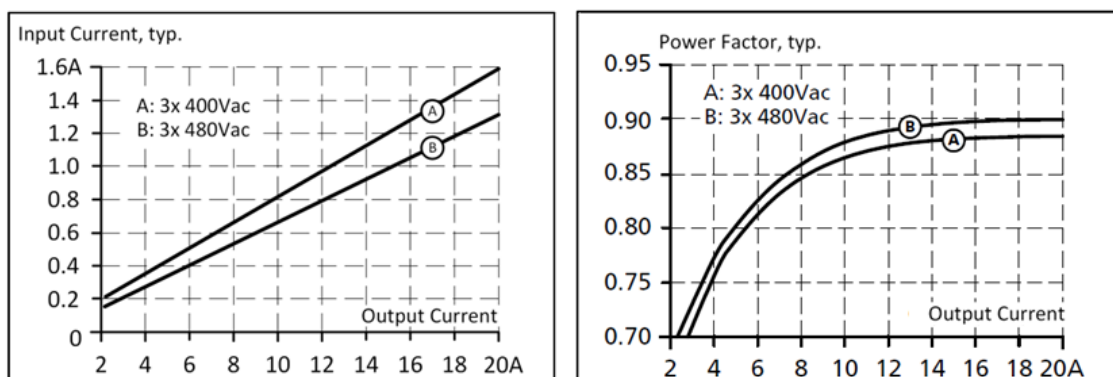

Fig. 2: Input current over output current; power factor over output current

3.2 DC input

Do not use the power supply unit with DC input voltages!

3.3 Input inrush current

The power supply is equipped with an active inrush current limiting circuit that limits the input inrush current to a very low value after power-up and after short interruptions of the input voltage.

		3AC 400 V	3AC 480 V	
Input inrush current*	Max.	6 A peak	6 A peak	temperature-independent
	Typ.	4.5 A peak	4.5 A peak	
Inrush energy	Max.	1.5 A ² s	1.5 A ² s	
Start-up delay	Typ.	500 ms	600 ms	

* The charge current of the interference suppression capacitors during the first few microseconds after switching on is not taken into account.

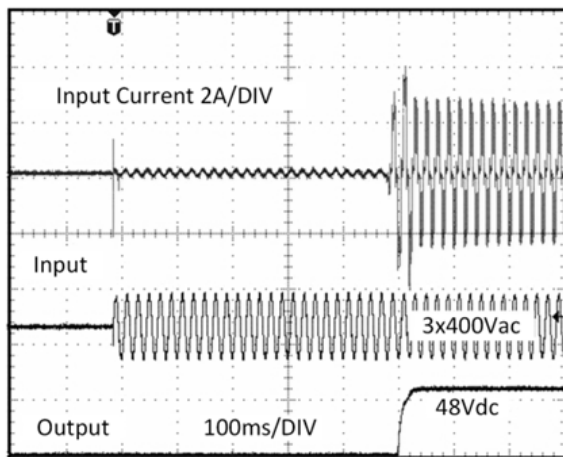

Fig. 3: Typical switch-on behavior at nominal load, 25°C ambient temperature

3.4 Output

Output			
Output voltage	Nom.	DC 48 V	
Adjustment range	Min.	48 - 54 Vdc	Guaranteed value
	Max.	56 Vdc	This is the maximum output voltage that can occur in the end position of the potentiometer in clockwise direction due to tolerances. It is not a guaranteed value that can be achieved. A typical value is 55 V.
Factory settings	Typ.	48.0 Vdc	±0.2%, at full load (cold device), in "Single Use" mode
	Typ.	46.0 Vdc	±0.2%, at full load (cold device), in "Parallel Use" mode
	Typ.	48.0 Vdc	At idle, cold device, in "Parallel Use" mode
Line regulation	Max.	10 mV	3 x 323 - 576 Vac
Load regulation	Max.	50 mV	In "Single Use" mode: between 0 and 20 A, static value, see Fig. <i>Output voltage over output current typ. in "Single Use" mode</i> ,
	Typ.	2000 mV	In "Parallel Use" mode: between 0 and 20 A, static value, see Fig. <i>Output voltage over output current typ. in "Parallel Use" mode</i> ,
Residual ripple and ripple voltage	Max.	150 mV _{SS}	Bandwidth 20 Hz to 20 MHz, 50 ohm
Output current - continuous	Nom.	20 A	At 48 V, see Fig. <i>Output voltage over output current typ. in "Single Use" mode</i> ; <i>output voltage over output current typ. in "Parallel Use" mode</i>
	Nom.	17.8 A	At 54 V, see Fig. <i>Output voltage over output current typ. in "Single Use" mode</i> ; <i>output voltage over output current typ. in "Parallel Use" mode</i>
Output current - Extra power up to 4 s ¹⁾	Nom.	30 A	At 48 V, see Fig. <i>Output voltage over output current typ. in "Single Use" mode</i> ; <i>output voltage over output current typ. in "Parallel Use" mode</i> and Fig. <i>Dynamic overcurrent capability, typ. < 10 ms</i> ; <i>Dynamic overcurrent capability, typ. < 25 ms</i>
	Nom.	26.7 A	At 54 V, see Fig. <i>Output voltage over output current typ. in "Single Use" mode</i> ; <i>output voltage over output current typ. in "Parallel Use" mode</i> and Fig. <i>Dynamic overcurrent capability, typ. < 10 ms</i> ; <i>Dynamic overcurrent capability, typ. < 25 ms</i>
Output current	Typ.	55 A	up to 25 ms, output voltage remains above 40 V, see Fig. <i>Dynamic overcurrent capability, typ. < 10 ms</i> ; <i>Dynamic overcurrent capability, typ. < 25 ms</i> This peak current is available once per second. for further peak current measurements see chapter Peak current capability [► 33]
Output power - continuous	Nom.	960 W	At 48 - 54 V
Output power - Extra Power 4 s ¹⁾	Nom.	1440 W	At 48 - 54 V
Extra power time (bonus time)	Typ.	4 s	Time until the output voltage drops, see Fig. <i>Bonus time over output power</i>
Recovery time	Typ.	7 s	Overload-free time until the power manager is reset, see Fig. <i>Extra power recovery time</i>
Overload behavior		Continuous current	See Fig. <i>Output voltage over output current</i>
Short-circuit current ²⁾	Min.	20 A	Continuous, load impedance 50 mOhm, see Fig. <i>Output voltage over output current, typ. in "Single Use" mode</i>
	Max.	22 A	Continuous, load impedance 50 mOhm, see Fig. <i>Output voltage over output current, typ. in "Single Use" mode</i>
	Min.	30 A	Short term for 4 s, load impedance 50 mOhm, see Fig. <i>Output voltage over output current, typ. in "Single Use" mode</i>
	Max.	34 A	Short term for 4 s, load impedance 50 mOhm, see Fig. <i>Output voltage over output current, typ. in "Single Use" mode</i>
	Typ.	26 A	Continuous, load impedance < 10 mOhm
	max	29 A	Continuous, load impedance < 10 mOhm
Output capacity	Typ.	3,700 µF	Included in the power supply

¹⁾ **Extra power**

The power supply is designed to support loads with higher short-term power requirements without damage or shutdown.

The short-time duration/bonus time is controlled in hardware by an output power manager.

Extra power is available repeatedly. Detailed information can be found in the chapter on [Repeated pulse load](#) [► 31].

If the power supply is subjected to extra power for longer than shown in the bonus time diagram (see Fig. [Bonus time over output power](#) [► 13]), the maximum output power is automatically reduced to 960 W.

²⁾ The discharge current of the output capacitors is not included.

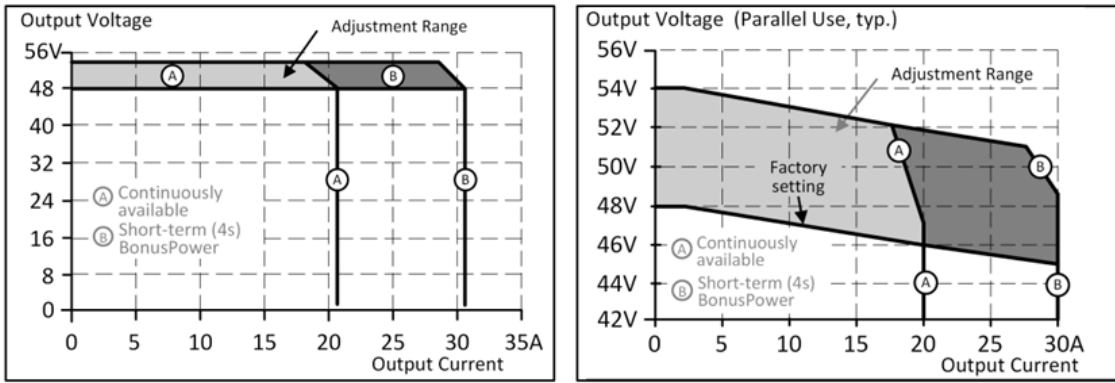

Fig. 4: Output voltage over output current typ. in "Single Use" mode; output voltage over output current typ. in "Parallel Use" mode

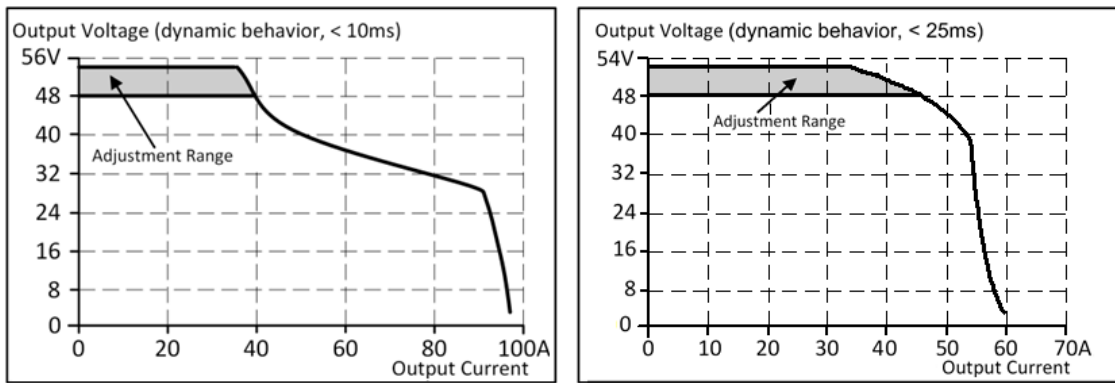

Fig. 5: Dynamic overcurrent capacity, typ. <math>< 10\text{ms}</math>; Dynamic overcurrent capacity, typ. <math>< 25\text{ms}</math>

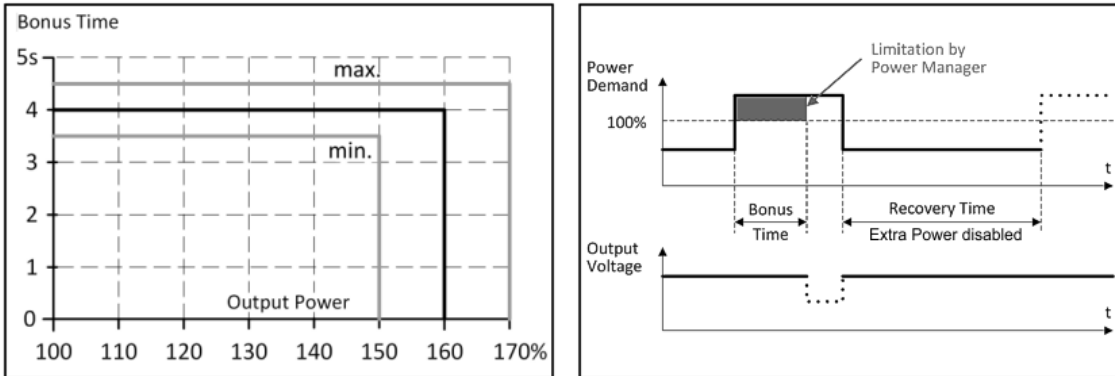

Fig. 6: Bonus time over output power; Extra power recovery time

Extra power is available as soon as the power is turned on and after an output short-circuit or output overload.

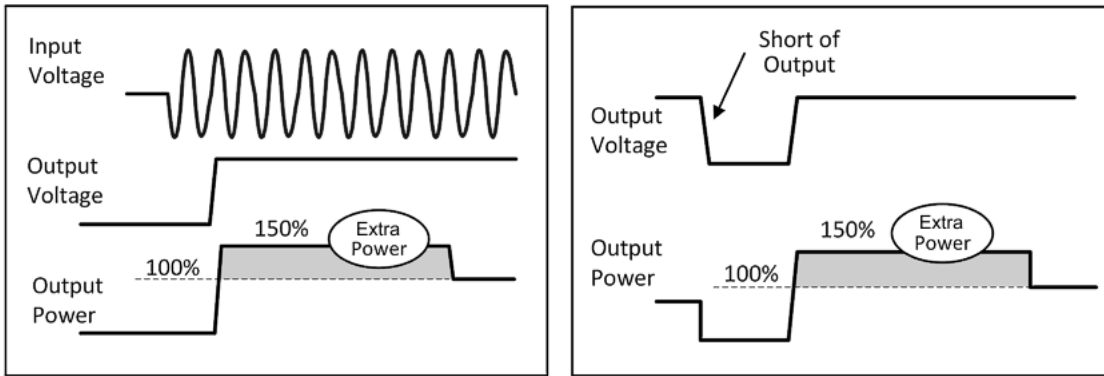

Fig. 7: Extra power after switching on; extra power after short circuit or overload

3.5 Hold-up time

		3AC 400 V ¹⁾	3AC 480 V ¹⁾	
Hold-up time	Typ.	50 ms	50 ms	At 48 V, 10 A, see Fig. <i>Hold-up time over input voltage</i>
	Min.	40 ms	40 ms	At 48 V, 10 A, see Fig. <i>Hold-up time over input voltage</i>
	Typ.	25 ms	25 ms	At 48 V, 20 A, see Fig. <i>Hold-up time over input voltage</i>
	Min.	20 ms	20 ms	At 48 V, 20 A, see Fig. <i>Hold-up time over input voltage</i>

¹⁾ Characteristic curves and figures for operation on only two external conductors of a 3-phase system can be found in chapter Operation on two phases of a 3-phase system [▶ 35].

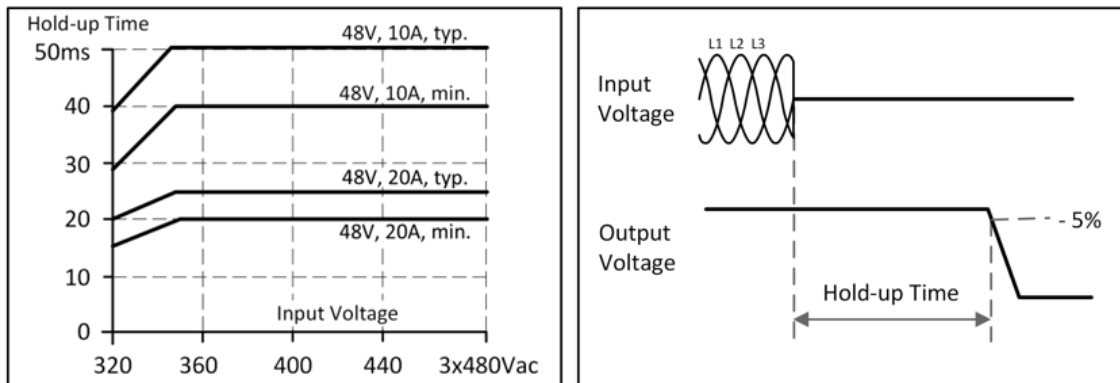

Fig. 8: Hold-up time over input voltage; switch-off behavior, definitions

3.6 DC-OK relay contact

This function monitors the output voltage generated by the power supply itself. It is independent of a voltage fed back from a unit connected in parallel to the power supply output.

The contact closes	when the output voltage reaches 90% of the set output voltage.
The contact opens	when the output voltage drops more than 10% below the set output voltage. Short bursts are extended to a signal length of 250 ms. Drops that are shorter than 1 ms are ignored.
The contact closes again	when the output voltage exceeds 90% of the set voltage.
Contact load capacity	Maximum 60 Vdc 0.3 A, 30 Vdc 1 A, 30 Vac 0.5 A, ohmic load Minimum permissible load: 1 mA at 5 Vdc
Insulation voltage	See the table in chapter Dielectric strength [► 28]

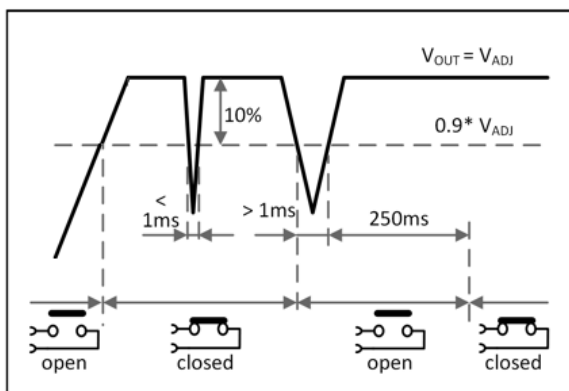

Fig. 9: Behavior of the DC-OK relay contact

● Nature and source of the danger

i The DC-OK function requires the output voltage to reach the rated (=set) level after power-up in order to function as specified.

- If this level is not reached, the overload LED lights up and the DC-OK contact opens. The overload LED goes out when the set voltage is reached.
- ⇒ This is an important condition to be considered especially if the load is a battery, the power supply is used in parallel or the power supply is used for N+1 redundant systems.

3.7 Shutdown input

The shutdown input allows the output of the power supply to be switched off by means of a signal switch or external voltage.

- The shutdown takes place without delay, while switching on is delayed by up to 350 ms.
- When switched off, the output voltage is less than 4 V and the output power is less than 0.5 W.
- When units are connected in parallel, the voltage difference between the various negative output terminals must be less than 1 V.
- When operating several power supplies in series, only wiring option "A" with single signal switches is permitted.

i **Information regarding the use of the shutdown input**

Please note the following:

- Option C (see diagram below) requires current reduction capability of the voltage source. Do not use a blocking diode!
- The shutdown function does not include any safety functionality

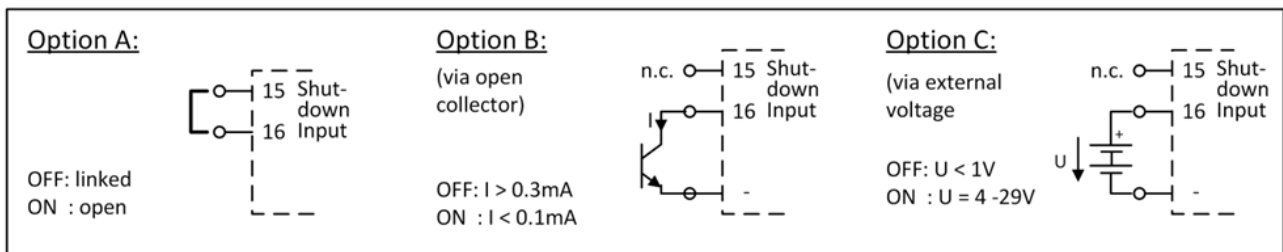

Fig. 10: Activation of the shutdown input

3.8 Output voltage control

The shutdown input can also be used to remotely adjust the output voltage between typically 44 Vdc and 54 Vdc. All other functions of the shutdown input remain the same.

The control voltage is relative to the ground of the 48 V output terminal (negative output voltage).

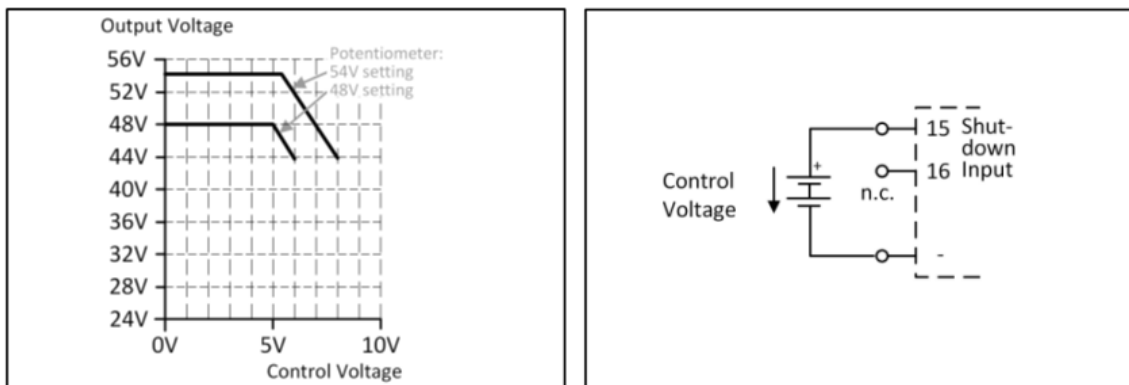

Fig. 11: Remote control of the output voltage; applying the control voltage

Instructions:

1. Set the unit to "Single Use" mode.
2. Set the output voltage (48 - 54 V) to the maximum required voltage.
3. Apply a control voltage to reduce the output voltage.

3.9 Efficiency and losses

Efficiency for 3-phase operation:

		3AC 400 V	3AC 480 V	
Efficiency	Typ.	95.4%	95.2%	At 48 V, 20 A
Average efficiency ¹⁾	Typ.	94.7%	94.6%	25% at 5 A, 25% at 10 A, 25% at 15 A. 25% at 20 A
Losses	Typ.	1.5 W	1.5 W	If switch-off is activated
	Typ.	9.5 W	9.8 W	At 48 V, 0 A, (no load)
	Typ.	24.1 W	25.0 W	At 48 V, 10 A, (half load)
	Typ.	46.3 W	48.4 W	At 48 V, 20 A, (full load)

¹⁾ The average efficiency is based on assumptions for a typical application with a power supply load of 25% of the nominal load for 25% of the time, 50% of the nominal load for 25% of the time, 75% of the nominal load for 25% of the time and 100% of the nominal load during the remaining time.

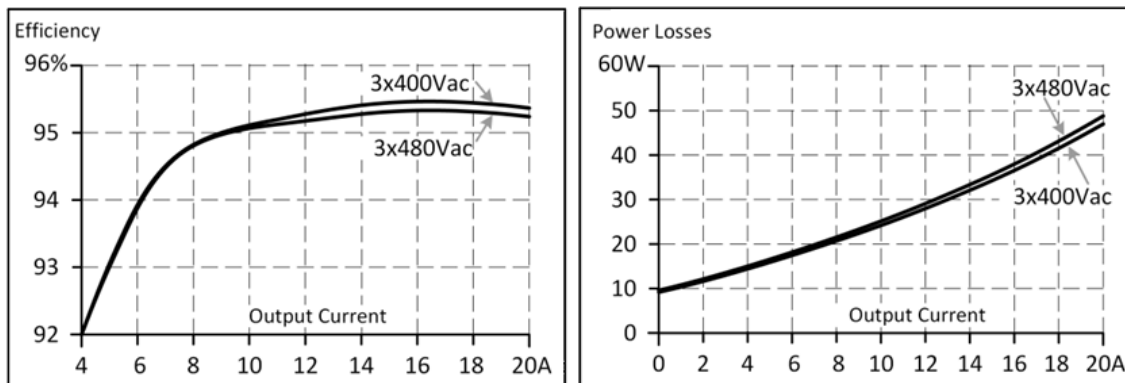

Fig. 12: Efficiency over output current; losses over output current

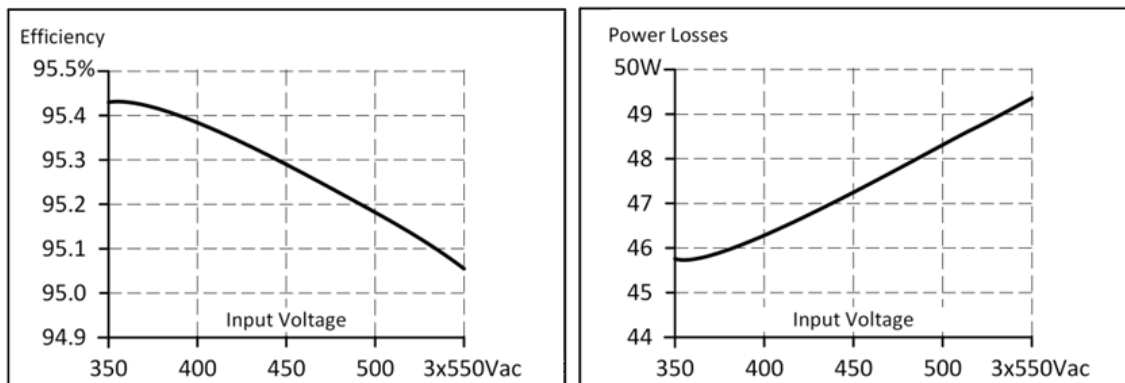



Fig. 13: Efficiency over input voltage; losses over input voltage

Efficiency when using only two phases of a 3-phase system:

NOTICE				
	Operation on two phases of a 3-phase system			
	Please note the information in chapter Operation on two phases of a 3-phase system ▶ 35!			

		2AC 400 V	2AC 480 V	
Efficiency	Typ.	94.4%	94.7%	At 48 V, 20 A
Losses	Typ.	56.9%	53.7%	At 48 V, 20 A (full load)

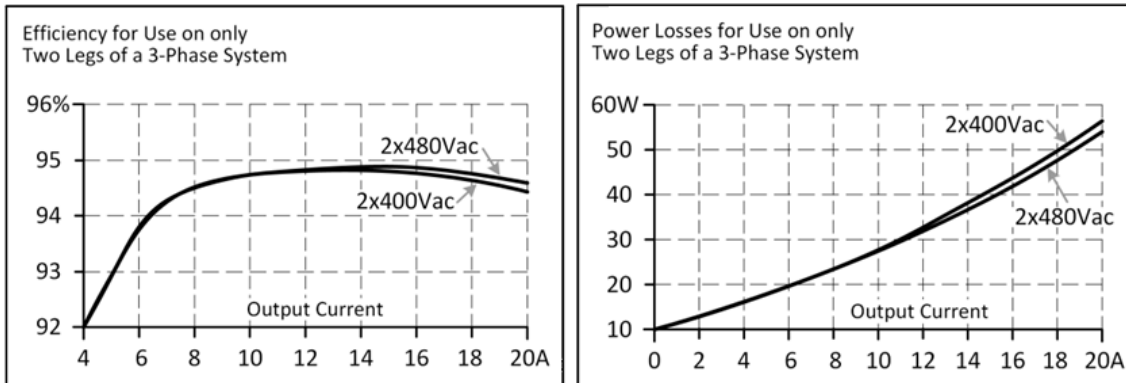

Fig. 14: Efficiency over output current at 48 V; losses over output current at 48 V

3.10 Lifetime expectancy and MTBF

	3AC 400 V	3AC 480 V	
Calculated lifetime expectancy ¹⁾	324,000 h ¹⁾	316,000 h ¹⁾	At 48 V, 10 A and +25°C
	115,000 h	112,000 h	At 48 V, 10 A and +40°C
	192,000 h ¹⁾	192,000 h ¹⁾	At 48 V, 20 A and +25°C
	86,000 h	86,000 h	At 48 V, 20 A and +40°C
MTBF ²⁾ SN 29500, IEC 61709	375,000 h	369,000 h	At 48 V, 20 A and +40°C
	685,000 h	678,000 h	At 48 V, 20 A and +25°C
MTBF ²⁾ MIL HDBK 217F	158,000 h	157,000 h	At 48 V, 20 A and +40°C, Ground Benign GB40
	211,000 h	210,000 h	At 48 V, 20 A and +25°C, Ground Benign GB25

¹⁾The **calculated lifetime expectancy** shown in the table indicates the minimum number of operating hours (service life) and is determined by the lifetime expectancy of the built-in electrolytic capacitors. The lifetime expectancy is stated in operating hours and is calculated according to the specifications of the capacitor manufacturer. The manufacturer of the electrolytic capacitors only guarantees a maximum service life of up to 15 years (131,400 h). Any number exceeding this value represents a calculated theoretical service life which can be used to compare devices.

²⁾ **MTBF** stands for **Mean Time Between Failure**, which is calculated on the basis of statistical equipment failures and indicates the reliability of a device. It is the statistical representation of the probability of failure of a device and does not necessarily represent the service life of a product. The MTBF number is a statistical representation of the failure probability of a device. For example, an MTBF number of 1,000,000 h means that statistically, if 10,000 devices are installed in the field, one device will fail every 100 hours. However, it is not possible to determine whether the failed device has run for 50,000 hours or only 100 hours.

3.11 Terminals and wiring

The terminals are designed to be finger-safe according to IP20 and are suitable for field or factory wiring.

Technical data	Input	Output	DC-OK signal
Connection cross-section	e*: 0.5 - 6 mm ² f*: 0.5 - 4 mm ² a*: max. 4 mm ² (d<2.8 mm)	e*: 0.5 - 16 mm ² f*: 0.5 - 10 mm ² a*: max. 10 mm ² (d<5.2 mm)	e*: 0.15 - 1.5 mm ² f*: 0.15 - 1.5 mm ² a*: max. 1.5 mm ² (d<1.5 mm)
Connection cross-section (AWG)	e*: AWG 20-10 f*: AWG 20-10 a*: AWG 20-10 (d<2.8 mm)	e*: AWG 22-8 f*: AWG 22-8 a*: AWG 22-8 (d<5.2 mm)	e*: AWG 26-14 f*: AWG 26-14 a*: AWG 26-14 (d<1.5 mm)
Strip length	7 mm / 0.28 inch	12 mm / 0.5 inch	7 mm / 0.28 inch
Screwdriver	3.5 mm slotted screwdriver or Phillips screwdriver No. 2	3.5 mm or 5 mm slotted screwdriver or Phillips screwdriver No. 2	3.0 mm slotted screwdriver (to open the spring)
Recommended tightening torque	1 Nm, 9 lb.in	2.3 Nm, 20.5 lb.in	Not applicable

e* = solid wire
f* = stranded wire
a* = with ferrule

Wiring instructions:

- Use suitable copper cables that are designed for at least the following operating temperatures:
+60°C for ambient temperatures up to +45°C and
+75°C for ambient temperatures up to +60°C and
+90°C for ambient temperatures up to +70°C.
- Observe the national installation rules and regulations!
- Make sure that all single wires of a strand are connected to the terminal!
- Do not use the device without PE connection.
- Unused terminals should be tightened firmly.
- Ferrules are permitted.

Series connection of power supply units:

Series connection (looping from one power supply output to the next) is permitted as long as the average output current flowing through a connection pin does not exceed 54 A. For higher currents please use a separate distribution terminal strip as shown in Fig. *Using distribution terminals*.

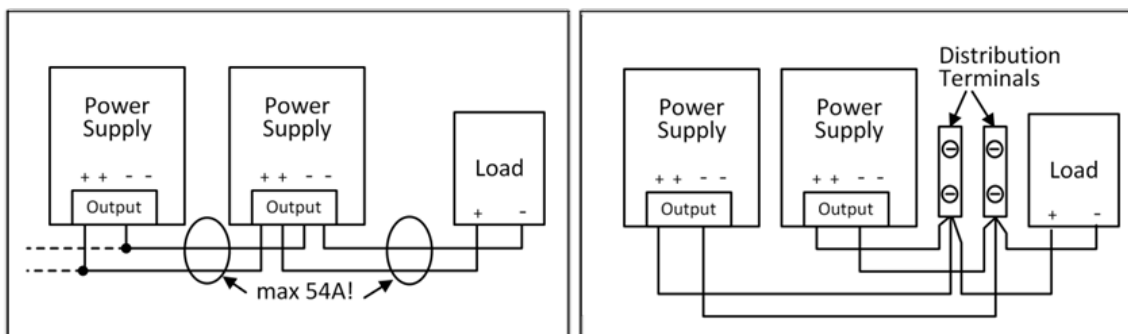

Fig. 15: Series connection of outputs; use of distribution terminals

3.12 Functional wiring diagram

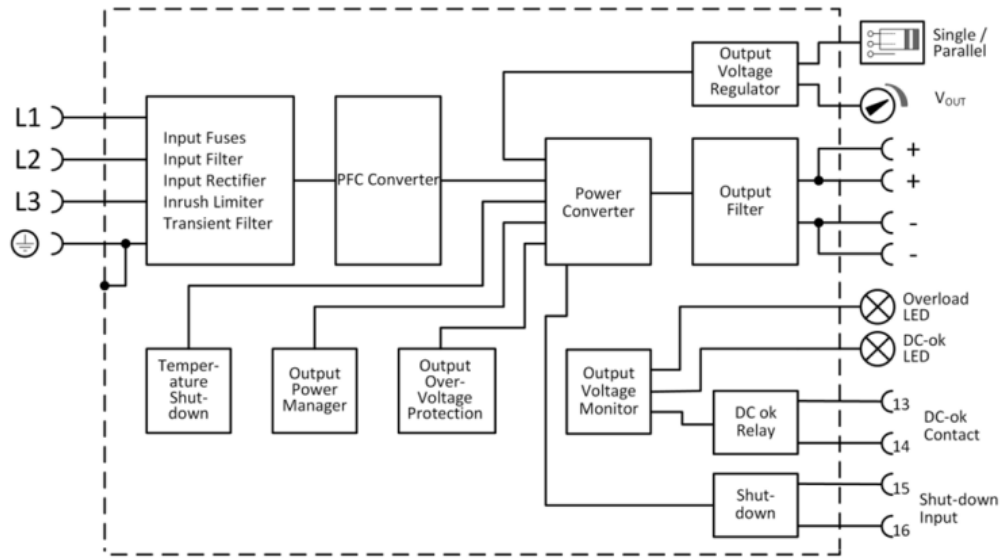

Fig. 16: Functional wiring diagram

3.13 Front side and operating elements

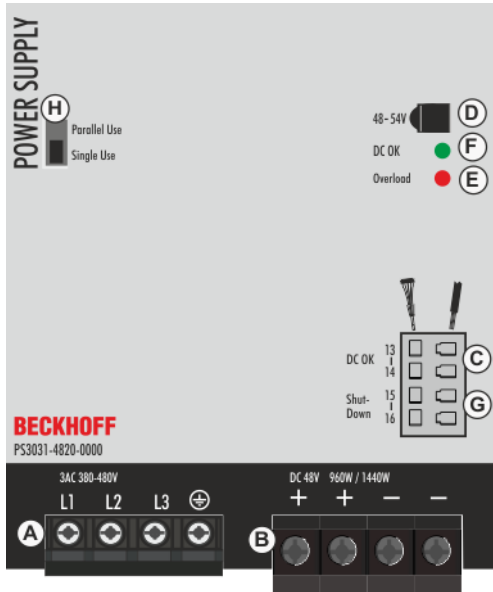



Fig. 17: PS3031-4820-0000, front

Input terminals (screw terminals)

Designation (A)	Description
L1, L2, L3	Mains input L1, L2, L3
	PE input (protective conductor)

Output terminals (screw terminals, two contact pins per pole)

Designation (B)	Description
+	two identical positive poles, positive output
-	two identical negative poles, negative output

DC-OK relay contact (spring-loaded terminals)

Designation (C)	Description
13 / 14 make contact	The DC-OK relay contact is synchronized with the DC-OK LED See chapter on DC OK relay contact [▶ 16] for more information.

Potentiometer for the output voltage

Designation (D)	Description
Potentiometer cover	Open the flap to adjust the output voltage. Factory setting: 48.0 V at rated output current, "Single Use" mode

Overload LED

Designation (E)	Description
LED red	On when the voltage at the output terminals is <90% of the set output voltage, or in the event of a short circuit in the output. Flashes when the switch-off has been activated or when the device has switched off due to overtemperature. The input voltage is always required.

DC-OK LED

Designation (F)	Description
LED green	On when the voltage at the output terminals is >90% of the set output voltage.

Shutdown input

Designation (G)	Description
Shutdown input	Input for shutdown and remote control Enables the power supply to be switched off. Can be activated by a switch contact or external voltage. The remote control input allows the output voltage to be set. For details see chapters DC-OK relay contact [16] and Shutdown input [17]

Selector switch for "Parallel Use" / "Single Use" mode

Designation (H)	Description
Selector switch for "Parallel Use" / "Single Use" mode	Set the jumper to "Parallel Use" mode if power supplies are connected in parallel to increase the output power. In order to distribute the load current between the individual power supplies, "Parallel Use" mode regulates the output voltage so that the idle voltage is approx. 4% higher than at nominal load. See also chapter "Parallel Use" for power increase [38]. A missing jumper corresponds to "Single Use" mode.

LED displays	Overload LED	DC-OK LED	DC-OK contact
Normal mode	OFF	ON	Closed
During extra power	OFF	ON	Closed
Overload ($V_{out} < 90\%$)	ON	OFF	Open
Short circuit at output	ON	OFF	Open
Temperature switch-off	flashes	OFF	Open
Shutdown input active	flashes	OFF	Open
No input power	OFF	OFF	Open

3.14 EMC

The power supply is suitable without any restrictions for application in industrial environments as well as in residential, commercial and light industrial areas and small businesses.

The device was tested according to EN 61000-6-1, EN 61000-6-2, EN 61000-6-3 and EN 61000-6-4.

EMC interference immunity			
Strong transients	VDE 0160	Over the entire load range	1550 V, 1.3 ms

EMC interference emission	According to the generic standards: EN 6100-6-3 and EN 6100-6-4		
Conducted interference emission, input lines	EN 55011, EN 55022, FCC Part 15, CISPR 11, CISPR 22	Class B	
Conducted interference emission, output lines	IEC/CISPR 16-1-2, IEC/CISPR 16-2-1	5 dB higher than the AV limit value curve for the DC power connection according to EN 61000-6-3 ¹⁾	
Interfering radiation	EN 55011, EN 55022	Class B	
Harmonic input current	EN 61000-3-2	Requirements for Class A devices met	
Voltage fluctuations, flicker	EN 61000-3-3	Requirements met ²⁾	
This device complies with FCC Part 15.			
Operation is subject to the following two conditions:			
<ul style="list-style-type: none"> • This device must not cause adverse interference, and • This device must tolerate any interference it is subjected to, including interference that may cause undesired operation. 			

¹⁾ Restrictions apply to residential, commercial and light industrial applications as well as to small businesses involving local DC networks according to EN 61000-6-3. No restrictions for all types of industrial applications.

²⁾ Tested with constant current loads, non-pulsating

3.15 Environment

Environment		
Operating temperature ¹⁾	-25°C to +70°C	Reduction of the output power according to Fig. <i>Output current over ambient temperature</i>
Storage temperature	-40°C to +85°C	For storage and transport
Output load reduction (derating)	24 W/°C	+60°C to +70°C
Humidity ²⁾	5 to 95% r.h.	According to IEC 60068-2-30
Oscillation, sinusoidal	2-17.8 Hz: ±1.6 mm; 17.8-500 Hz: 1 g 2 hours/axis	According to IEC 60068-2-6, Higher values are permissible when the wall-mounting bracket (ZS5301-0002) is used
Impact	15 g 6 ms, 10 g 11 ms 3 impacts/direction, 18 impacts in total	According to IEC 60068-2-27, Higher values are permissible when the wall-mounting bracket (ZS5301-0002) is used
Installation altitude	0 to 2000 m	Without restrictions
	2000 - 6000 m	Reduce the output power or the ambient temperature, see Fig. <i>Output current over installation altitude</i> IEC 62103, EN 50178, overvoltage category II
Derating, installation altitude	60 W/1000 m or 5°C/1000 m	> 2000 m, see Fig. <i>Output current over installation altitude</i>
Overvoltage category	III	According to IEC 62103, 50178, installation altitudes up to 2000 m
	II	Installation altitudes between 2000 m and 6000 m
Degree of pollution	2	According to IEC 62103, EN 50178, non-conductive
LABS-free	The device does not release any silicones or other paint-wetting impairment substances and is suitable for use in paint shops.	

¹⁾ The working temperature is identical to the room temperature or the ambient temperature and is defined as the air temperature 2 cm below the device.
Characteristic curves and figures for operation on two phases of a 3-phase system can be found in chapter [Operation on two phases of a 3-phase system \[► 35\]](#).

²⁾ Do not energize when condensation is present!

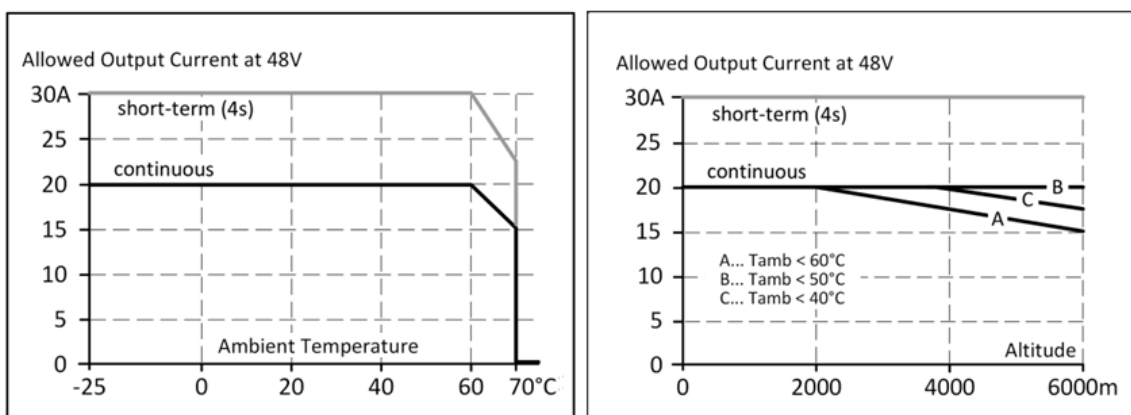

Fig. 18: Output current over ambient temperature; output current over installation altitude

3.16 Protective functions

Protective functions		
Output protection	Electronically protected against overload, no load and short circuits ¹⁾	
Output overvoltage protection	Typ. 58.5 Vdc Max. 60 Vdc	In the event of an internal power supply fault, a redundant circuit limits the maximum output voltage. The output switches off and automatically tries to switch on again.
Protection class	IP 20	EN/IEC 60529
Ingress protection	> 5 mm	e.g., screws, small parts
Overtemperature protection	yes	Output shutdown with automatic restart.
Protection against input transients	MOV (metal oxide varistor)	
Input fuse	included	Cannot be replaced by the user

¹⁾ In the event of a protection event, audible noises may occur.

3.17 Safety features

Safety features		
Input/output isolation (double or reinforced isolation)	SELV	IEC/EN 60950-1
	PELV	IEC/EN 60204-1, EN 62477-1, IEC 62103, IEC 60364-4-41
Protection class	I	PE (protective conductor) connection required
Insulation resistance	> 5 MOhm	between input and output, measured with 500 Vdc
PE resistance	< 0.1 ohm	Resistance between the protective conductor connection and the housing near the DIN rail mounting bracket.
Leakage current	Typ. 0.35 mA / 0.64 mA	At 3x 400 Vac, 50 Hz, TN, TT / IT network
	Typ. 0.45 mA / 0.91 mA	At 3x 480 Vac, 60 Hz, TN, TT / IT network
	Max. 0.45 mA / 0.78 mA	At 3x 440 Vac, 50 Hz, TN, TT / IT network
	Max. 0.60 mA / 1.20 mA	At 3x 528 Vac, 60 Hz, TN, TT / IT network

3.18 Dielectric strength

The output voltage is earth-free and has no ohmic connection to earth. Type and factory tests are carried out by the manufacturer. Field tests can be performed in the field using suitable test equipment that ramps up the voltage with a slow ramp (2 s rising and 2 s falling). Before performing the test, connect all phase connections and all output poles. During the test set the cut-off current to the value in the table below.

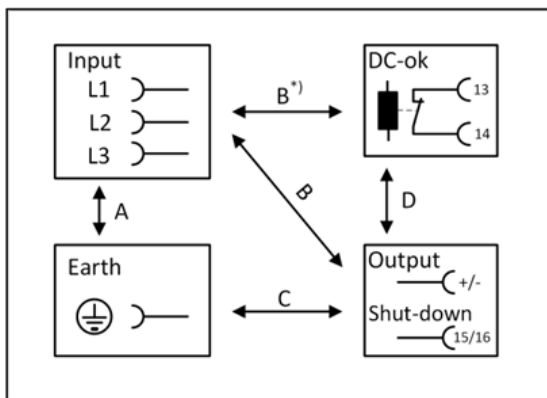

Fig. 19: Dielectric strength

¹⁾ When checking the input to DC-OK, make sure that the maximum voltage between DC-OK and the output is not exceeded (column D). We recommend connecting the DC-OK pins and the output pins when performing the test.

		A	B	C	D
Type test	60 s	2500 Vac	3000 Vac	500 Vac	500 Vac
Component test	5 s	2500 Vac	2500 Vac	500 Vac	500 Vac
Field test	5 s	2000 Vac	2000 Vac	500 Vac	500 Vac
Setting the cut-off current		> 10 mA	> 10 mA	> 40 mA	> 1 mA

To meet the PELV requirements according to EN 60204-1 section 6.4.1, we recommend that either the positive pole, the negative pole or any other part of the output circuit is connected to the protective earthing system. This helps to avoid situations where a load starts unexpectedly or cannot be disconnected if an unnoticed earth leakage occurs.

3.19 Declaration of conformity and approvals

	<p>EU declaration of conformity</p>
	<p>UK Declaration of Conformity Trade conformity assessment for England, Scotland and Wales The UKCA mark indicates conformity with the UK Statutory Instruments 2016 No. 1101 (LVD) 2016 No. 1091 (EMC) and 2012 No. 3032 (RoHS)</p>
	<p>Registration for the Eurasian Customs Union market (Russia, Kazakhstan and Belarus)</p>
	<p>UL Certificate, UL508 Applicable for US and Canada</p>

3.20 Dimensions and weight

Dimensions and weight	
Overall width	110 mm
Height	124 mm
Depth	127 mm The height of the DIN rails must be added to the depth of the device to calculate the total installation depth required
Weight	1500 g
DIN rail	Use 35 mm DIN rails according to EN 60715 or EN 50022 with a height of 7.5 or 15 mm.
Housing material	Housing: Aluminum alloy Cover: galvanized steel
Installation clearances	See chapter on Safety instructions and installation requirements [▶ 8]

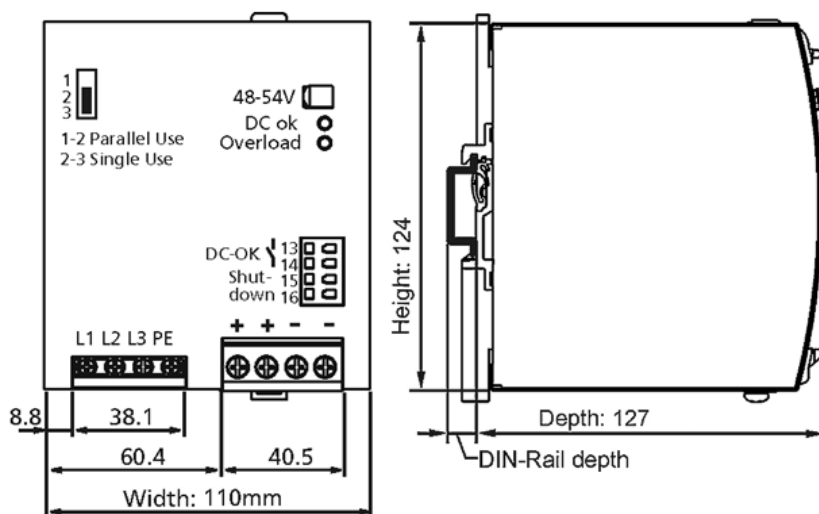

Fig. 20: Front/side view of PS3031-4820-0000, all specifications in mm

4 Application notes

4.1 Repeated pulse load

Typically a load current is not constant and varies with time. This power supply is designed to support loads with a higher short-term power demand (extra power). The short-term duration is hardware-controlled by an output power manager and is available repeatedly. If the extra power load lasts longer than the hardware controller allows, the output voltage drops. Extra power is available again after the extra power recovery time has elapsed (see [Output](#) [▶ 12] chapter).

To avoid this, the following conditions must be met:

- The power requirement of the pulse must be less than 150% of the rated output power.
- The duration of the pulse power must be shorter than the permitted extra power time. (see [Output power section](#) [▶ 12])
- The average (RMS) output current must be below the specified continuous output current. If the effective current is higher, the device responds with a thermal shutdown after a certain time. The maximum duty cycle curve (Fig. *Repeated pulse loads, definitions*) can be used to check whether the average output current is below the rated current.
- The duty cycle must be less than 0.75.

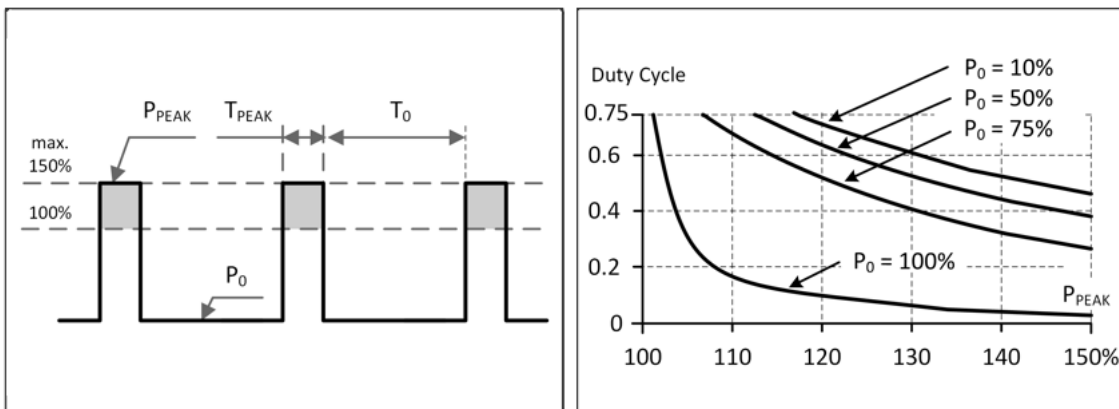

Fig. 21: Repeated pulse loads, definitions; Max. duty cycle curve

Key	
P_0	Base load (W)
P_{PEAK}	Pulse load (over 100%)
T_0	Duration between pulses (s)
T_{PEAK}	Pulse duration (s)

Calculation:

$$\text{Duty cycle} = T_{PEAK} / (T_{PEAK} + T_0)$$

$$T_0 = (T_{PEAK} - (\text{DutyCycle} \times T_{PEAK})) / \text{DutyCycle}$$

Example:

A load is operated continuously with 480 W (= 50% of the nominal output load).

From time to time a peak power of 1440 W (= 150% of the nominal output load) is required for 1 second.

- The question is: How often can this pulse be delivered without overloading the power supply?
 - Draw a vertical line at $P_{\text{PEAK}} = 150\%$ and a horizontal line where the vertical line crosses the curve $P_0 = 50\%$. Read the maximum duty cycle from the duty cycle axis (= 0.37)
 - Calculate the required pause length T_0 (base load):
 - Result: Required pause length = 1.7 s
 - Max. repetition rate = pulse + pause length = 2.7 s

$$T_0 = (T_{\text{PEAK}} - (\text{DutyCycle} \times T_{\text{PEAK}})) / \text{DutyCycle} = (1 \text{ s} - (0.37 \times 1 \text{ s})) / 0.37 = \mathbf{1.7 \text{ s}}$$

Further examples of pulse load tolerance

P_{PEAK}	P_0	T_{PEAK}	T_0
1440 W	960 W	1 s	>25 s
1440 W	0 W	1 s	>1.3 s
1200 W	480 W	1 s	> 0.75 s
1440 W	480 W	0.1 s	>0.16 s
1440 W	480 W	1 s	>1.6 s
1440 W	480 W	3 s	>4.9 s

4.2 Peak current capability

The device can deliver peak currents (for up to several milliseconds) that are higher than the specified short-term currents.

This helps when starting loads with high current intensity. Magnetic coils, contactors and pneumatic modules often have a stationary coil and a pick-up coil. The inrush current requirement of the pick-up coil is several times higher than the stationary current and usually exceeds the rated output current (including extra power). The situation is exactly the same when starting a capacitive load.

The peak current capability also ensures safe operation of downstream circuit breakers of load circuits. The load circuits are often individually fused with circuit breakers or fuses. In the event of a short circuit or overload in a circuit, the fuse or circuit breaker needs a certain amount of overcurrent to open in time. This prevents a voltage drop in adjacent circuits.

The additional current (peak current) is supplied by the power converter and the built-in large-size output capacitors of the power supply. The capacitors are discharged during such an event, which leads to a voltage drop at the output. The following two examples show typical voltage drops for ohmic loads:

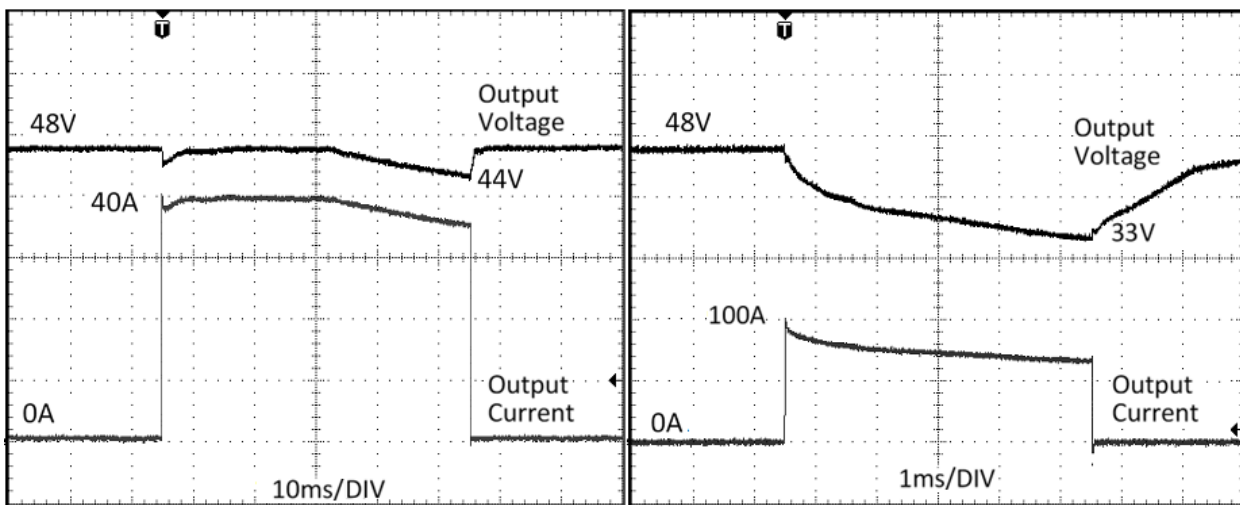

Fig. 22: 40 A peak current for 50 ms, typ. (2 x nominal current), 100 A peak current for 5 ms, typ. (5x nominal current)

● Control of DC-OK relay

i Please note: The DC-OK relay is activated if the voltage drops by more than 10% for more than 1 ms.

Peak current voltage drops	
Typically from 48 V to 44 V	At 40 A for 50 ms, ohmic load
Typically from 48 V to 38 V	At 100 A for 2 ms, ohmic load
Typically from 48 V to 33 V	At 100 A for 5 ms, ohmic load

4.3 External input protection

The device is tested and approved for circuits up to 30 A (UL) and 32 A (IEC). External protection is only required if the supply line has a protection that is higher than this. Also check the local regulations and requirements. Local regulations may apply in some countries.

If an external fuse is required or used, minimum requirements must be taken into account to avoid false tripping of the circuit breaker.

- A circuit breaker with a minimum value of 6 A with B or C characteristic should be used.

4.4 Operation on two phases of a 3-phase system

No external protective devices are required to protect against phase failure.

This power supply can also be operated continuously on two strings of a 3-phase system. However, it is not recommended for this performance class, since the feeding 3-phase network can become unbalanced.

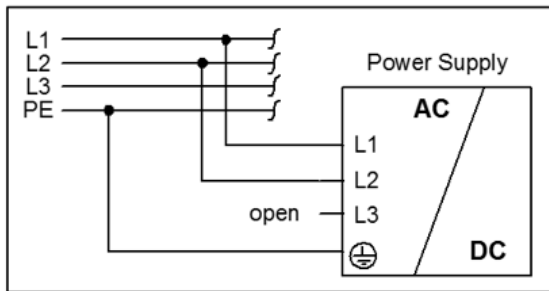

Fig. 23: Operation on two phases

- When operating on only two strings of a three-phase system, the output power must be reduced according to the curves below. Exceedance of these limit values over extended periods leads to thermal shutdown of the system.
- Operation below 340 Vac with an output current of more than 15 A can also cause a thermal shutdown.
- When switching on, there may be some start-up attempts until the output power is fully available.
- EMI behavior, hold-up time, losses and output ripple are different from three-phase operation. Therefore check the suitability for your individual application.
- The screw of the unused terminal must be firmly tightened.
- This kind of operation is not covered by the UL approval. Additional testing may be required if the complete system has to be approved according to UL 508 or UL 60950-1.

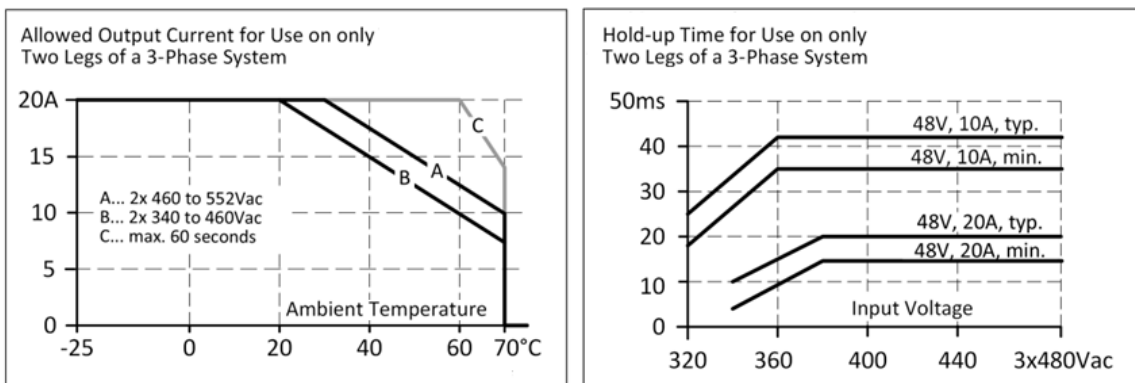

Fig. 24: When using only two phases: Permissible output current; hold-up time

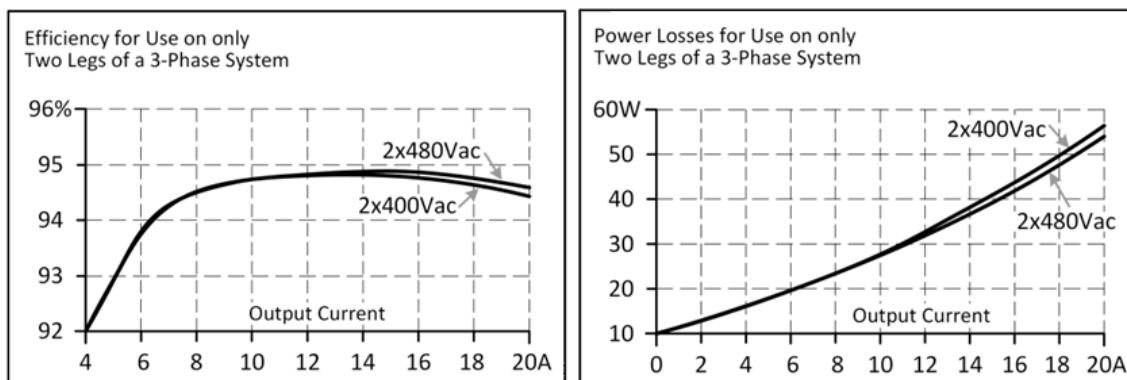

Fig. 25: Efficiency over output current at 48 V; losses over output current at 48 V

4.5 Output circuit breakers

Standard circuit breakers (or UL1077 circuit breakers) are generally used for AC supply systems and can also be used for DC branches.

Circuit breakers are used to protect cables and circuits. If the current value and the characteristics of the circuit breaker are matched to the cable thickness used, the wiring is considered thermally safe, regardless of whether the circuit breaker opens or not.

To avoid voltage drops and situations with undervoltage in adjacent 48 V branches fed from the same source, a fast (magnetic) trip of the circuit breaker is desirable. Fast switch-off within 10 ms is required, which approximately corresponds to the hold-up time of PLCs. This requires power supplies with high reserve current and large output capacitors. In addition, the impedance of the faulty branch must be sufficiently small for the current to actually flow. The following table contains typical test results that show which circuit breakers with B and C characteristics trip magnetically, depending on the wire cross-section and the wire length.

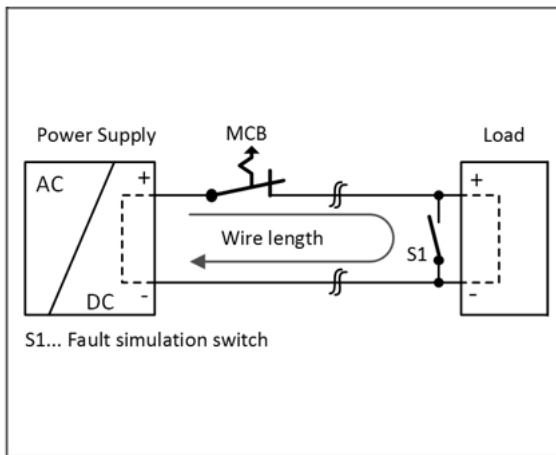

Fig. 26: Test circuit

Maximum wire length^{*)} for fast (magnetic) tripping:

	0.75 mm ²	1.0 mm ²	1.5 mm ²	2.5 mm ²
C-2A	74 m	89 m	146 m	190 m
C-3A	57 m	79 m	128 m	163 m
C-4A	43 m	52 m	73 m	116 m
C-6A	19 m	25 m	27 m	57 m
C-8A	8 m	12 m	17 m	25 m
C-10A	6 m	9 m	13 m	19 m
C-13A	3 m	5 m	7 m	10 m

	0.75 mm ²	1.0 mm ²	1.5 mm ²	2.5 mm ²
B-6A	38 m	52 m	76 m	113 m
B-10A	18 m	26 m	38 m	55 m
B-13A	12 m	19 m	29 m	42 m
B-16A	6 m	8 m	12 m	20 m
B-20A	1 m	2 m	4 m	5 m

^{*)} Don't forget to double the distance to the load (or the cable length) when calculating the total cable length (plus and minus cable).

4.6 Charging batteries

The power supply is not recommended for charging lead-acid batteries or maintenance-free batteries (SLA or VRLA batteries).

The PS3031-4820-0000 power supply cannot provide the recommended end-of-charge voltage of 55.0 V (at 20°C) for four 12 V lead-acid batteries in series.

4.7 Series connection

Power supplies of the same type can be connected in series to increase the output voltages. As many devices can be connected in series as necessary, as long as the sum of the output voltages does not exceed 150 Vdc. Voltages with a potential higher than 60 Vdc are no longer regarded as safety extra-low voltage and can be dangerous. Such voltages must be protected with a contact hazard protection.

- Grounding of the output is required if the sum of the output voltages is more than 60 Vdc.
- Avoid application of return voltage (e.g., from a braking motor or battery) to the output terminals.

Restrictions:

- Maintain an installation distance of 15 mm (left/right) between two power supplies.
- Do not install the power supplies above each other.
- Power supplies connected in series should only be used in the standard installation position (terminals on the underside of the device).
- Note that leakage current, electromagnetic interference, input inrush current, and harmonics increase when using multiple power supplies.

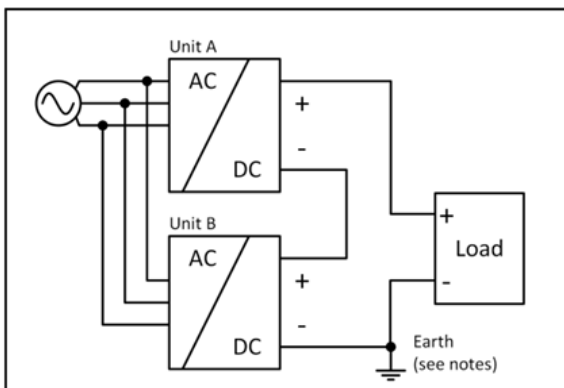

Fig. 27: Series connection

4.8 Parallel use to increase power

Power supplies of the same type from the PS3xxx series can be connected in parallel to increase the output power.

- The output voltage must be set to the same value (± 100 mV) in "Single Use" mode and with the same load conditions on all devices, or the units can be left with the factory settings.
- After the settings have been made, the jumper on the front of the device must be changed from "Single Use" mode to "Parallel Use" mode in order to achieve load splitting.
 - In "Parallel Use" mode the output voltage is regulated such that the voltage at no load is approx. 4% higher than at nominal load. See also [Output \[► 12\]](#) chapter.
 - If no jumper is plugged in, the device is in "Single Use" mode. The factory setting is also the "Single Use" mode.
- If more than three devices are connected in parallel, a fuse or circuit breaker with a rated current of 30 A or 32 A is required at each output. Alternatively a diode can be used.

Restrictions:

- Maintain an installation distance of 15 mm (left/right) between two power supplies.
- Do not install the power supplies above each other.
- In "Parallel Use" mode power supplies should only be used in the standard installation position (terminals on the underside of the device), not in other installation positions or under other conditions that require a reduction in the output current (e.g., installation altitude, operation at temperatures about $+60^{\circ}\text{C}$, ...).
- Note that leakage current, electromagnetic interference, input inrush current, and harmonics increase when using multiple power supplies.

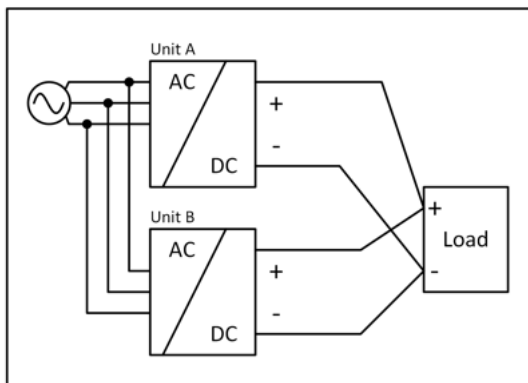

Fig. 28: Parallel connection

4.9 Parallel use for redundancy

Recommendations for the construction of redundant power supply systems:

- Power supplies that contain a DC-OK signal contact are best suited for the construction of redundant power supply systems.
 - Use this DC-OK signal contact to monitor the individual power supplies.
 - For the power supplies with EtherCAT (e.g. PS2001-2420-1001) the DC-OK bit can be used for monitoring.
- Use separate grids for each power supply whenever possible.
- It is recommended to set the output voltages of all devices to the same value (± 100 mV) or to leave them at the factory setting.

4.9.1 1+1 Redundancy

It is possible to connect power supplies in parallel for redundancy operation in order to achieve better system availability. Redundant systems provide a certain amount of additional power to operate the load when a power supply unit fails. The simplest method is to connect two power supplies in parallel. This is called 1+1 redundancy. If one power supply fails, the other can automatically supply the load current without interruption.

The 1+1 redundancy allows ambient temperatures up to +70 °C.

i Notes on parallel use for 1+1 redundancy

- Be sure to use a redundancy module in order to decouple devices from one another. This prevents the defective device from becoming a load for the other device and the output voltage no longer being maintainable.
- Note that leakage current, EMI, input inrush current and harmonics increase when using multiple devices.

Wiring example:

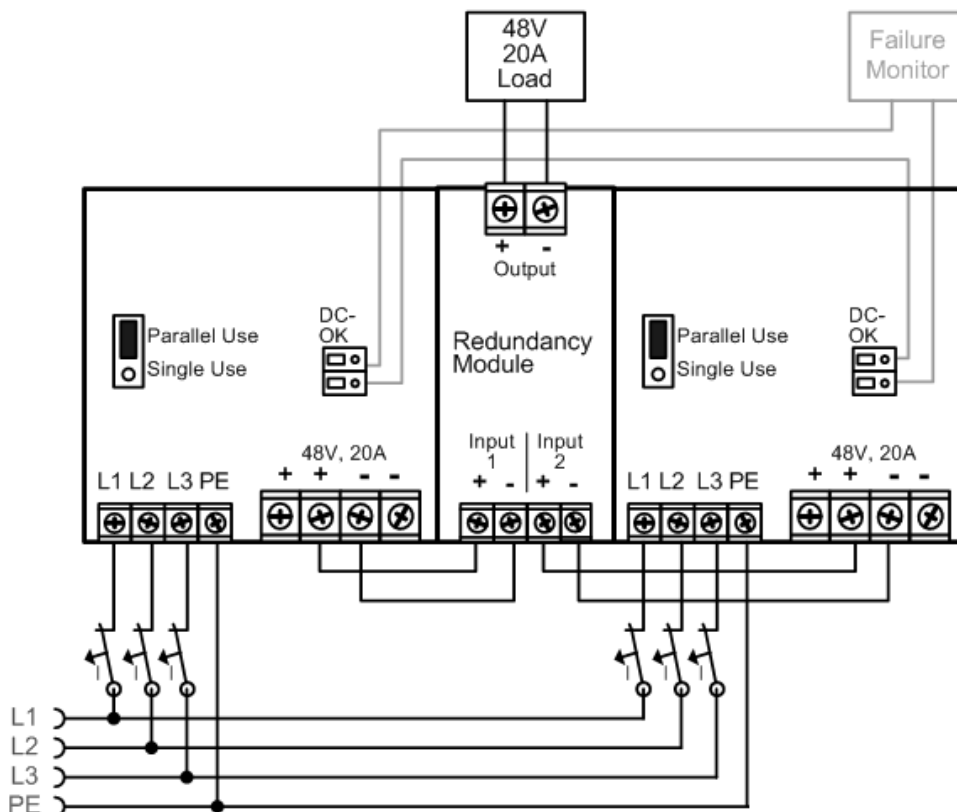

Fig. 29: Wiring for 1+1 redundancy with a PS9421-4840-0000 redundancy module

4.9.2 N+1 Redundancy

Notes on parallel use for N + 1 redundancy

- Note that leakage current, EMI, input inrush current and harmonics increase when using multiple devices.
- The ambient temperature may not exceed +60 °C for N + 1 redundancy systems.

Redundancy systems for higher power requirements are usually set up using the N + 1 method. For example, four devices with a nominal current of 10 A are connected in parallel for a 30 A redundancy system.

- Keep a mounting distance of 15 mm (left/right) between two power supplies.
- Do not install the power supplies above each other.
- Do not use power supplies connected in parallel in an installation position that deviates from the standard installation position (connection terminals on the underside of the device) or in a different state requiring a reduction in the output current.

Wiring example:

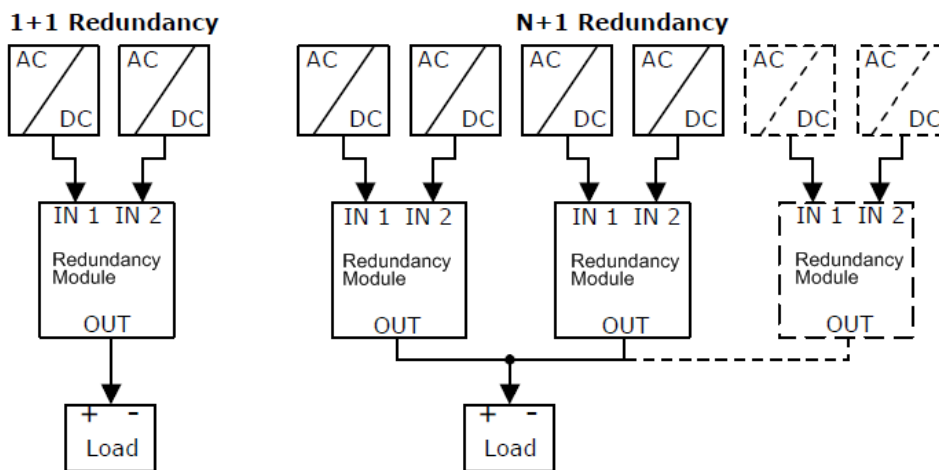

Fig. 30: Wiring for 1 + 1 redundancy and N + 1 redundancy

4.10 Inductive and capacitive loads

The device is designed to supply all load types, including capacitive and inductive loads.

4.11 Back-feeding loads

Loads such as braking motors or inductors can feed back voltage to the power supply. This feature is also known as back EMF. (electromagnetic force).

This power supply is stable and will not malfunction if a load is feeding back voltage to the power supply. It is irrelevant whether the power supply is switched on or off.

The maximum permissible feed-back voltage is 63 Vdc. The absorbing energy can be calculated according to the large built-in output capacitor indicated in the output data, see [Output \[► 12\]](#) chapter.

4.12 Use in a tightly sealed enclosure

When the power supply is installed in a tightly sealed enclosure, the temperature inside the housing is higher than outside. In this case, the temperature inside the housing is considered the ambient temperature for the power supply.

In the following test arrangement, the device is placed at the center of the housing, and there are no other heat-generating objects in the housing. The load is placed outside the housing.

The temperature sensor inside the housing is placed at the center of the right side of the power supply at a distance of 2 cm.

The following measurement results can be used as a reference to estimate the temperature rise within the housing.

Housing size:
254x180x165 mm Rittal housing, protection class IP66 PK 9522 100, plastic

Input voltage:
230 Vac

Load:
48 V, 16 A; (=80%)

Temperature inside the housing:
51.0°C

Temperature outside the housing:
21.8°C

Temperature increase:
29.2 K

4.13 Installation positions

Installation positions other than the input connections at the bottom and the output at the top require a reduction of the continuous output power or a limitation of the maximum permissible ambient temperature.

The extent of the reduction influences the lifetime expectancy of the power supply. Therefore, two different derating curves for continuous operation are provided below:

Curve A1: Recommended output current.

Curve A2: Max. permissible output current (results in about half the lifetime expectancy of A1).

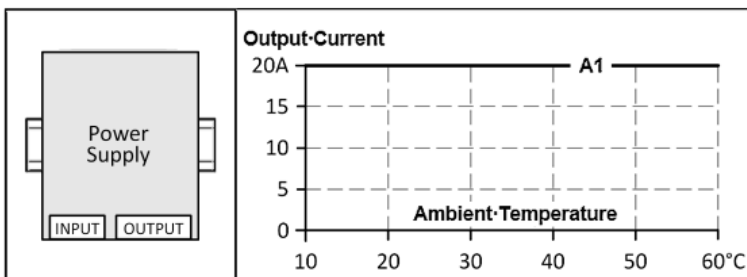

Fig. 31: Installation position A (standard installation position)

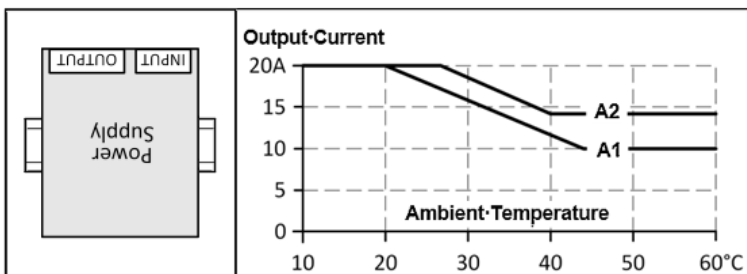

Fig. 32: Installation position B (upside down)

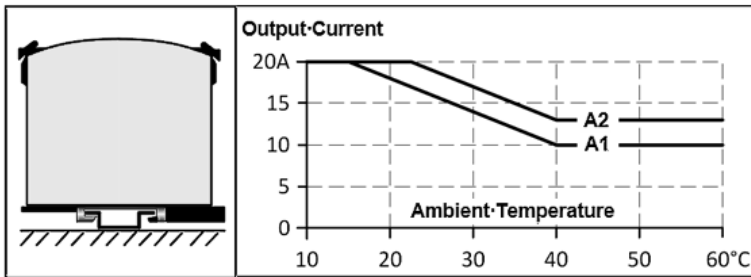

Fig. 33: Installation position C (table mounting)

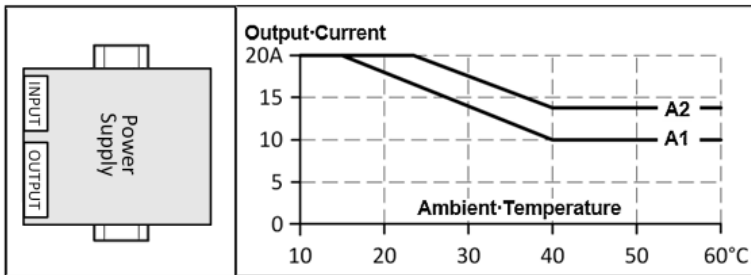

Fig. 34: Installation position D (horizontal clockwise)

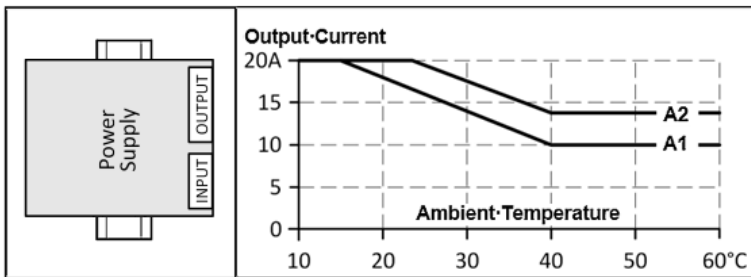

Fig. 35: Installation position E (horizontal counterclockwise)

5 Disposal



Products marked with a crossed-out wheeled bin shall not be discarded with the normal waste stream. The device is considered as waste electrical and electronic equipment. The national regulations for the disposal of waste electrical and electronic equipment must be observed.

6 Appendix

6.1 Accessories

6.1.1 Redundancy and buffer modules

Power supply	Accessories	
	Redundancy module	Buffer module
PS3031-4820-0000	PS9421-4840-0000	PS9031-4820-0001

PS9421-4840-0000– Redundancy Module



The PS9421-4840-0000 is a redundancy module that can be used for the construction of 1+1 and N+1 redundancy systems.

It has two input channels, to which power supplies with output currents of up to 20 A can be connected, and one output that can carry nominal currents of up to 40 A.

The redundancy module uses MOSFET technology instead of diodes for decoupling the two input channels. This reduces the heat development and the voltage drop between input and output. Due to the low power loss, the device is very narrow and requires a width of just 46 mm on the DIN rail.

Large connection terminals enable secure and fast installation.

The redundancy module requires no additional auxiliary voltage.

Due to the international approvals package, the device is suitable for virtually every application.

Observe the connection instructions in the chapter "[Parallel use for redundancy](#) [[▶ 39](#)]"

PS9031-4820-0001– Buffer Module



The PS9031-4820-0001 buffer module is an additional device for 48 V DC power supply units. It supplies power to bridge typical mains power failures or extends the hold-up time after switching off the AC voltage.

If the power supply unit supplies sufficient voltage, the buffer module stores energy in the integrated electrolytic capacitors. In the event of a failure of the mains voltage, the stored energy is supplied to the DC bus in a controlled process.

The buffer module can be connected at any point in parallel with the load circuit and does not require any control wiring.

A buffer module can provide 20 A of additional power and can be added in parallel to increase the output current or hold-up time.

6.1.2 Mounting accessories

Power supply	Accessories	
	Wall mounting	Side mounting
PS3031-4820-0000	ZS5301-0002	

ZS5301-0002 – Bracket for wall mounting

This bracket is used to mount the devices to a wall or panel without using a DIN rail.

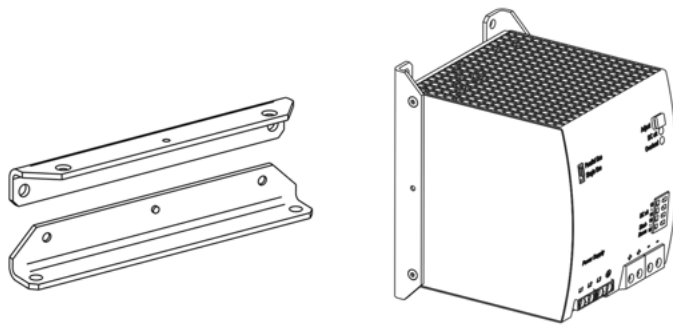

Fig. 36: ZS5301-0002, isometric view

6.2 Documentation issue status

Version	Comment
1.2	<ul style="list-style-type: none"> • Update chapter “Parallel use to increase power”
1.1	<ul style="list-style-type: none"> • Update chapter “Overview” • Update chapter “Declaration of conformity and approvals” • Chapters “Parallel use for redundancy” and “Disposal” added • Update chapter “Accessories” • Update structure
1.0	<ul style="list-style-type: none"> • First release • Corrections
0.1	<ul style="list-style-type: none"> • Preliminary documentation for PS3031-4820-0000

6.3 Support and Service

Beckhoff and their partners around the world offer comprehensive support and service, making available fast and competent assistance with all questions related to Beckhoff products and system solutions.

Beckhoff's branch offices and representatives

Please contact your Beckhoff branch office or representative for local support and service on Beckhoff products!

The addresses of Beckhoff's branch offices and representatives round the world can be found on her internet pages: www.beckhoff.com

You will also find further documentation for Beckhoff components there.

Support

The Beckhoff Support offers you comprehensive technical assistance, helping you not only with the application of individual Beckhoff products, but also with other, wide-ranging services:

- support
- design, programming and commissioning of complex automation systems
- and extensive training program for Beckhoff system components

Hotline: +49 5246 963 157
e-mail: support@beckhoff.com
web: www.beckhoff.com/support

Service

The Beckhoff Service Center supports you in all matters of after-sales service:

- on-site service
- repair service
- spare parts service
- hotline service

Hotline: +49 5246 963 460
e-mail: service@beckhoff.com
web: www.beckhoff.com/service

Headquarters Germany

Beckhoff Automation GmbH & Co. KG

Hülshorstweg 20
33415 Verl
Germany

Phone: +49 5246 963 0
e-mail: info@beckhoff.com
web: www.beckhoff.com

More Information:

www.beckhoff.com/ps3031-4820-0000

Beckhoff Automation GmbH & Co. KG
Hülshorstweg 20
33415 Verl
Germany
Phone: +49 5246 9630
info@beckhoff.com
www.beckhoff.com

