

Operating instructions | EN

# AL8000

Linear servo motors

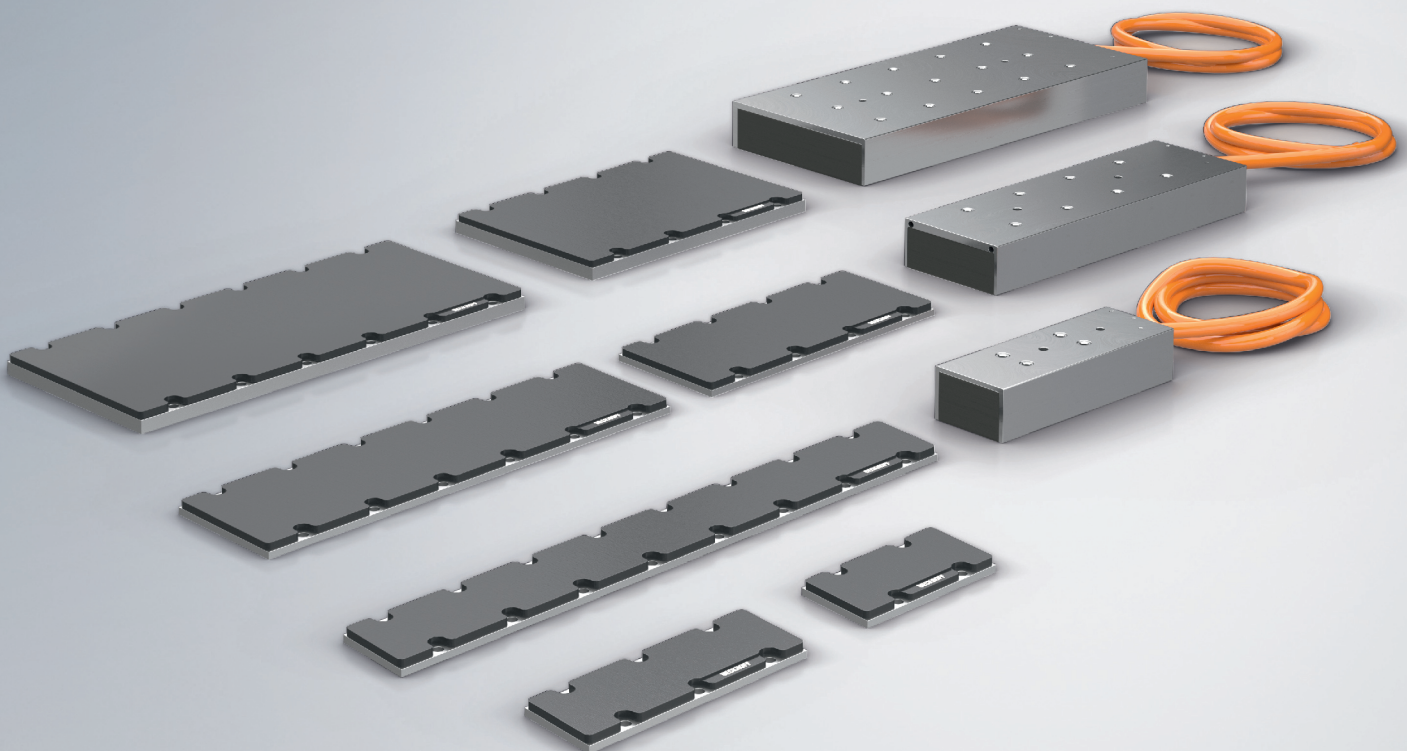



# Table of contents

<b>1 Documentation notes</b>	6
1.1 Disclaimer	6
1.1.1 Trademarks	6
1.1.2 Patents	6
1.1.3 Limitation of liability	7
1.1.4 Copyright	7
1.2 Version numbers	8
1.3 Scope of the documentation	8
1.4 Staff qualification	9
1.5 Safety and instruction	11
1.6 Explanation of symbols	11
1.7 Beckhoff Services	13
1.7.1 Support services	13
1.7.2 Training offerings	13
1.7.3 Service offerings	13
1.7.4 Headquarters Germany	14
1.7.5 Downloadfinder	14
<b>2 For your safety</b>	15
2.1 Safety pictograms	15
2.2 General safety instructions	16
2.2.1 Before operation	16
2.2.2 During operation	17
2.2.3 After operation	18
<b>3 Product overview</b>	19
3.1 Linear servomotor	20
3.1.1 Name plate	20
3.1.2 Type key	21
3.2 Magnetic plate	22
3.2.1 Name plate	22
3.2.2 Needle pattern marking	23
3.2.3 Type key	24
3.3 Product characteristics	25
3.4 Ordering options	26
3.4.1 Water cooling	26
3.4.2 Connection cables	26
3.5 Intended use	27
3.5.1 Improper use	27
<b>4 Technical data</b>	28
4.1 Definitions	28
4.1.1 Technical terms	28
4.2 Data for operation and environment	29
4.2.1 Power derating	30
4.3 AL802x	31
4.3.1 Dimensional drawings	32

4.3.2	AL802x alignment .....	35
4.4	AL852x magnetic plates .....	36
4.4.1	Dimensional drawings .....	36
4.5	AL804x .....	39
4.5.1	Dimensional drawings .....	41
4.5.2	AL804x alignment .....	47
4.6	AL854x magnetic plates .....	48
4.6.1	Dimensional drawings .....	48
4.7	AL806x-0 .....	50
4.7.1	Dimensional drawings .....	50
4.7.2	AL806x-0 alignment .....	54
4.8	AL806x-1 .....	55
4.8.1	Dimensional drawings .....	55
4.8.2	AL806x-1 alignment .....	60
4.9	AL856x magnetic plates .....	61
4.9.1	Dimensional drawings .....	61
<b>5</b>	<b>Scope of supply .....</b>	<b>63</b>
5.1	Packaging .....	63
5.1.1	Linear servomotor .....	63
5.1.2	Magnetic plate .....	64
<b>6</b>	<b>Transport and storage .....</b>	<b>65</b>
6.1	Conditions .....	65
6.2	Transport .....	66
6.2.1	Linear servomotors .....	66
6.2.2	Magnetic plates .....	67
6.3	Long-term storage .....	68
<b>7</b>	<b>Technical description .....</b>	<b>69</b>
7.1	Magnetic track length .....	69
7.1.1	Conventional calculation .....	69
7.1.2	Effective calculation .....	70
7.2	Air gap .....	72
7.2.1	Overall mounting height .....	72
7.2.2	Dependencies .....	73
7.3	Protection equipment .....	74
7.3.1	LPTC-600 sensor .....	74
<b>8</b>	<b>Coupling .....</b>	<b>75</b>
8.1	Structure .....	75
8.1.1	Gantry .....	75
8.1.2	Common magnetic track .....	76
8.2	Arrangement of coil parts .....	77
8.2.1	Cable arrangement .....	77
8.2.2	Cables in the same direction .....	79
8.2.3	Cables opposite .....	81
8.3	Electrical connection .....	83
8.3.1	Offset calculation .....	84



8.3.2	Phase lines .....	85
8.3.3	Power supply .....	86
8.3.4	Temperature sensor.....	86
<b>9</b>	<b>Mechanical installation .....</b>	<b>87</b>
9.1	Requirements .....	87
9.1.1	Evenness .....	87
9.2	Assembly.....	88
9.2.1	Coil part.....	89
9.2.2	Magnetic plates .....	91
9.2.3	Water cooling [+].....	94
9.3	Verification .....	99
9.3.1	Smooth operation.....	99
<b>10</b>	<b>Electrical installation .....</b>	<b>100</b>
10.1	Connection technology.....	100
10.1.1	Cables .....	100
10.2	Connector assignment .....	101
10.2.1	iTec® plug.....	101
10.2.2	M23 Speedtec® plug .....	101
10.2.3	M40 Speedtec® plug .....	102
<b>11</b>	<b>Commissioning .....</b>	<b>103</b>
11.1	Before commissioning.....	103
11.2	During commissioning.....	103
11.3	Prerequisites during operation .....	104
11.4	After operation.....	104
<b>12</b>	<b>Maintenance and cleaning.....</b>	<b>105</b>
12.1	Cleaning agents .....	105
12.1.1	Not applicable .....	105
<b>13</b>	<b>Decommissioning .....</b>	<b>106</b>
13.1	Disassembly.....	106
13.2	Disposal .....	107
13.2.1	Returning to the vendor .....	107
<b>14</b>	<b>Guidelines and Standards .....</b>	<b>108</b>
14.1	Standards.....	108
14.2	Guidelines .....	108
14.3	Test centers .....	108
14.4	EU conformity.....	109
14.5	CCC conformity.....	110

## 1 Documentation notes

### 1.1 Disclaimer

Beckhoff products are subject to continuous further development. We reserve the right to revise the operating instructions at any time and without prior announcement. No claims for the modification of products that have already been supplied may be made on the basis of the data, diagrams and descriptions in these operating instructions.

#### 1.1.1 Trademarks

Beckhoff®, TwinCAT®, TwinCAT/BSD®, TC/BSD®, EtherCAT®, EtherCAT G®, EtherCAT G10®, EtherCAT P®, Safety over EtherCAT®, TwinSAFE®, XFC®, XTS® and XPlanar® are registered and licensed trademarks of Beckhoff Automation GmbH.

The use of other brand names or designations by third parties may lead to an infringement of the rights of the owners of the corresponding designations.

#### 1.1.2 Patents

The EtherCAT technology is protected by patent rights through the following registrations and patents with corresponding applications and registrations in various other countries:

- EP1590927
- EP1789857
- EP1456722
- EP2137893
- DE102015105702



EtherCAT® is a registered trademark and patented technology, licensed by Beckhoff Automation GmbH.

### 1.1.3 Limitation of liability

All components in this product as described in the operating instructions are delivered in a specific configuration of hardware and software, depending on the application regulations. Modifications and changes to the hardware or software configuration that go beyond the documented options are prohibited and nullify the liability of Beckhoff Automation GmbH & Co. KG.

**The following is excluded from the liability:**

- Failure to observe these operating instructions
- Improper use
- Use of untrained personnel
- Use of unauthorized spare parts

### 1.1.4 Copyright

© Beckhoff Automation GmbH & Co. KG, Germany

The copying, distribution and utilization of this document as well as the communication of its contents to others without express authorization is prohibited. Offenders will be held liable for the payment of damages.

We reserve all rights in the event of registration of patents, utility models and designs.

## 1.2 Version numbers



### Provision of revision levels

On request, you can obtain a list of revision levels for changes in the operating instructions.

- Send your request to: [motion-documentation@beckhoff.de](mailto:motion-documentation@beckhoff.de)

### Origin of the document

These operating instructions were originally written in German. All other languages are derived from the German original.

### Product features

Only the product properties specified in the current operating instructions are valid. Further information given on the product pages of the Beckhoff homepage, in emails or in other publications is not authoritative.

## 1.3 Scope of the documentation

Apart from these operating instructions, the following documents are part of the overall documentation:

AL8000	Definition
Short information: Motor	Accompanying document with general instructions for handling the motors. This is included with every product.

## 1.4 Staff qualification

These operating instructions are intended for trained control and automation specialists with knowledge of the applicable and required standards and directives.

Specialists must have knowledge of drive technology and electrical equipment as well as knowledge of safe working on electrical systems and machines. This includes knowledge of proper setup and preparation of the workplace as well as securing the working environment for other persons.

The operating instructions published at the respective time of each installation and commissioning is to be used. The products must be used in compliance with all safety requirements, including all applicable laws, regulations, provisions and standards.

### **Instructed person**

Instructed persons have a clearly defined task area and have been informed about the work to be carried out. Instructed persons are familiar with:

- the necessary protective measures and protective devices
- the intended use and risks that can arise from use other than for the intended purpose

### **Trained person**

Trained persons meet the requirements for instructed persons. Trained persons have additionally received training from the machine builder or vendor:

- machine-specific or
- plant-specific

### **Trained specialists**

Trained specialists have received specific technical training and have specific technical knowledge and experience. Trained specialists can:

- apply relevant standards and directives
- assess tasks that they have been assigned
- recognize possible hazards
- prepare and set up workplaces

## **Qualified electricians**

Qualified electricians have comprehensive technical knowledge gained from a course of study, an apprenticeship or technical training. They have an understanding of control technology and automation. They are familiar with relevant standards and directives. Qualified electricians can:

- independently recognize, avoid and eliminate sources of danger
- implement specifications from the accident prevention regulations
- assess the work environment
- independently optimize and carry out their work

## 1.5 Safety and instruction

Read the contents that refer to the activities you have to perform with the product. Always read the chapter For your safety in the operating instructions. Observe the warnings in the chapters so that you can handle and work with the product as intended and safely.

## 1.6 Explanation of symbols

Various symbols are used for a clear arrangement:

- ▶ The triangle indicates instructions that you should execute.
- The bullet point indicates an enumeration.
- [...] The square brackets indicate cross-references to other text passages in the document.
- [1] The number in the square brackets refers to the position in the adjacent figure.
- [+] The plus sign in square brackets indicates ordering options and accessories.

In order to make it easier for you to find text passages, pictograms and signal words are used in warning notices:

### **DANGER**

Failure to observe will result in serious or fatal injuries.

### **WARNING**

Failure to observe may result in serious or fatal injuries.

### **CAUTION**

Failure to observe may result in minor or moderate injuries.



## NOTICE

Notes are used for important information on the product. The possible consequences of failure to observe these include:

- Malfunctions of the product
- Damage to the product
- Damage to the environment



### Information

This sign indicates information, tips and notes for dealing with the product or the software.



### Examples

This symbol shows examples of how to use the product or software.



### QR-Codes

This symbol shows a QR code, via which you can watch videos or animations. Internet access is required in order to use it.

You can read the QR code, for example, with the camera of your smartphone or tablet. If your camera doesn't support this function you can download a free QR code reader app for your smartphone. Use the Appstore for Apple operating systems or the Google Play Store for Android operating systems.

*If you cannot read the QR code on paper, make sure that the lighting is adequate and reduce the distance between the reading device and the paper. In the case of documentation on a monitor screen, use the zoom function to enlarge the QR code and reduce the distance.*

## 1.7 Beckhoff Services

Beckhoff and the worldwide partner companies offer comprehensive support and service.

### 1.7.1 Support services

Beckhoff Support offers technical advice on the use of individual Beckhoff products and system planning. Our support engineers offer you competent assistance, for comprehension questions as well as for commissioning.

 +49 5246 963-157

 [support@beckhoff.com](mailto:support@beckhoff.com)

 [www.beckhoff.com/en-en/support/our-support-services/](http://www.beckhoff.com/en-en/support/our-support-services/)

### 1.7.2 Training offerings

We offer worldwide training courses for our products and technologies, always concentrating on direct local contact with our customers. Please note that we offer both classroom and online training courses.

 +49 5246 963-5000

 [training@beckhoff.com](mailto:training@beckhoff.com)

 [www.beckhoff.com/en-en/support/training-offerings/](http://www.beckhoff.com/en-en/support/training-offerings/)

### 1.7.3 Service offerings

Our service experts support you worldwide in all areas of after-sales service.

 +49 5246 963-157

 [service@beckhoff.com](mailto:service@beckhoff.com)

 [www.beckhoff.com/en-en/support/our-service-offerings/](http://www.beckhoff.com/en-en/support/our-service-offerings/)

## 1.7.4 Headquarters Germany

Beckhoff Automation GmbH & Co. KG  
Hülshorstweg 20  
33415 Verl, Germany

 +49 5246 963-0

 [info@beckhoff.com](mailto:info@beckhoff.com)

 [www.beckhoff.com/en-en/](http://www.beckhoff.com/en-en/)

A detailed overview of our worldwide locations can be found online at Global presence.

 [www.beckhoff.com/en-en/company/global-presence/](http://www.beckhoff.com/en-en/company/global-presence/)

## 1.7.5 Downloadfinder

Our download finder contains all the files we offer for download: from our application reports to our technical documentation and configuration files.

 [www.beckhoff.com/documentations](http://www.beckhoff.com/documentations)

## 2 For your safety

Read this chapter containing general safety information. The chapters in these operating instructions also contain warning notices. Always observe the safety instructions for your own safety, the safety of other persons and the safety of the product.

When working with control and automation products, many dangers can result from careless or incorrect use. Work particularly thoroughly, not under time pressure and responsibly towards other people.

### 2.1 Safety pictograms

You will find safety symbols on Beckhoff products and packaging. The symbols may be glued, printed, or lasered on and may vary depending on the product. They serve to protect people and to prevent damage to the products. Safety symbols may not be removed and must be legible for the user.

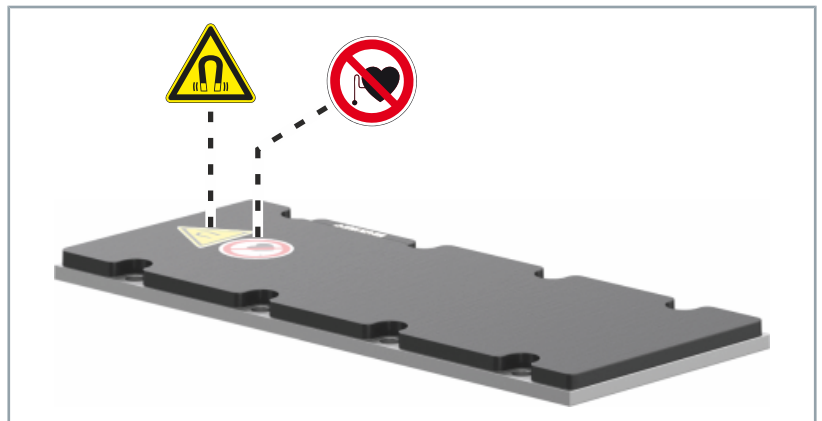

#### **Magnetic field warning**

Magnetic plates contain permanent magnets, which always generate a strong magnetic field and attract other magnetic objects, even in de-energized state. The high attractive forces cannot be controlled by hand. Avoid direct contact between the permanent magnets of the magnetic plates and ferromagnetic objects such as assembly trolleys, tools or machine beds.



#### **Danger from magnetic fields**

Magnetic fields on the magnetic plate can be dangerous for people with cardiac pacemakers or magnetically conductive implants and defibrillators, for example.

## 2.2 General safety instructions

This chapter provides you with instructions on safety when handling the product. This product is not capable of stand-alone operation and is therefore categorized as an incomplete machine. The product must be installed in a machine or plant by the machine manufacturer. Read the documentation prepared by the machine manufacturer.

### 2.2.1 Before operation

#### **Protective equipment**

Do not remove or bypass any protective devices. Check all protective devices before operation. Make sure that all emergency switches are present at all times and can be reached by you and other people. People could be seriously or fatally injured by unprotected machine parts.

#### **Danger from magnetic fields**

Magnetic fields on individual components of the AL8000 linear servomotors pose a risk to:

- persons with cardiac pacemakers or implanted or external defibrillators
- persons with magnetically conducting implants
- magnetic data storage devices, chip cards with magnetic strips and other electronic devices

Maintain a safety distance to all magnetic parts and prevent direct contact between magnetic parts and parts that are sensitive to interference.

Observe the requirements of BGV B 11 for electromagnetic fields (Germany) and applicable national regulations in other countries.

#### **Danger due to magnetic attraction**

The magnetic plates contain permanent magnets and attract other ferromagnetic objects. The high attractive forces cannot be controlled by hand.

Ensure a safety distance of at least 25 cm from the magnetic plate to other ferromagnetic parts, e.g. iron.

Observe the requirements of BGV B 11 for electromagnetic fields (Germany) and applicable national regulations in other countries.

**Shut down and secure the machine or plant**

Shut down the machine or plant. Secure the machine or plant against being inadvertently started up.

**Correctly ground electrical components or modules**

Avoid electric shocks due to improper grounding of electrical components or modules. Ground all conductive components according to the specifications in the chapters "Electrical Installation" and "Mechanical Installation".

**Keep the immediate environment clean**

Keep your workplace and the surrounding area clean. Ensure safe working.

**Check safety pictograms**

Check whether the designated pictograms are on the product. Replace missing or illegible stickers.

**Observe tightening torques**

Mount and repeatedly check connections and components, complying with the prescribed tightening torques.

**Avoid spalling of the sealing compound due to hard knocks**

In case of improper use or due to hard knocks, the sealing compound can spall and the product can be damaged.

**Use the original packaging only**

Use the original packaging for dispatch, transportation, storage and packing.

## 2.2.2 During operation

**Do not work on live electrical parts**

Ensure that the protective conductor is connected properly. Measure the voltage on the DC link test contacts DC+ und DC-. Do not work on the linear motor until the voltage has dropped below 50 V DC. Never loosen electrical connections when live. Disconnect all components from the mains and secure them against being switched on again.

**Do not touch hot surfaces**

Check the cooling of the surfaces with a thermometer. Do not touch the components during and immediately after operation. Allow the components to cool sufficiently after switching off.

**Avoid overheating**

Activate and monitor the temperature contact of the motor. Provide for sufficient cooling. Switch off the motor immediately if the temperature is too high.

**Do not touch any moving or rotating components**

Do not touch any moving or rotating components. Fasten all parts or components on the machine or plant.

## 2.2.3 After operation

**De-energize and switch off components before working on them**

Check the functionality of all safety-relevant devices. Secure the working environment. Secure the machine or plant against being inadvertently started up. Observe the chapter: "Decommissioning".



### 3 Product overview

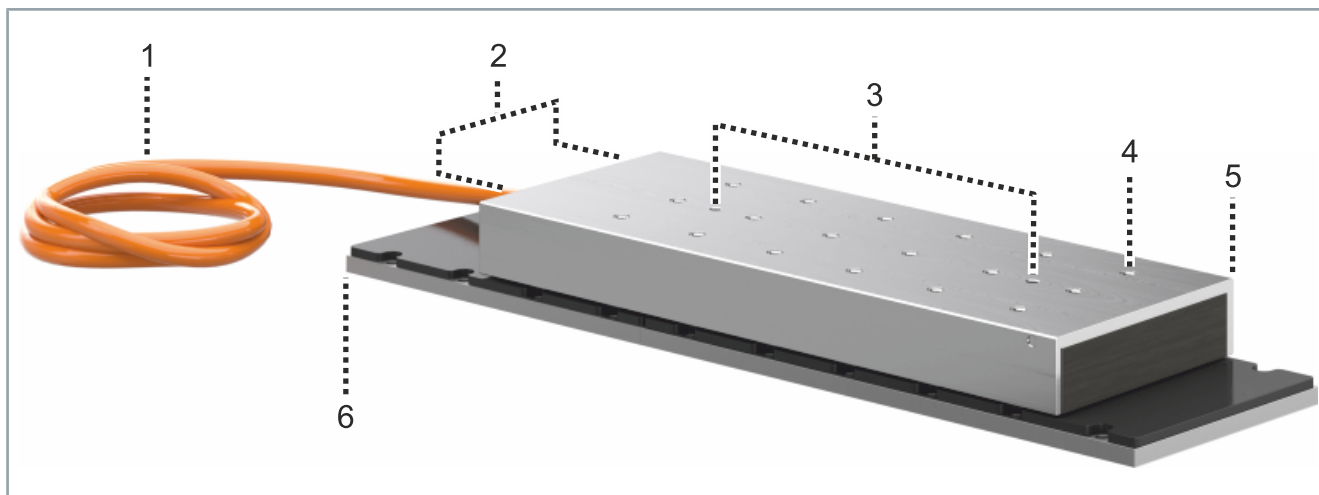

Number	Explanation
1	Cable: power and temperature sensor
2	Water cooling connection [ + ]
3	Holes for locating pins
4	Thread for mounting on the machine slide
5	Primary component: coil part of the linear servomotor
6	Secondary part: Magnetic plate

3.1 Linear servomotor

3.1.1 Name plate

**BECKHOFF** Automation GmbH & Co. KG  
 Huelshorstweg 20 D-33415 Verl Germany  
 Phone: + 49 52 46 9 63 - 0  
 Fax: + 49 52 46 9 63 - 198  
 www.beckhoff.com info@beckhoff.com

1..... **Type** : **AL 8042-0E01- 0000 Linear Servomotor**  
 2..... Article No. : 222605  
 3..... BTN No. : 00406595  
 4..... Fmax 460 N ..... Imax 7,2 Arms  
 5..... Fc 200 N ..... Ic 2,5 Arms  
 6..... Vmax 7 m/s ..... UN 400 Vrms  
 7..... IP64 / IC400 ..... ThCl B

18 17  
 16  
 15  
 14  
 13  
 12  
 8 9 10 11

Item number	Explanation
1	Article description
2	Order number
3	BTN = <b>B</b> eckhoff- <b>T</b> raceability- <b>N</b> umber
4	Peak force
5	Continuous force
6	Maximum velocity
7	Protection class
8	Peak current
9	Continuous current
10	Nominal voltage
11	Insulation class
12	cURus approval
13	WEEE compliance
14	Country of manufacture
15	UKCA marking
16	Data matrix code
17	CE conformity
18	EAC approval

## 3.1.2 Type key

AL8 t u v - w x y z - 0000	Explanation
AL8	Product area • Iron-core series 8 linear servomotors
t	Series • 0 = 400 V AC
u	Overall width • 2 = W2; 50 mm 4 = W4; 80 mm 6 = W6; 130 mm
v	Overall length • 1 = 3 2 = 6 3 = 9 4 = 12 5 = 15 6 = 18 8 = 24 A = 30 F = 45
w	Cooling • 0 = convection 1 = water cooling
x	Winding letter • A ... Z S = special winding
y	Feedback system • 0 = without feedback
z	Connection technology • 0 = cable tail without plug 1 = cable tail with plug
0000	Not used

## 3.2 Magnetic plate

### 3.2.1 Name plate

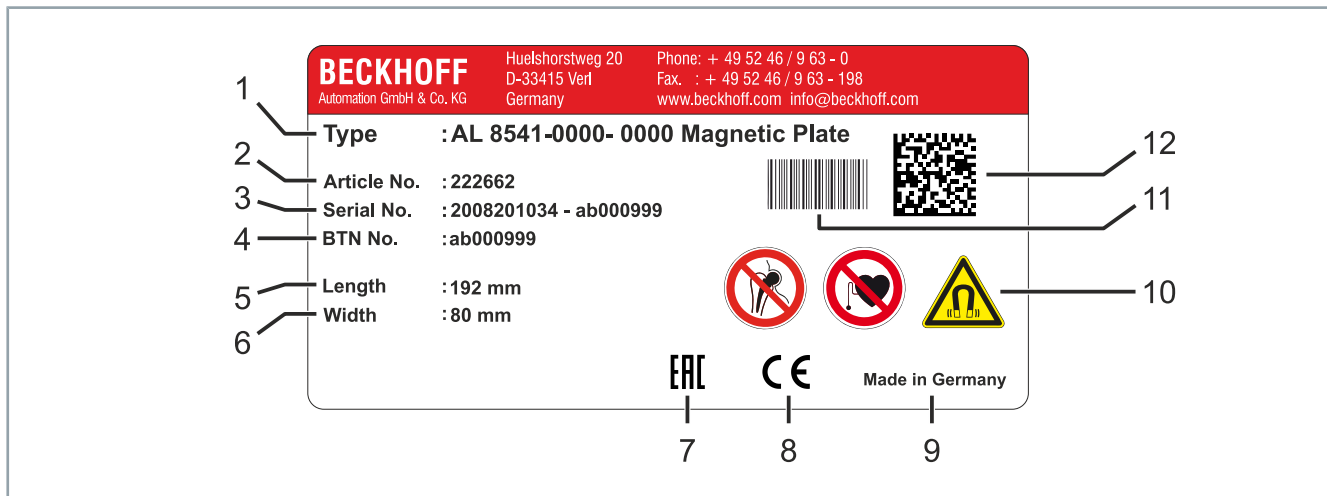

Number	Explanation
1	Article description
2	Order number
3	Serial number
4	Beckhoff traceability number
5	Length
6	Width
7	EAC approval
8	CE conformity
9	Country of manufacture
10	Safety pictograms
11	Barcode
12	Data matrix code

3.2.2 Needle pattern marking

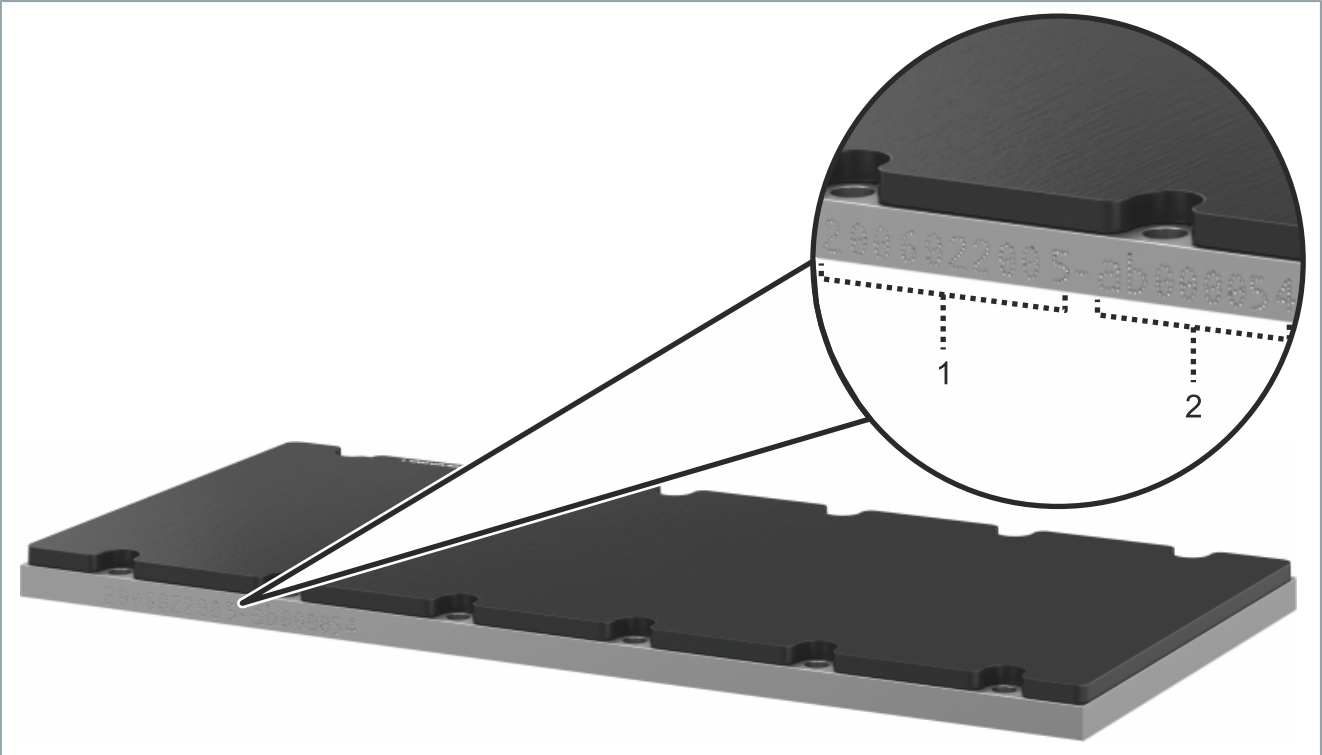

Number	Explanation
1	Serial number, 10 digits
2	Beckhoff BTN, 8 digits

## 3.2.3 Type key

<b>AL8 t u v - 0000 - 0000</b>	<b>Explanation</b>
AL8	Product line – Iron-core series 8 linear servomotors
t	Series – 5 = magnetic plate
u	Overall width – 2 = W2; 50 mm 4 = W4; 80 mm 6 = W6; 130 mm
v	Overall length – 1 = short 2 = medium 3 = long
0000 - 0000	Not used

### 3.3 Product characteristics

#### Dust-protected IP64 housing

The coil parts are suitable for a wide range of environmental conditions. The coil parts and magnetic plates are fully potted and IP64 protected, making the components dustproof and suitable for temporary immersion.

#### Neodymium permanent magnets

Neodymium permanent magnets are built into the magnetic plate. Neodymium is a hard magnetic material with strong magnetic fields that facilitate high forces.

#### Coupling to servo drives

The coil parts are available with pre-assembled cables and connectors. This significantly reduces the cabling effort and prevents wiring faults. They can be coupled to servo drives.

#### Electronic commutation in the servo drive

The commutation of the motor is done electronically. The three coils are supplied from a bridge circuit.

#### Thermal contacts

A thermal contact "LPTC-600", [Page 74] is installed to monitor and measure the winding temperature and to protect the motor against overheating. This can be read out by the user.

#### Temperature warning and switch-off

- Motor warning temperature at 80 °C
- Motor switch-off temperature at 100 °C

#### Uniform linear motor width

Within a width category, such as AL802x, the coil parts have identical width and can therefore be operated together on one magnetic track and combined as desired.



## 3.4 Ordering options

Ordering options are defined via the type key and must be ordered separately. It is not possible to fit one at a later date.

### 3.4.1 Water cooling

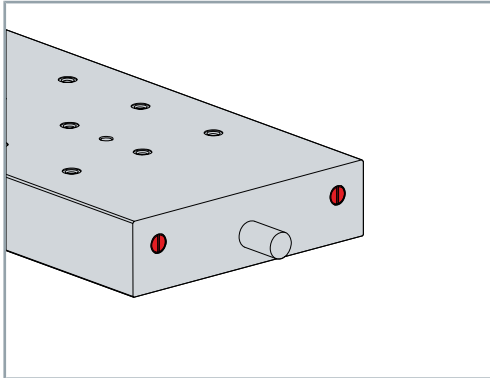

The coil parts of the AL8000 series are available with convection cooling or water cooling. The connection of a water cooling system enables a higher continuous force of the linear motor.

This ordering option is available for coil parts of the following series:

- AL804x
- AL806x

### 3.4.2 Connection cables

The coil parts can be ordered either with pre-assembled connection cables and plugs or with open wire end sleeves.

#### 3.4.2.1 Plug

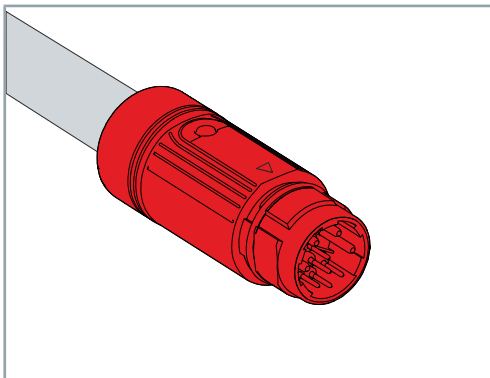

The following plug variants are used, depending on the cable diameter:

- iTec® plug
- M23-speedtec® plug
- M40-speedtec® plug

#### 3.4.2.1.1 Wire end sleeves

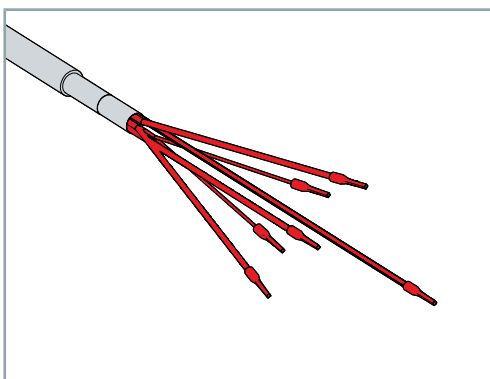

If you do not require a plug, you can order the connection cables with ferrules.

## 3.5 Intended use

The linear servomotors of the AL8000 series may only be operated for the intended activities defined in this documentation under the specified ambient conditions.

The components are installed in electrical systems or machines. Independent operation of the components is not permitted.

The thermal protection contact installed in the motor windings must be regularly evaluated and monitored.



### **Read the entire drive system documentation:**

- This translation of the original instructions
- Translation of the original instructions of the servo drive used
- Complete machine documentation provided by the machine manufacturer

### 3.5.1 Improper use

Any type of use that exceeds the permissible values from the technical data is regarded as inappropriate and is thus prohibited.

Beckhoff AL8000 linear servomotors are not suitable for use in the following situations:

- Potentially explosive atmospheres
- Areas with aggressive environments, for example aggressive gases or chemicals
- Areas with ionizing radiation and nuclear plants
- Aerospace industry
- Operation directly in the supply network without servo drive

## 4 Technical data

### 4.1 Definitions

All data valid for 40 °C ambient temperature and 60 K overtemperature of the winding. The data can have a tolerance of +/- 10 %.

#### 4.1.1 Technical terms

This chapter provides information on various technical terms and their meaning.

Peak force $F_{\max}$ [N]	Peak force at peak current $I_{\max}$ . The force that can be achieved depends on the peak output current of the servo drive used. The peak force results in significant heating of the motor and may be delivered permanently for a maximum of 5 seconds; S5 operation.
Peak current $I_{\max}$ [A]	RMS value of the peak current at peak force $F_{\max}$ .
Continuous force $F_c$ [N]	Available continuous force in S1 operation close to standstill at continuous current $I_c$ .
Continuous current $I_c$ [A]	RMS value of the continuous current at continuous force $F_c$ .
Maximum velocity $V_{\max}$ [m/s]	Maximum velocity of the linear motor.
Force constant $K_f$ [N/A]	Ratio of force to current while maintaining the design air gap.
Magnetic attractive force $F_a$ [N]	Attractive force between magnetic plate and coil part. Exists even when no current is flowing. Increases with the size of the coil part and depends on the size of the air gap. See Chapter "Air gap", [Page 72]. Increases by up to 10% when the peak current is reached
Continuous power dissipation $P_c$ [W]	Maximum power dissipation of the linear motor. Can be used for the calculation of the cooling systems.
Pole pair distance [mm]	Distance across a pole pair, north pole and south pole, of the magnetic plate.
Air gap [mm]	Distance between magnetic plate and coil part. Must be observed during assembly to achieve the specified values of the linear motor.

## 4.2 Data for operation and environment

### NOTICE

#### Operate linear motors only under the specified environmental conditions

Operate the linear motors only under the conditions for operation and the environment listed in this chapter. This ensures a long service life and proper operation.

*Short-term or long-term operation outside of the specifications listed here may reduce the service life of the coil parts.*

Beckhoff products are designed for operation under certain environmental conditions, which vary according to the product. The following specifications must be observed for operation and environment in order to achieve the optimum service life of the products.

Environmental requirements	
• Climate category - operation	3K3 according to EN 60721
• Ambient temperature during operation	+ 5 °C to + 40 °C
• Ambient temperature during transport	- 25 °C to + 70 °C, maximum fluctuation 20 K/hour
• Ambient temperature during storage	- 25 °C to + 70 °C, maximum fluctuation 20 K/hour
• Power derating	No power derating up to 1000 m installation altitude above sea level.
• Installation altitude	At installation heights higher than 1000 m above sea level and 40 °C: <ul style="list-style-type: none"> <li>• 6 % at 2000 m above sea level</li> <li>• 17 % at 3000 m above sea level</li> <li>• 30 % at 4000 m above sea level</li> <li>• 55 % at 5000 m above sea level</li> </ul>
• Permissible humidity during transport and storage	5 % to 95 % relative humidity, non-condensing
Specifications for intended use	
• Ventilation	Air-cooled or water-cooled
• Insulation material class	B
• Protection class	IP64
• Vibration resistance	50 g, 10...2000 Hz according to EN 60068-2-6
• Shock resistance	100 g, 6 ms according to EN 60068-2-27
• EMC requirements	conforms to EN 61800-3:2004 + A1:2012
• Approvals	CE, cURus, EAC, UKCA

## 4.2.1 Power derating

Derating may be necessary at high ambient temperature or when operating at a great height above sea level. Continuous forces are affected by the reduction.

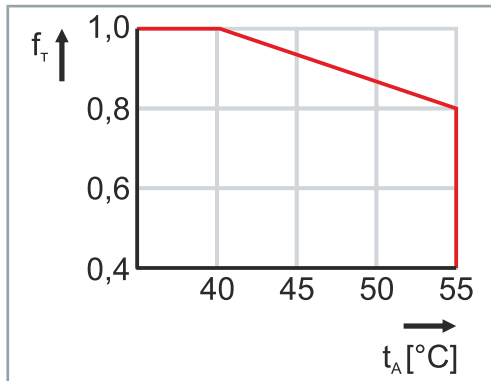

### Ambient temperature

$f_T$  = Temperature utilization factor

$t_A$  = Ambient temperature in  $^{\circ}\text{C}$

Calculation of the power data when exceeding the specified temperature limit  $> 40^{\circ}\text{C}$ :

$$F_{CA\_red} = F_C \times f_T$$

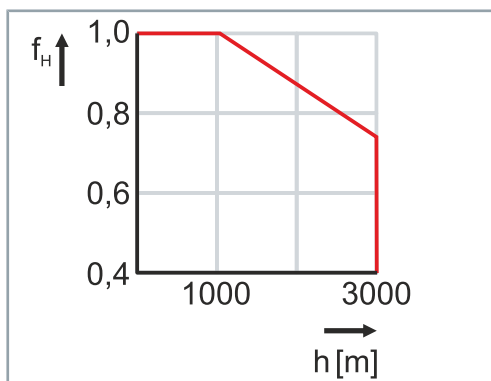

### Installation altitude

$f_H$  = Altitude utilization factor

$h$  = Altitude in meters

Calculation of the performance data if the installation altitude exceeds 1000 m:

$$F_{CA\_red} = F_C \times f_H$$

### Ambient temperature and installation altitude

Calculation of the power data when exceeding the specified limits:

Ambient temperature  $> 40^{\circ}\text{C}$  and installation altitude  $> 1000$  m above sea level:

$$F_{CA\_red} = F_C \times f_T \times f_H$$

## 4.3 AL802x

Performance data	AL80			
	21-0E	22-0E	24-0G	26-0G
• Peak force $F_{\max}$ [N]	120	240	480	720
• Peak current $I_{\max}$ [A]	7.3	7.3	12	12
• Continuous force $F_c$ [N]	60	120	240	360
• Continuous current $I_c$ [A]	3	3	4.8	4.8
• Maximum velocity $v_{\max}$ [m/s]	12	12	12	10
• Force constant $K_f$ [N/A]	20	40	50	75
• Magnetic attractive force $F_a$ [N]	360	520	850	1250
• Winding resistance ph-ph [ $\Omega$ ]	2.8	5.7	4.1	6.1
• Winding inductance ph-ph [mH]	13	26	20	30
• Counter EMF ph-ph [V/m/s]	11	23	29	43
• Continuous power loss $P_c$ [W]	57	114	202	303
• Motor constant [N <sup>2</sup> /W]	63	126	285	428
• Thermal resistance [K/W]	1.1	0.5	0.3	0.2
• Pole pair distance [mm]	24	24	24	24
<b>Weight</b>				
• Coil unit [kg]	0.6	0.9	1.6	2.3
• Magnetic plate [kg/m]	2.1			
<b>Sensors</b>				
• Air gap [mm]	0.5			
• Temperature sensor	LPTC-600; compatible with KTY 84-130			
<b>Cable and motor data</b>				
• Outer diameter [mm]	9			
• Wire cross-section	4 x 1.0 mm <sup>2</sup> + 2 x AWG26			
• Minimum static bending radius	4 x outer diameter			
• Cable length, assembled [m]	0.5			
• Cable length unassembled [m]	1			
• Connector	iTec®			
<b>Recommended servo drive assignment</b>				
• AX5000	AX5x03	AX5x03	AX5x06	AX5x06
• AX8000	AX8108/AX8206			
<i>The values are valid for a linear servomotor mounted on a metal surface that is equal to or larger than that of the motor, at a surface temperature of 20°C</i>				







## 4.3.1.3 AL8024

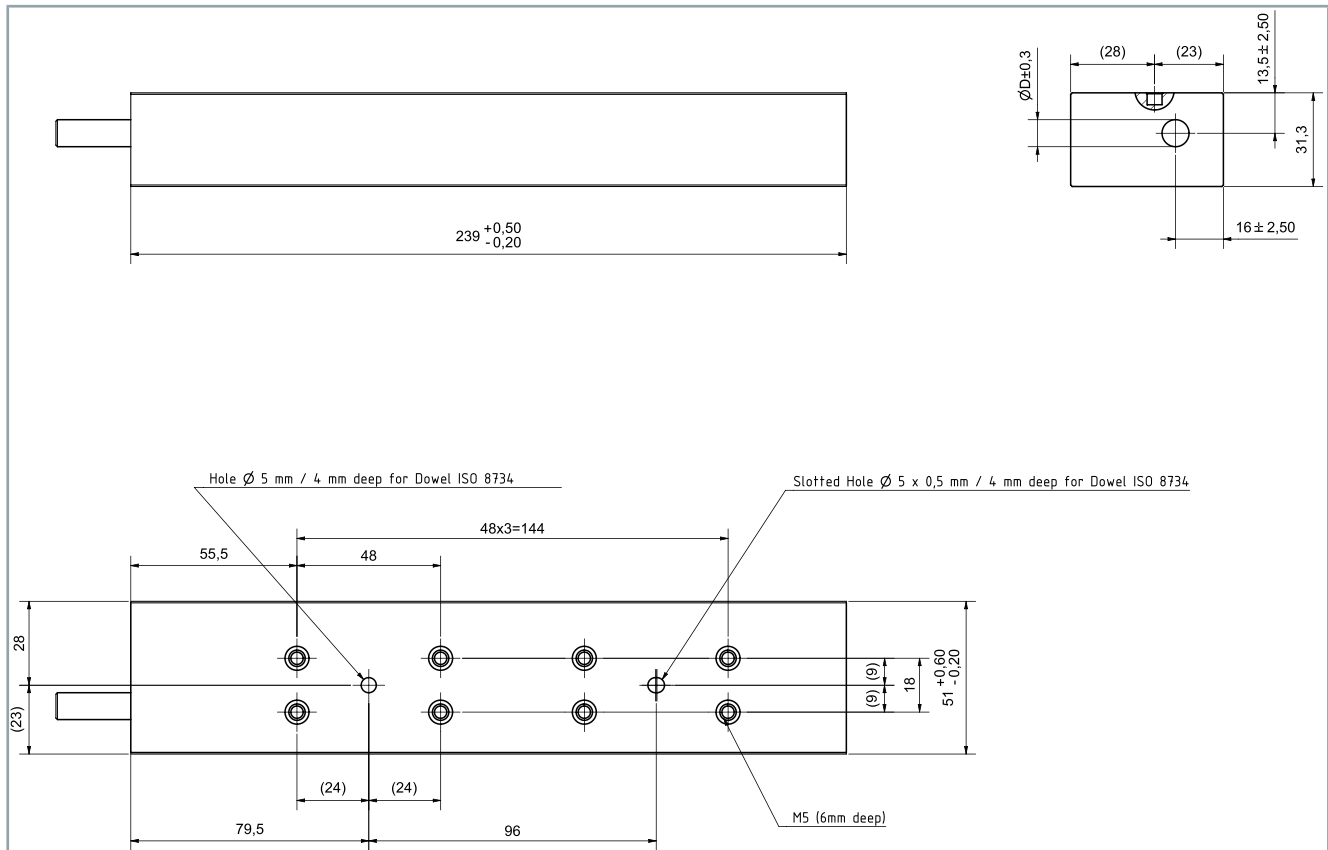

## 4.3.1.4 AL8026

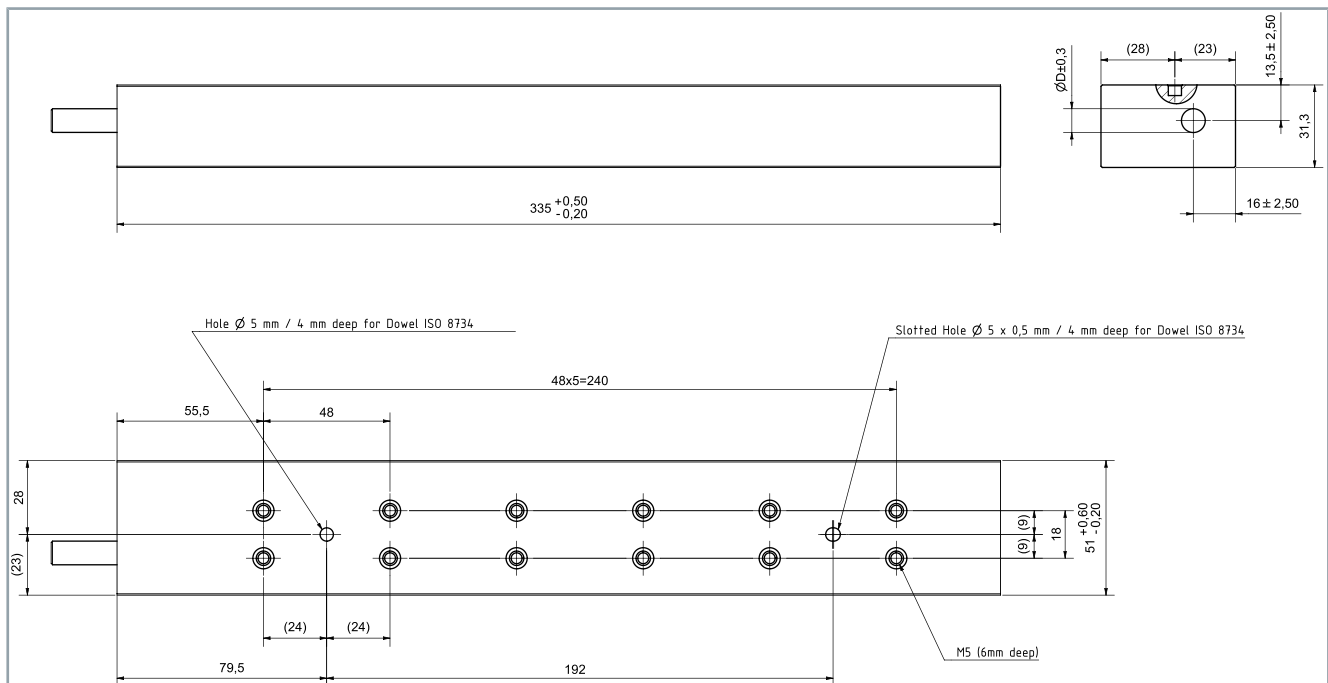

### 4.3.2 AL802x alignment



#### Alignment based on AL802x as an example

The figure shows the positioning of a coil part in relation to the magnetic track.

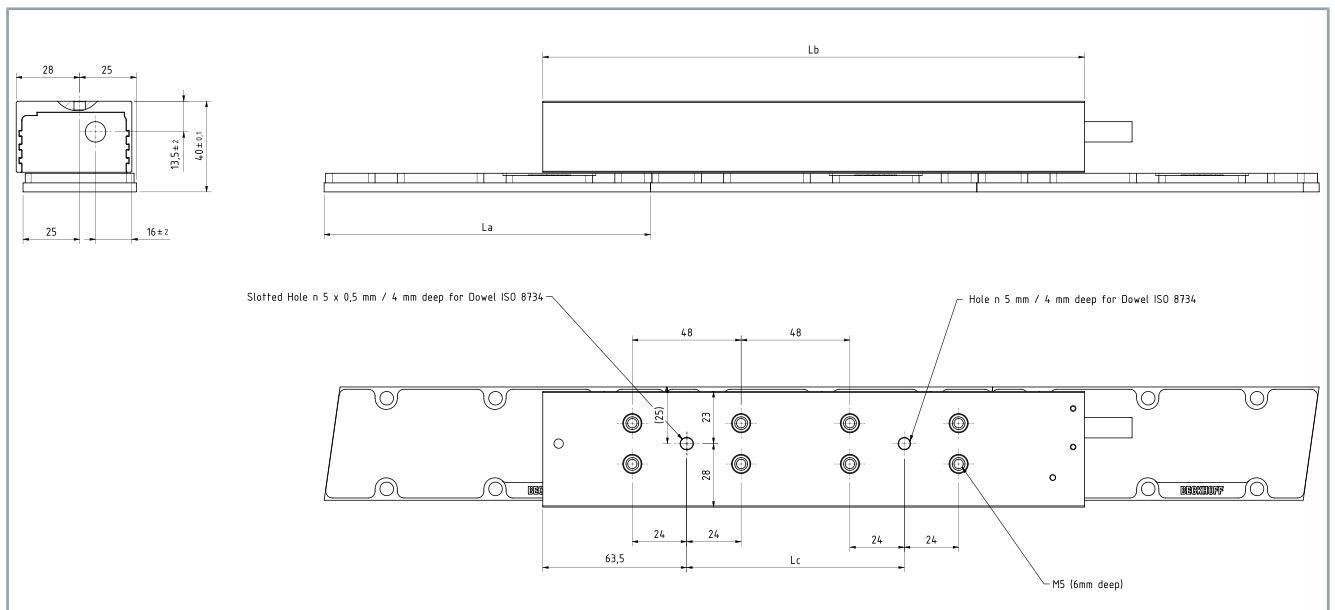

## 4.4 AL852x magnetic plates

### 4.4.1 Dimensional drawings

- All figures in millimeters

#### Hole:

- 6 mm diameter for screw M5 DIN7984, short head
- 5 mm diameter, 3.5 mm depth for locating pin with diameter 5 m6

#### Elongated hole:

- 5 mm x 0.5 mm diameter, 3.5 mm depth for locating pin with diameter 5 m6

#### 4.4.1.1 AL8521

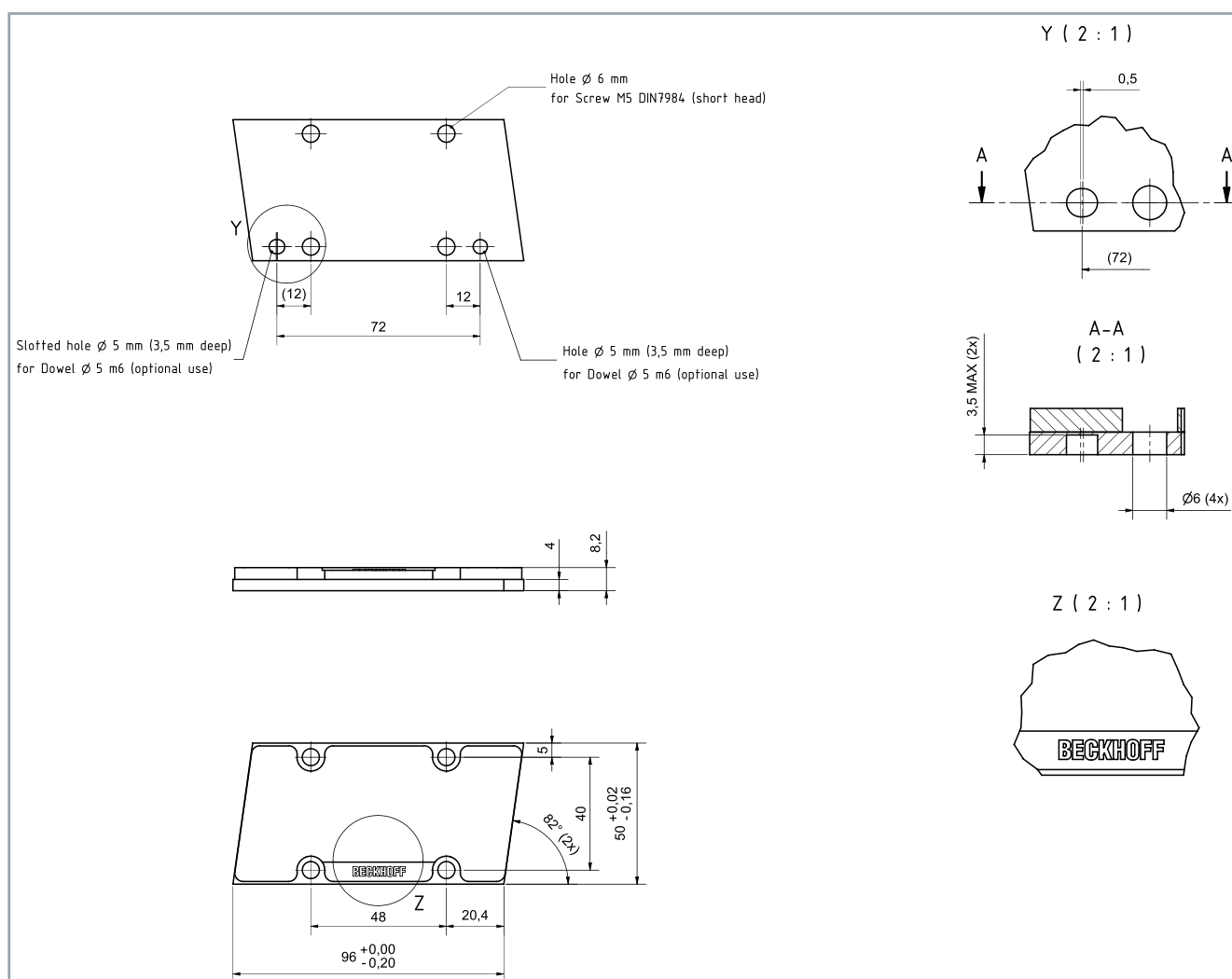

## 4.4.1.2 AL8522

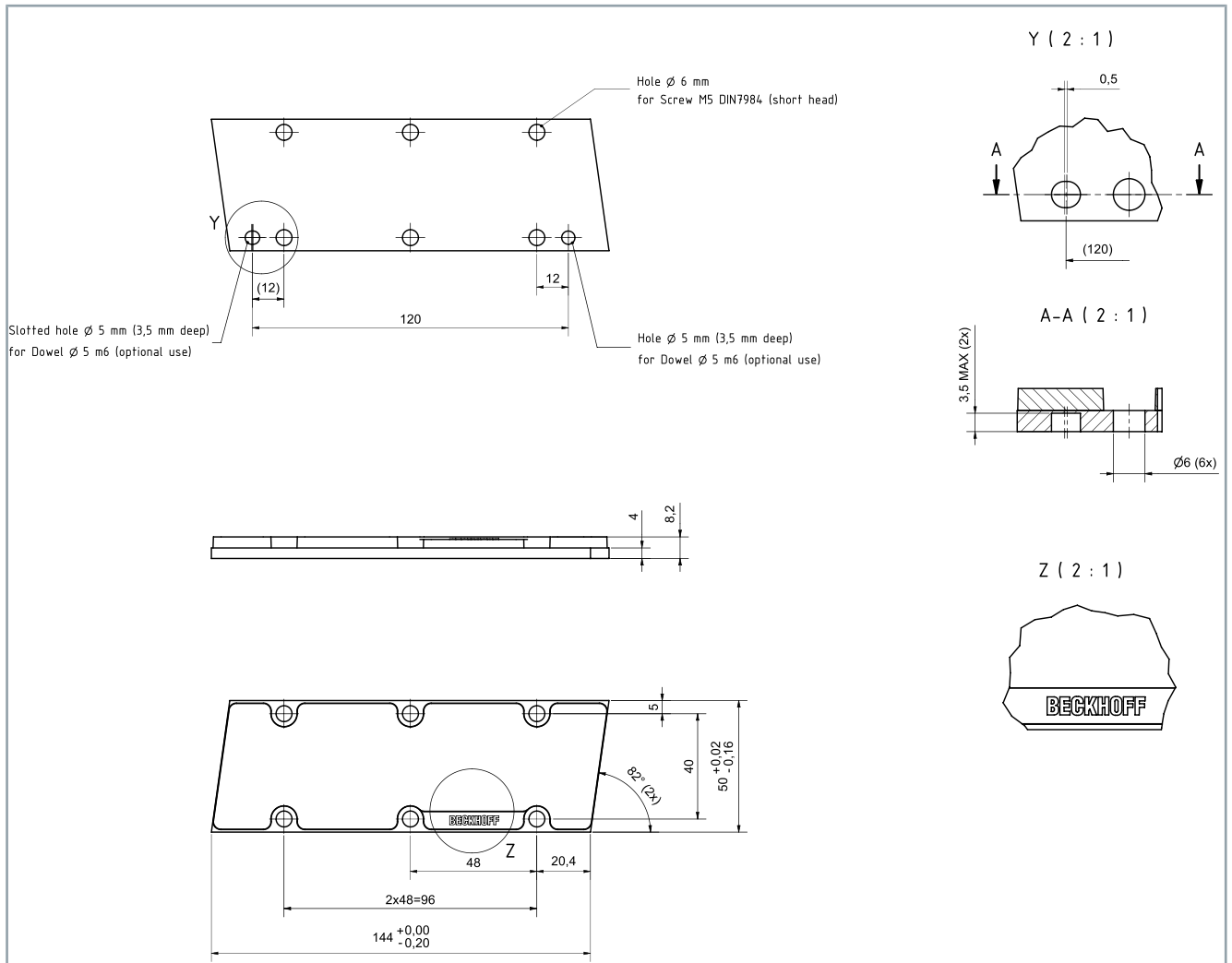

## 4.4.1.3 AL8523

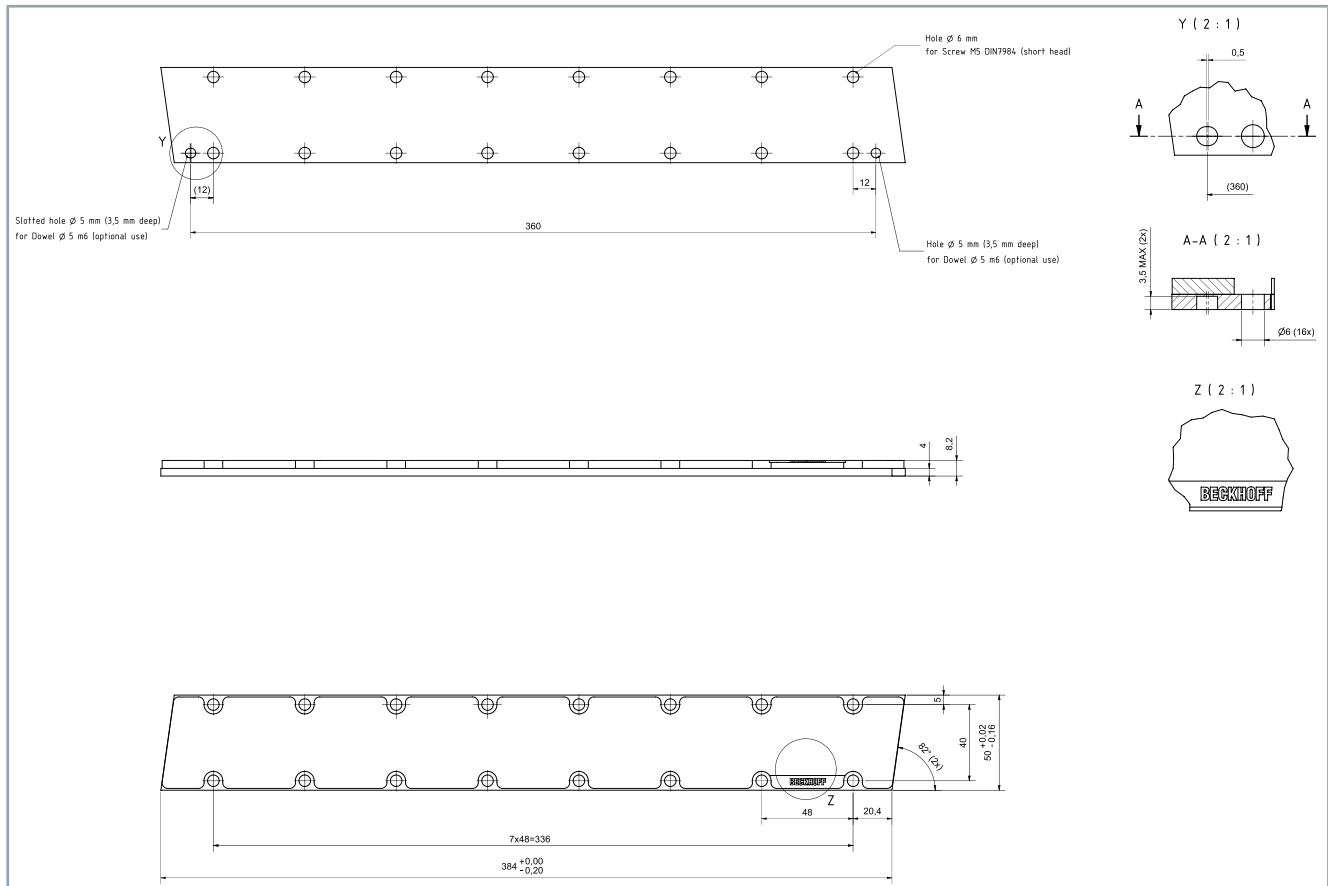

## 4.5 AL804x

Performance data	AL80					
	41-0E	42-0E	43-0E	43-0G	44-0E	44-0H
• Peak force $F_{\max}$ [N]	230	460	690	690	920	920
• Peak current $I_{\max}$ [A]	7.2	7.2	7.2	12	7.2	15
• Continuous force $F_c$ [N]	100	200	300	300	400	400
• Continuous current $I_c$ [A]	2.5	2.5	2.5	4.1	2.5	5.4
• Maximum velocity $v_{\max}$ [m/s]	7	7	3.5	7.0	3.5	7
• Force constant $K_f$ [N/A]	39	79	118	74	157	74
• Magnetic attractive force $F_a$ [N]	700	1000	1350	1350	1650	1650
• Winding resistance ph-ph [ $\Omega$ ]	4.6	9.1	14	4.9	18.2	3.8
• Winding inductance ph-ph [mH]	25	50	75	29	100	22
• Counter EMF ph-ph [V/m/s]	22	44	66	42	89	41
• Continuous power loss $P_c$ [W]	63	126	189	169	252	238
• Motor constant [N <sup>2</sup> /W]	158	317	475	531	634	673
• Thermal resistance [K/W]	0.95	0.48	0.32	0.35	0.24	0.25
• Pole pair distance [mm]	24	24	24	24	24	24
<b>Weight</b>						
• Coil unit [kg]	1.0	1.5	2	2	2.6	2.6
• Magnetic plate [kg/m]	3.8					
<b>Sensors</b>						
• Air gap [mm]	0.5					
• Temperature sensor	LPTC-600; compatible with KTY 84-130					
<b>Cable and motor data</b>						
• Outer diameter [mm]	9					
• Wire cross-section	4 x 1 mm <sup>2</sup> + 2 x AWG26					
• Minimum static bending radius	4 x outer diameter					
• Cable length, assembled [m]	0.5					
• Cable length unassembled [m]	1					
• Connector	iTec <sup>®</sup>					
<b>Recommended servo drive assignment</b>						
• AX5000	AX5x03	AX5x03	AX5x03	AX5x06	AX5x03	AX5x06
• AX8000	AX8108/AX8206					
<i>The values are valid for a linear servomotor mounted on a metal surface that is equal to or larger than that of the motor, at a surface temperature of 20°C</i>						

# Technical data

Performance data	AL80					
	45-0G	45-0K	46-0G	46-0K	48-0H	48-0K
• Peak force $F_{\max}$ [N]	1150	1150	1380	1380	1840	1840
• Peak current $I_{\max}$ [A]	12	24	12	24	15	29
• Continuous force $F_c$ [N]	500	500	600	600	800	800
• Continuous current $I_c$ [A]	4.1	8.5	4.1	8.5	5.4	10
• Maximum velocity $v_{\max}$ [m/s]	3.5	7	3.5	7	3.5	7
• Force constant $K_f$ [N/A]	123	59	148	71	147	79
• Magnetic attractive force $F_a$ [N]	2050	2050	2400	2400	3200	3200
• Winding resistance ph-ph [ $\Omega$ ]	8.1	2	9.7	2.4	7.6	2.2
• Winding inductance ph-ph [mH]	49	11	59	13	44	12
• Counter EMF ph-ph [V/m/s]	69	33	83	40	83	44
• Continuous power loss $P_c$ [W]	282	298	339	358	476	458
• Motor constant [N <sup>2</sup> /W]	885	839	1062	1006	1346	1398
• Thermal resistance [K/W]	0.21	0.20	0.18	0.17	0.13	0.13
• Pole pair distance [mm]	24	24	24	24	24	24
<b>Weight</b>						
• Coil unit [kg]	3.2	3.2	3.8	3.8	4.9	4.9
• Magnetic plate [kg/m]	3.8					
<b>Sensors</b>						
• Air gap [mm]	0.5					
• Temperature sensor	LPTC-600; compatible with KTY 84-130					
<b>Cable and motor data</b>						
• Outer diameter [mm]	9	9.5	9	9.5	9	9.5
• Wire cross-section	4 x 1 mm <sup>2</sup> + 2 x AWG26	4 x 1.5 mm <sup>2</sup> + 2 x AWG26	4 x 1 mm <sup>2</sup> + 2 x AWG26	4 x 1.5 mm <sup>2</sup> + 2 x AWG26	4 x 1 mm <sup>2</sup> + 2 x AWG26	4 x 1.5 mm <sup>2</sup> + 2 x AWG26
• Minimum static bending radius	4 x outer diameter					
• Cable length, assembled [m]	0.5					
• Cable length unassembled [m]	1					
• Connector	iTec®	M23- Speedtec®	iTec®	M23- Speedtec®	iTec®	M23- Speedtec®
<b>Recommended servo drive assignment</b>						
• AX5000	AX5x06	AX5112	AX5x06	AX5112	AX5x06	AX5112
• AX8000	AX8108 AX8206	AX8108	AX8108 AX8206	AX8108	AX8108 AX8206	AX8108
<i>The values are valid for a linear servomotor mounted on a metal surface that is equal to or larger than that of the motor, at a surface temperature of 20°C</i>						



## 4.5.1 Dimensional drawings

- All figures in millimeters

### Water cooling:

- 4x connections for water cooling channel

### Hole:

- 5 mm diameter, 4 mm depth for locating pin ISO 8734

### Tapped hole:

- M5 thread, 6 mm depth

### Elongated hole:

- 5 x 0.5 mm diameter, 4 mm depth for locating pin ISO 8734

### 4.5.1.1 AL8041

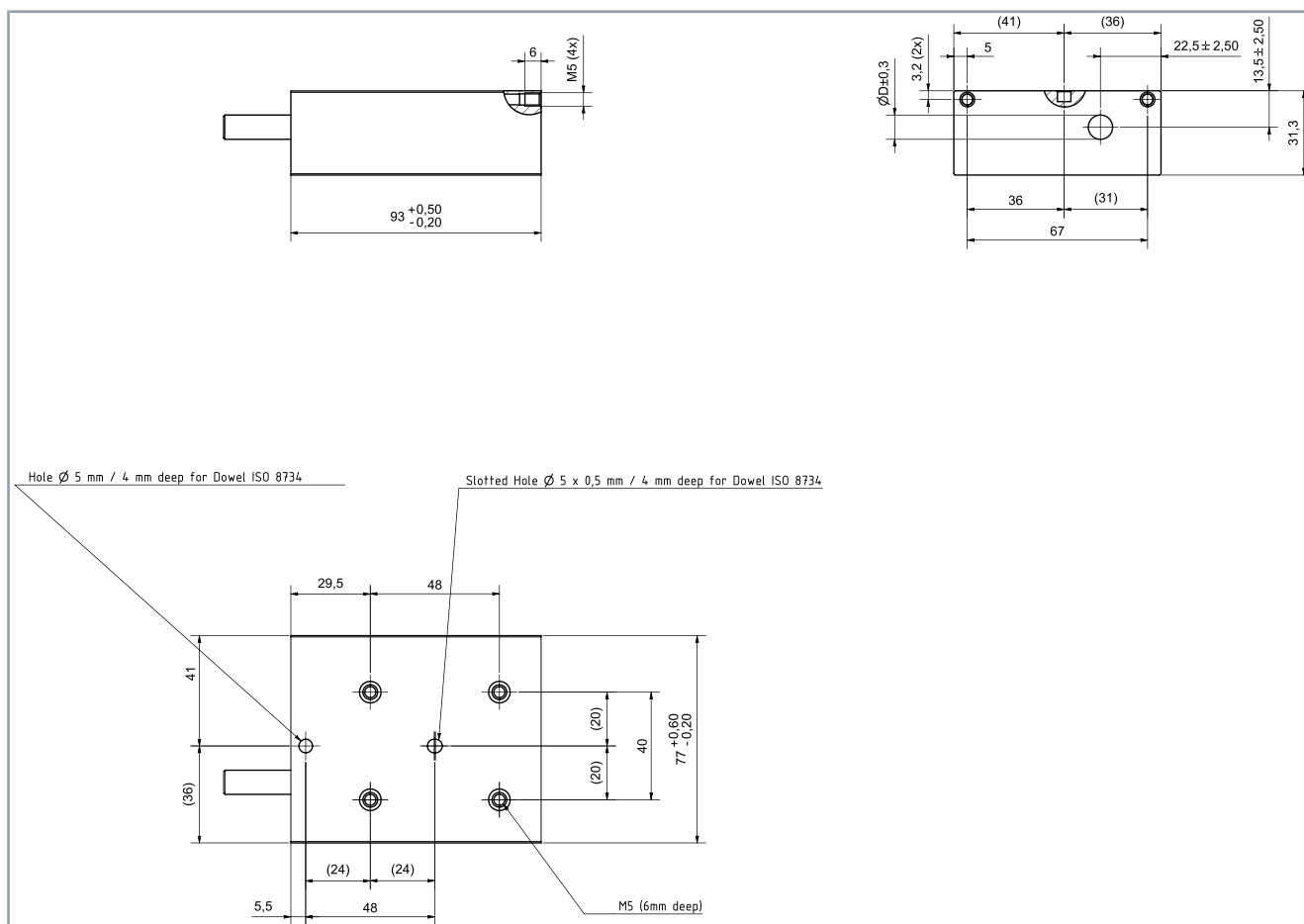

## 4.5.1.2 AL8042

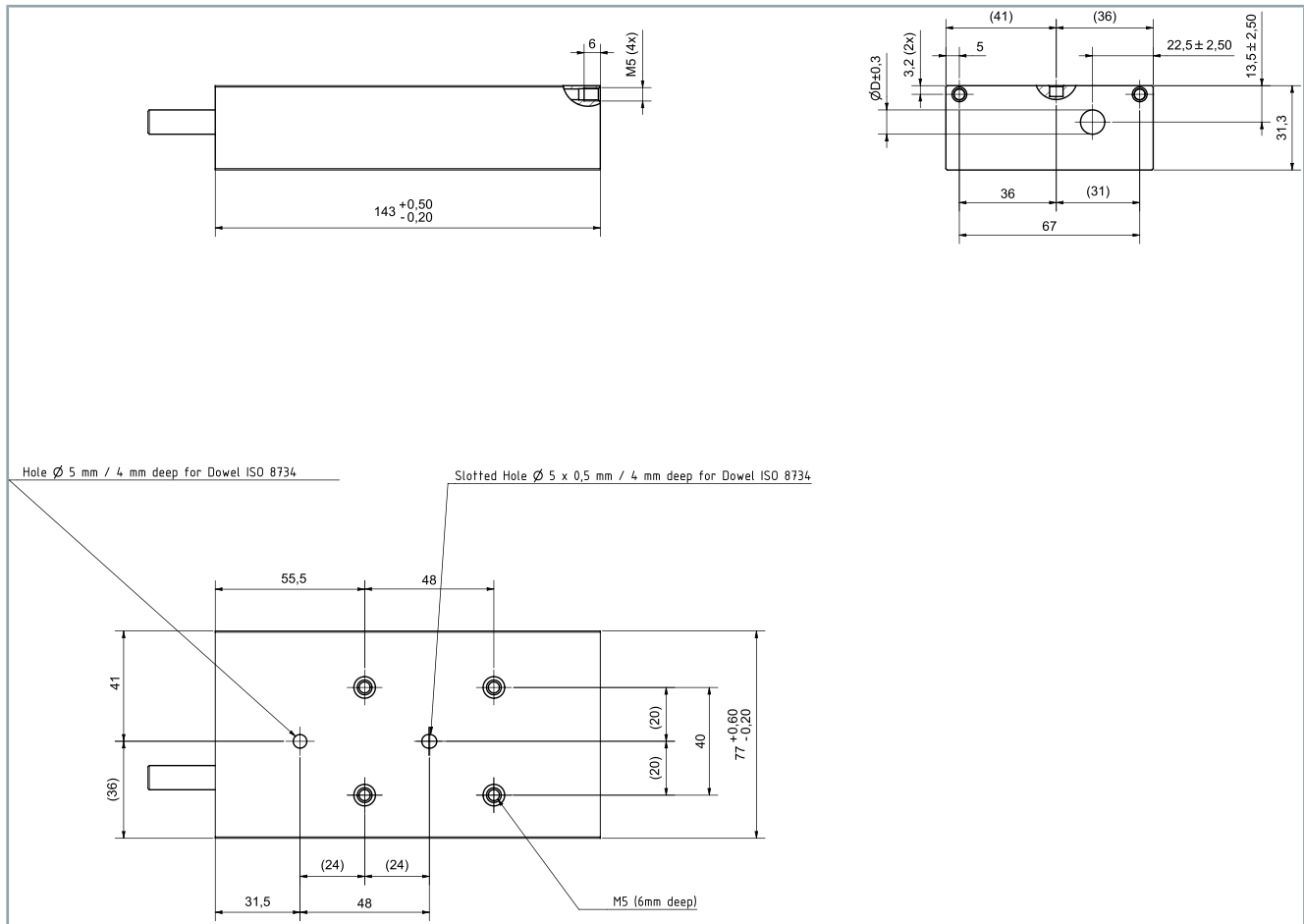

4.5.1.3 AL8043

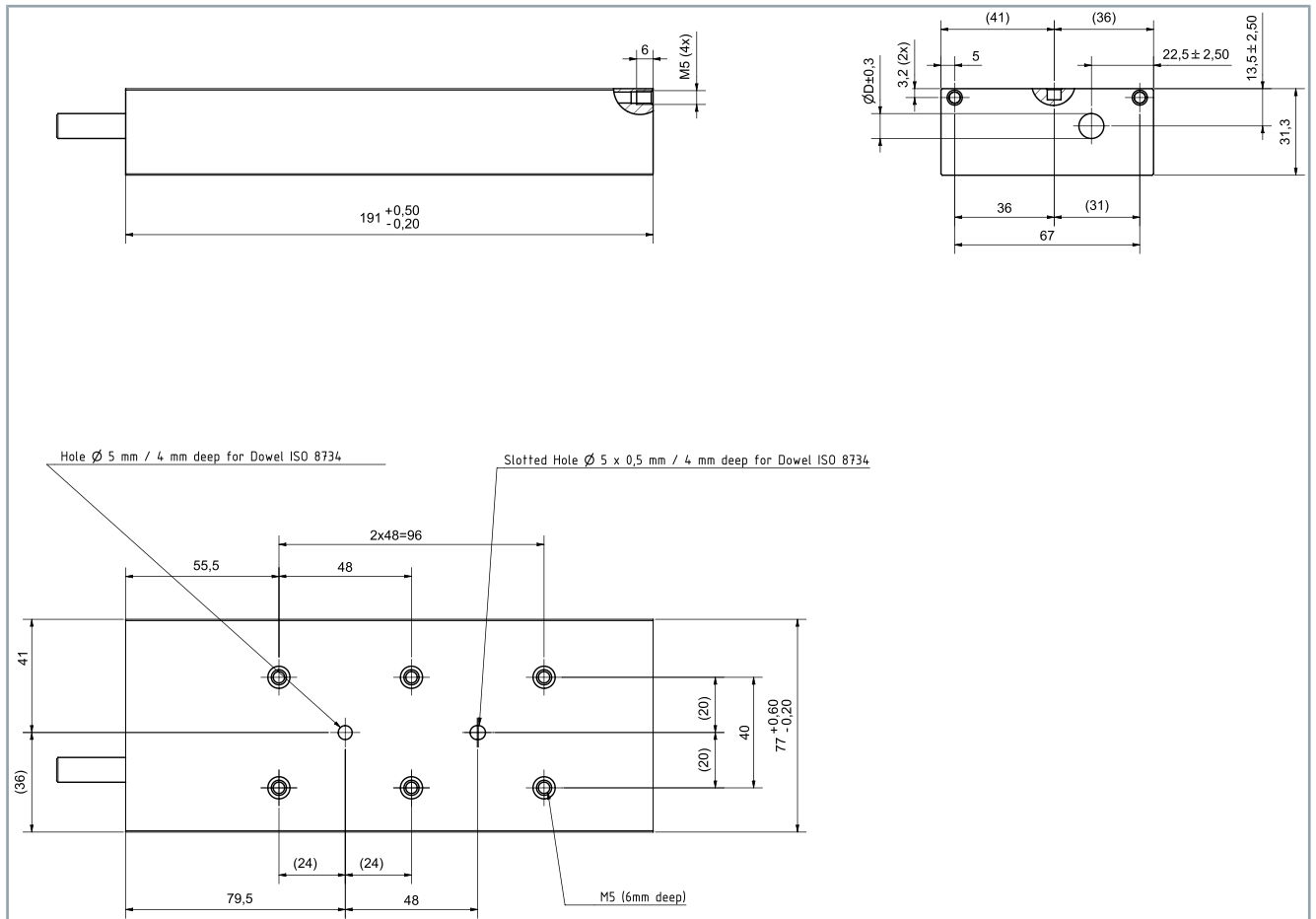



4.5.1.5 AL8045

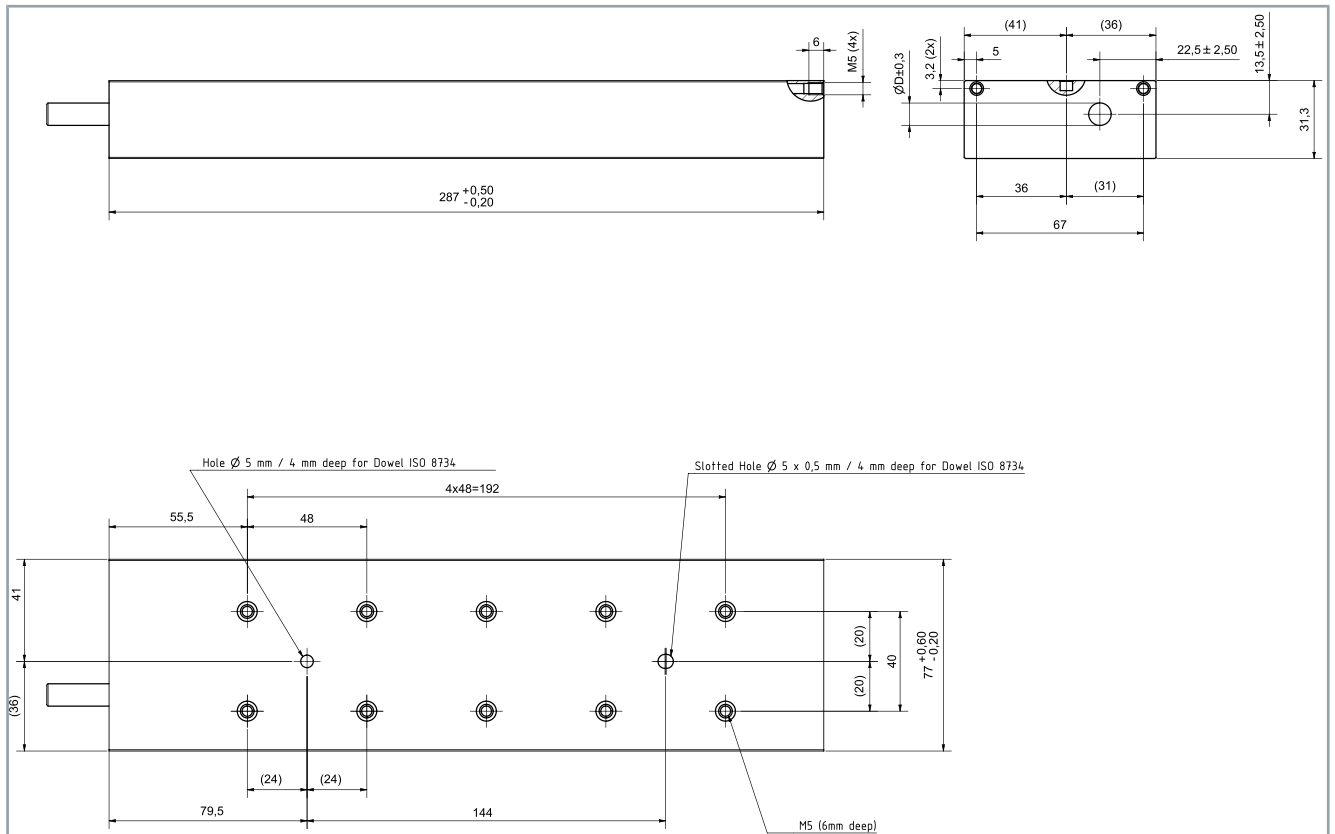

4.5.1.6 AL8046

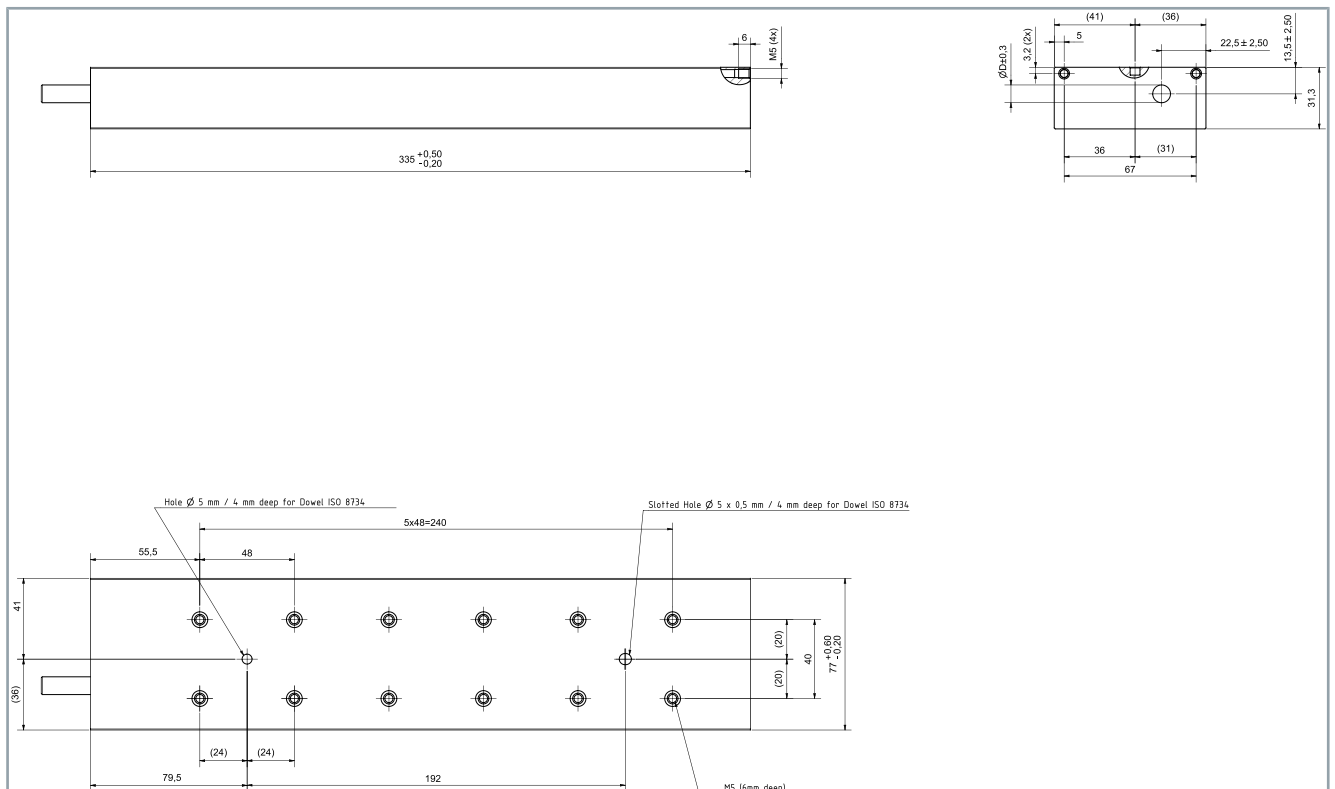

## 4.5.1.7 AL8048

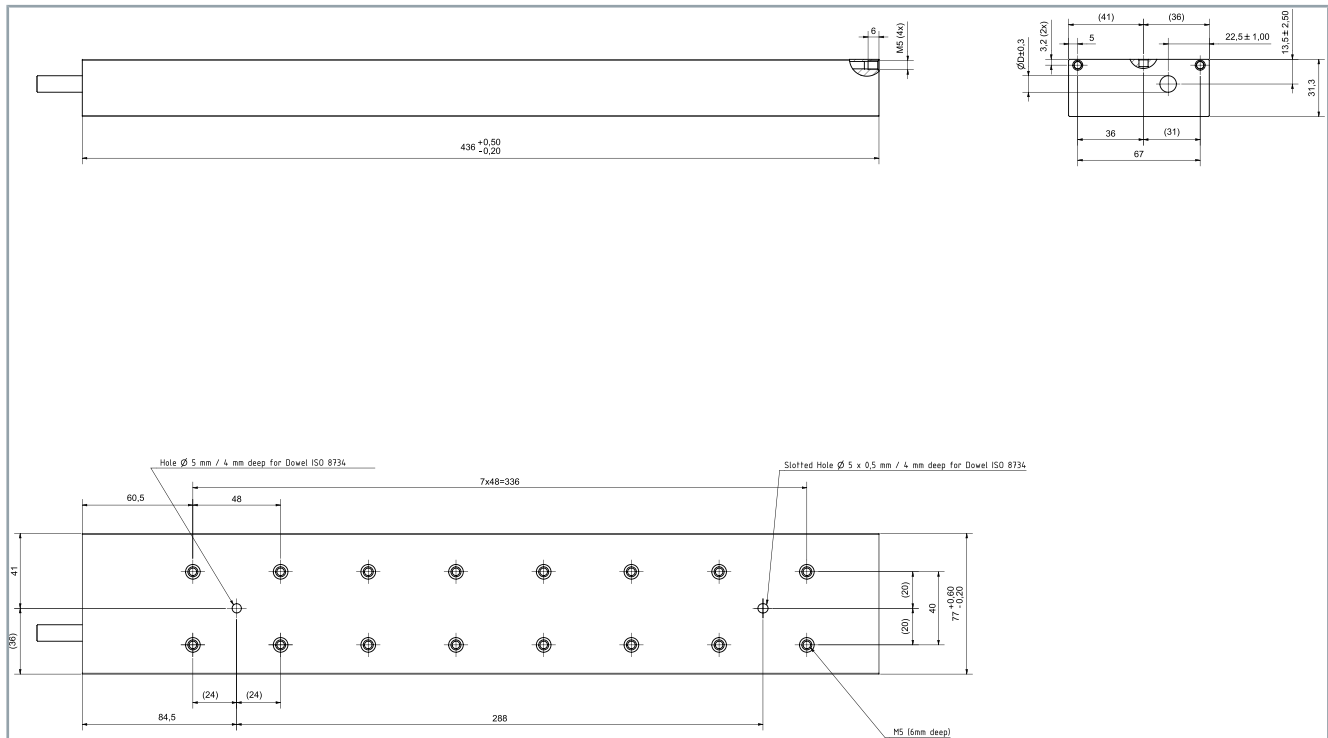

## 4.5.2 AL804x alignment



### Alignment based on AL804x as an example

The figure shows the positioning of a coil part in relation to the magnetic track.

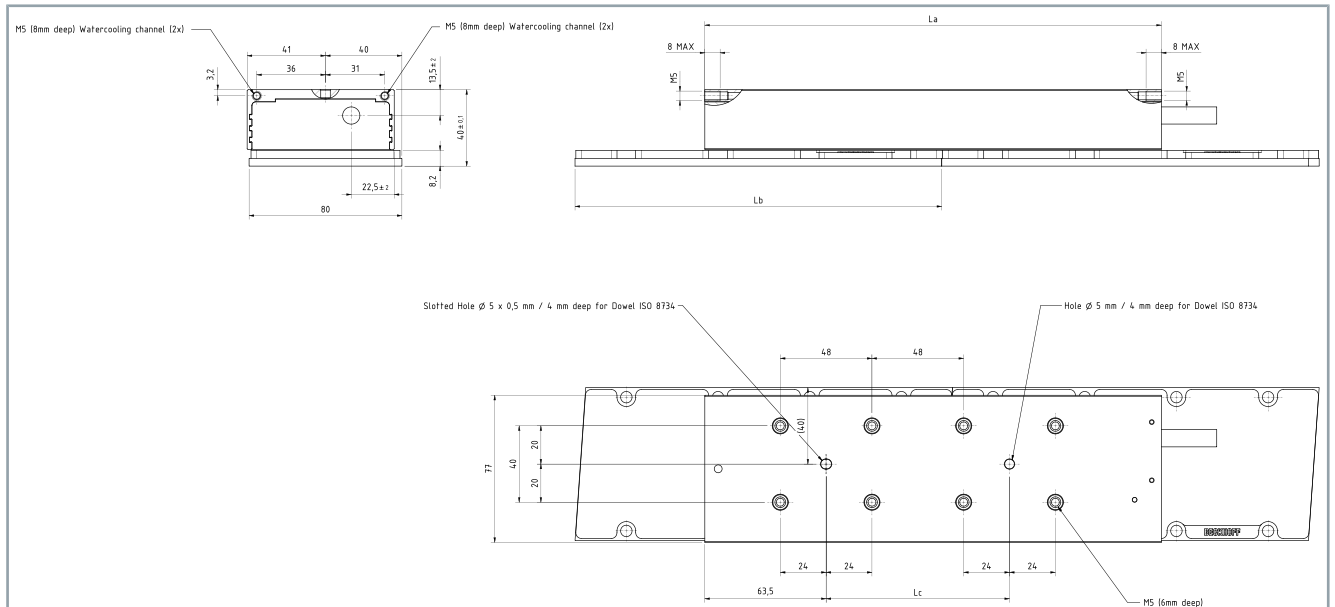

## 4.6 AL854x magnetic plates

### 4.6.1 Dimensional drawings

- All figures in millimeters

#### Hole:

- 6 mm diameter for screw M5 DIN7984, short head
- 5 mm diameter, 3.5 mm depth for locating pin with diameter 5 m6

#### Elongated hole:

- 5 mm x 0.5 mm diameter, 3.5 mm depth for locating pin with diameter 5 m6

#### 4.6.1.1 AL8541

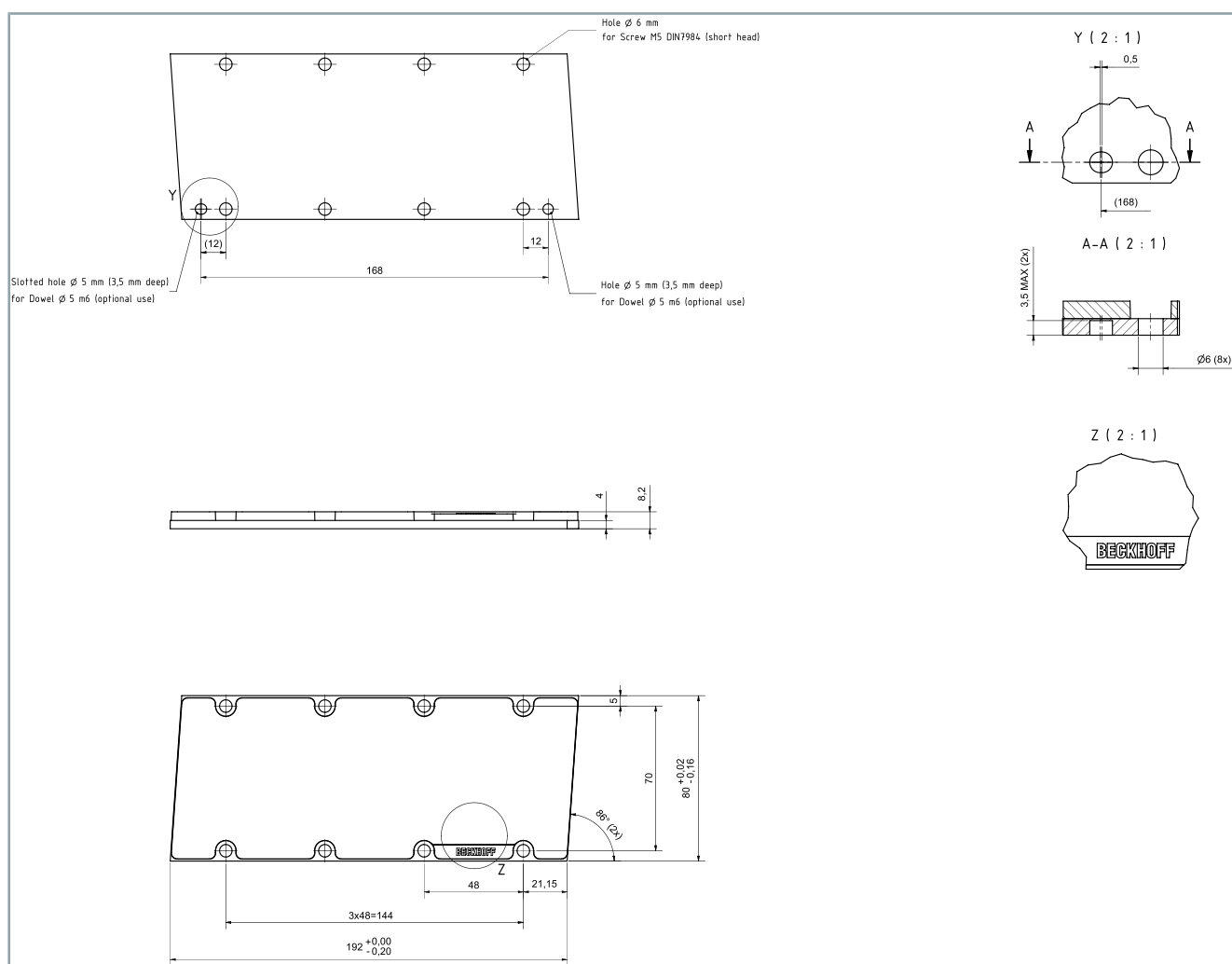



4.6.1.2 AL8542

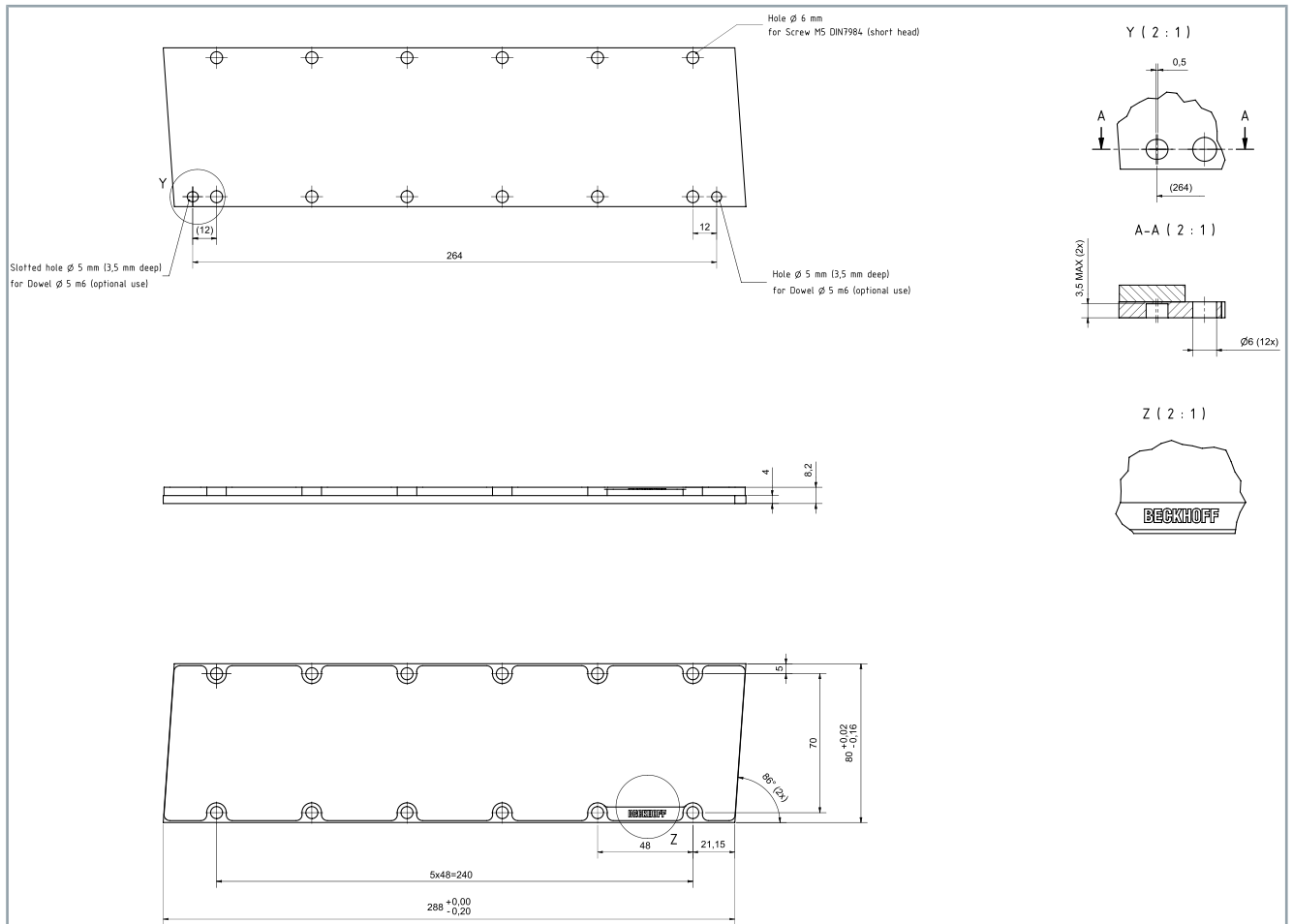

## 4.7 AL806x-0

- Coil part with convection cooling

Performance data	AL80					
	64-0F	64-0K	65-0H	65-0K	6A-0K	6A-0Q
• Peak force $F_{\max}$ [N]	1800	1800	2250	2250	4500	4500
• Peak current $I_{\max}$ [A]	12	24	15	24	24	72
• Continuous force $F_c$ [N]	760	760	950	950	1900	1900
• Continuous current $I_c$ [A]	4.0	8.3	5.3	8.3	8.3	25
• Maximum velocity $v_{\max}$ [m/s]	3	6	3	6	3	6
• Force constant $K_f$ [N/A]	191	91	178	114	228	76
• Magnetic attractive force $F_a$ [N]	3200	3200	3950	3950	7500	7500
• Winding resistance ph-ph [ $\Omega$ ]	11.5	2.75	8.2	3.3	6.7	0.9
• Winding inductance ph-ph [mH]	77	18	53	22	44	5
• Counter EMF ph-ph [V/m/s]	108	52	101	65	130	43
• Continuous power loss $P_c$ [W]	366	394	483	493	986	1084
• Motor constant [N <sup>2</sup> /W]	1579	1465	1867	1831	3662	3329
• Thermal resistance [K/W]	0.16	0.15	0.12	0.12	0.06	0.06
• Pole pair distance [mm]	24	24	24	24	24	24
<b>Weight</b>						
• Coil unit [kg]	4.9	4.9	5.9	5.9	11.4	11.4
• Magnetic plate [kg/m]	10.5					
<b>Sensors</b>						
• Air gap [mm]	0.5					
• Temperature sensor	LPTC-600; compatible with KTY 84-130					
<b>Cable and motor data</b>						
• Outer diameter [mm]	9	9.5	9	9.5	9.5	12.2
• Wire cross-section	4 x 1 mm <sup>2</sup> + 2 x AWG26	4 x 1.5 mm <sup>2</sup> + 2 x AWG26	4 x 1 mm <sup>2</sup> + 2 x AWG26	4 x 1.5 mm <sup>2</sup> + 2 x AWG26	4 x 1.5 mm <sup>2</sup> + 2 x AWG26	4 x 4 mm <sup>2</sup> + 2 x AWG26
• Minimum static bending radius	4 x outer diameter					
• Cable length, assembled [m]	0.5					
• Cable length unassembled [m]	1					
• Connector	iTec <sup>®</sup>	M23- Speedtec <sup>®</sup>	iTec <sup>®</sup>	M23- Speedtec <sup>®</sup>	M23- Speedtec <sup>®</sup>	M40- Speedtec <sup>®</sup>
<b>Recommended servo drive assignment</b>						
• AX5000	AX5x06	AX5112	AX5x06	AX5112	AX5112	AX5125
• AX8000	AX8108 AX8206	AX8108	AX8108 AX8206	AX8108	AX8108	AX8525
<i>The values are valid for a linear servomotor mounted on a metal surface that is equal to or larger than that of the motor, at a surface temperature of 20°C</i>						

### 4.7.1 Dimensional drawings

- All figures in millimeters

#### Hole:

- 5 mm diameter, 4 mm depth for locating pin ISO 8734

#### Tapped hole:

- M5 thread, 6 mm depth

**Elongated hole:**

- 5 x 0.5 mm diameter, 4 mm depth for locating pin ISO 8734

4.7.1.1 AL8064

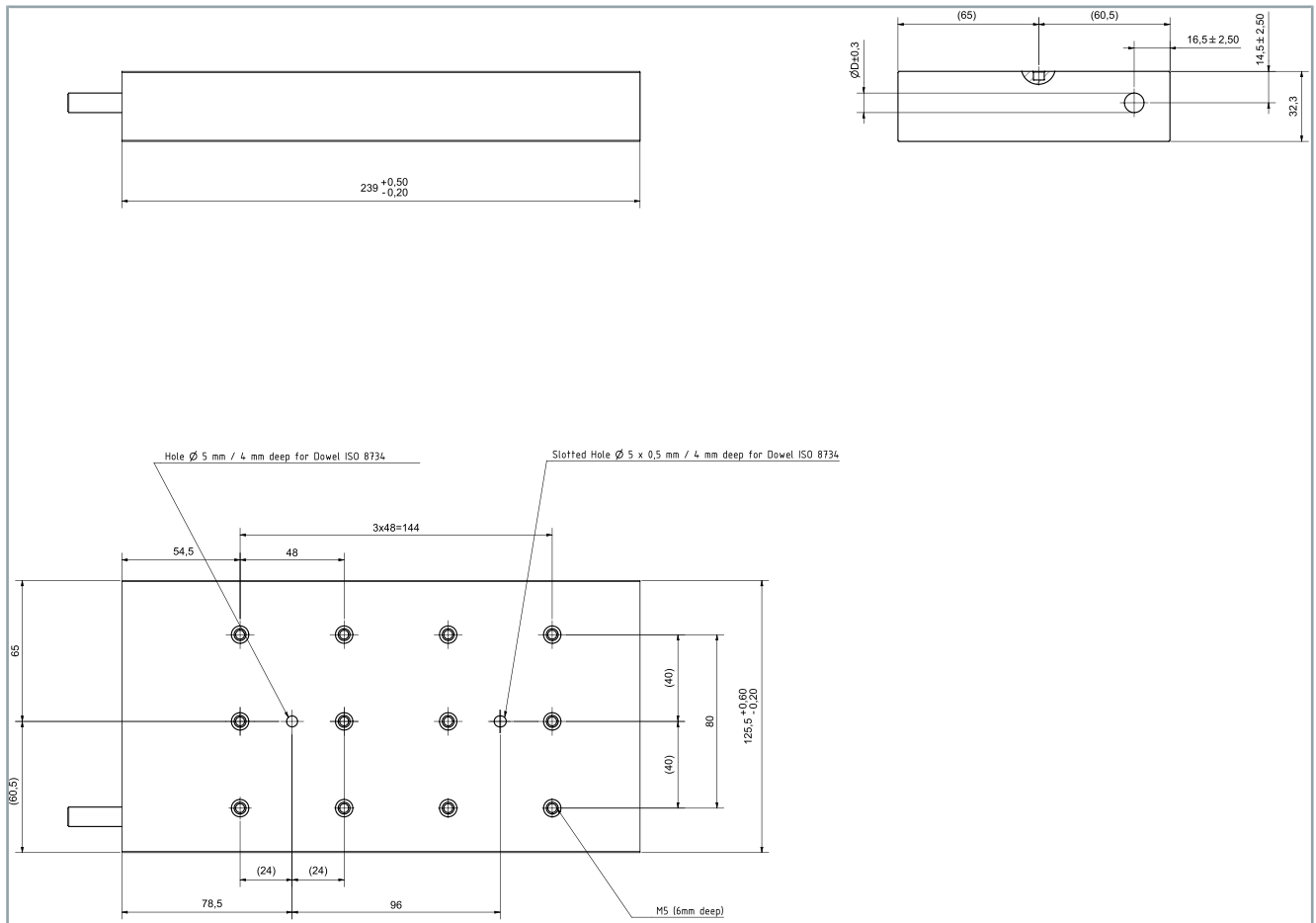

## 4.7.1.2 AL8065

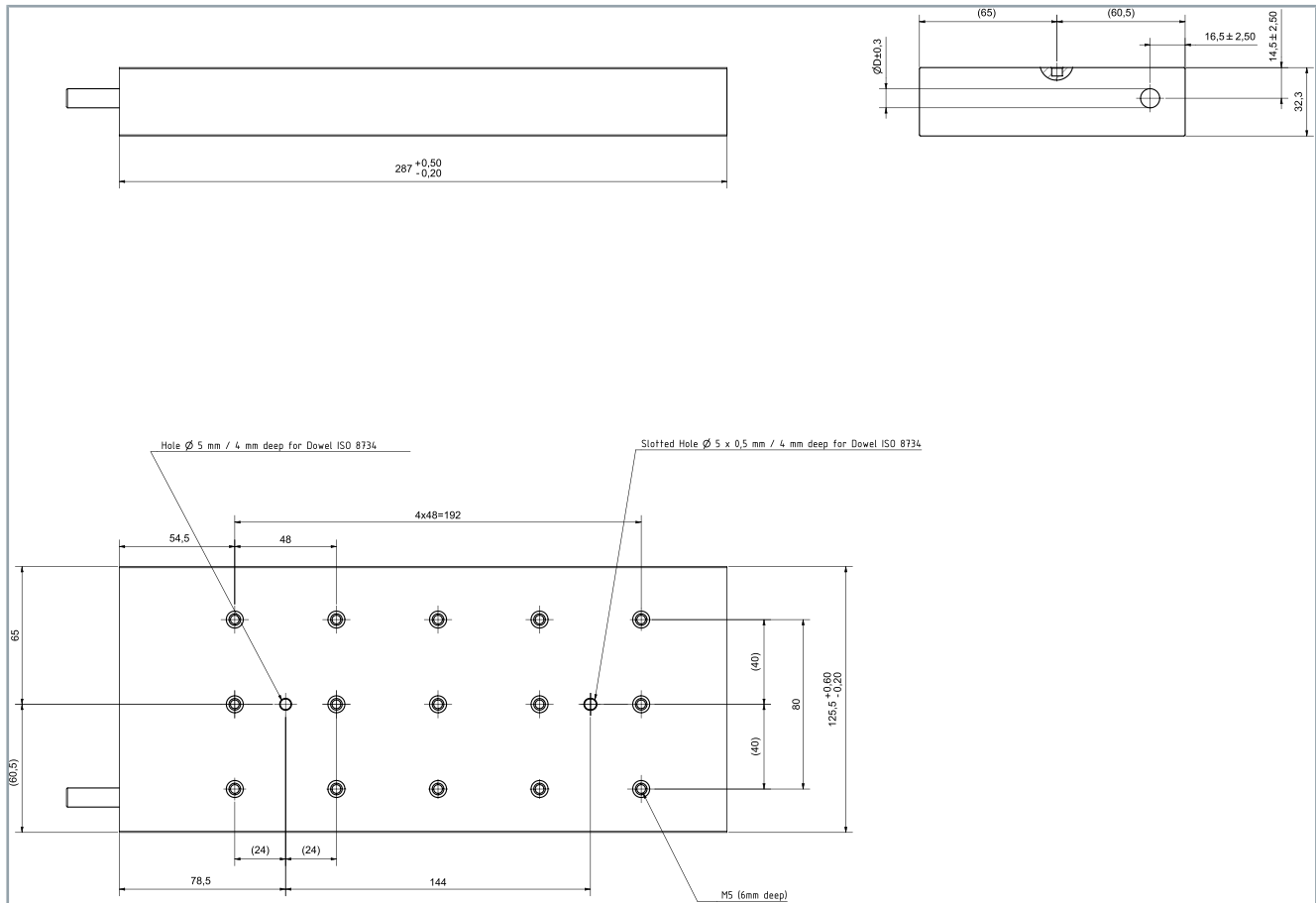

4.7.1.3 AL806A

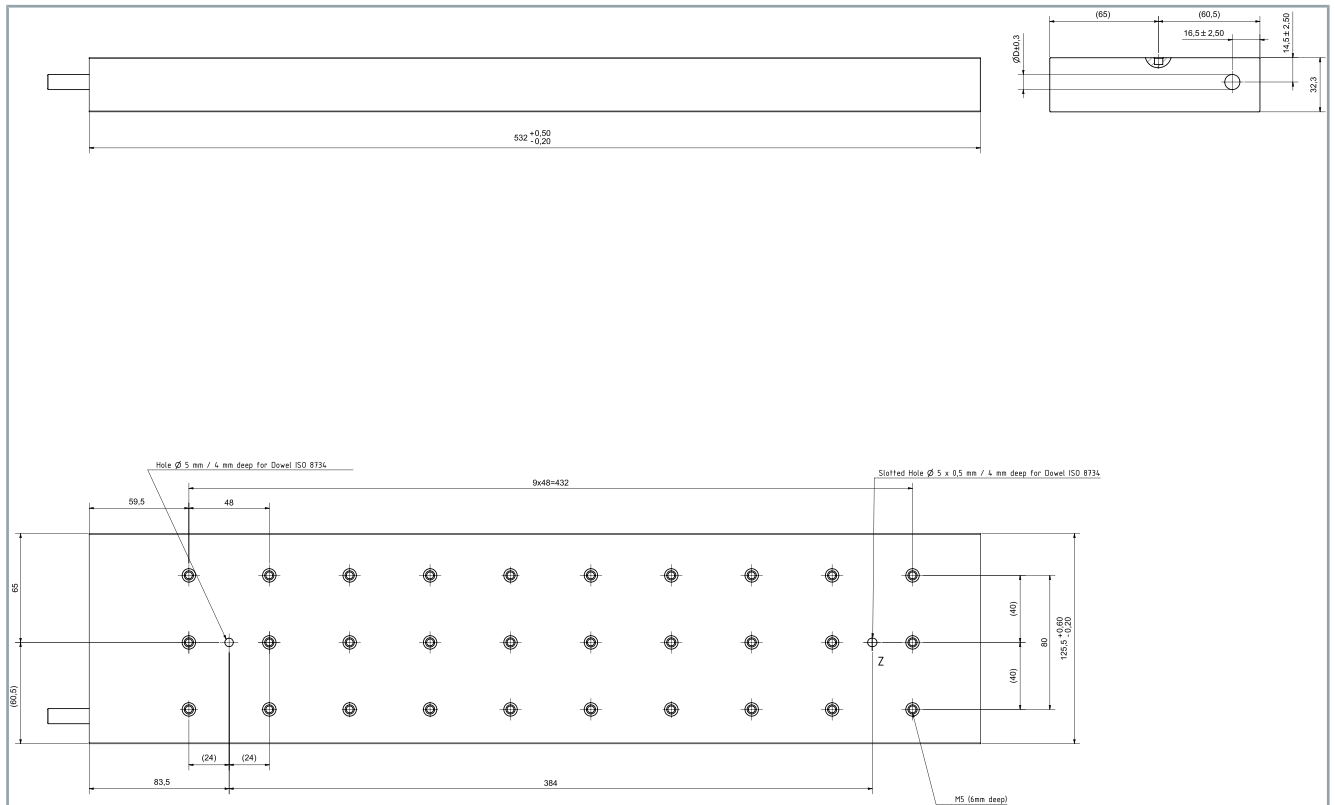



## 4.8 AL806x-1

- Coil part with water cooling

Performance data	AL80						
	66-1J	66-1N	6A-1K	6A-1R	6B-1L	6F-1N	6F-1T
• Peak force $F_{\max}$ [N]	2700	2700	4500	4500	4950	6750	6750
• Peak current $I_{\max}$ [A]	18	42	24	72	29	42	100
• Continuous force $F_c$ [N]	1200	1200	2000	2000	2200	3000	3000
• Continuous current $I_c$ [A]	6.4	15	8.8	26	10.5	15	36
• Maximum velocity $v_{\max}$ [m/s]	3	6	3	6	3	3	6
• Force constant $K_f$ [N/A]	186	79	228	76	209	197	83
• Magnetic attractive force $F_a$ [N]	4650	4650	7500	7500	8250	11250	11250
• Winding resistance ph-ph [ $\Omega$ ]	8	1.4	6.7	0.9	5.2	3.6	0.8
• Winding inductance ph-ph [mH]	49	9	44	5	34	22	4
• Counter EMF ph-ph [V/m/s]	106	45	130	43	119	112	47
• Continuous power loss $P_c$ [W]	658	661	1096	1206	1140	1654	1710
• Motor constant [N <sup>2</sup> /W]	2187	2177	3649	3317	4245	5443	5263
• Thermal resistance [K/W]	0.09	0.09	0.05	0.05	0.05	0.04	0.04
• Pole pair distance [mm]	24	24	24	24	24	24	24
<b>Weight</b>							
• Coil unit [kg]	7.4	7.4	11.5	11.5	12.7	16.8	16.8
• Magnetic plate [kg/m]	10.5						
<b>Sensors</b>							
• Air gap [mm]	0.5						
• Temperature sensor	LPTC-600; compatible with KTY 84-130						
<b>Cable and motor data</b>							
• Outer diameter [mm]	9.5	10.9	9.5	12.2	10.9	10.9	12.2
• Wire cross-section	4 x 1.5 mm <sup>2</sup> + 2 x AWG26	4 x 2.5 mm <sup>2</sup> + 2 x AWG26	4 x 1.5 mm <sup>2</sup> + 2 x AWG26	4 x 4.0 mm <sup>2</sup> + 2 x AWG26	4 x 2.5 mm <sup>2</sup> + 2 x AWG26	4 x 2.5 mm <sup>2</sup> + 2 x AWG26	4 x 4.0 mm <sup>2</sup> + 2 x AWG26
• Minimum static bending radius	4 x outer diameter						
• Cable length, assembled [m]	0.5						
• Cable length unassembled [m]	1						
• Connector	M23- Speedtec ®	M23- Speedtec ®	M23- Speedtec ®	M40- Speedtec ®	M23- Speedtec ®	M23- Speedtec ®	M40- Speedtec ®
<b>Recommended servo drive assignment</b>							
• AX5000	AX5106 AX5112	AX5118	AX5112	AX5125	AX5112 AX5118	AX5118	AX5140
• AX8000	AX8108 AX8206	AX8118	AX8108	AX8525	AX8118	AX8118	AX8540
<i>The values are valid for a linear servomotor mounted on a metal surface that is equal to or larger than that of the motor, at a surface temperature of 20°C</i>							

### 4.8.1 Dimensional drawings

- All figures in millimeters

#### Water cooling:

- 2x connections water cooling channel G1/8", 8 mm depth

## Hole:

- 5 mm diameter, 4 mm depth for locating pin ISO 8734

## Tapped hole:

- M5 thread, 6 mm depth

## Elongated hole:

- 5 x 0.5 mm diameter, 4 mm depth for locating pin ISO 8734

### 4.8.1.1 AL8066-1

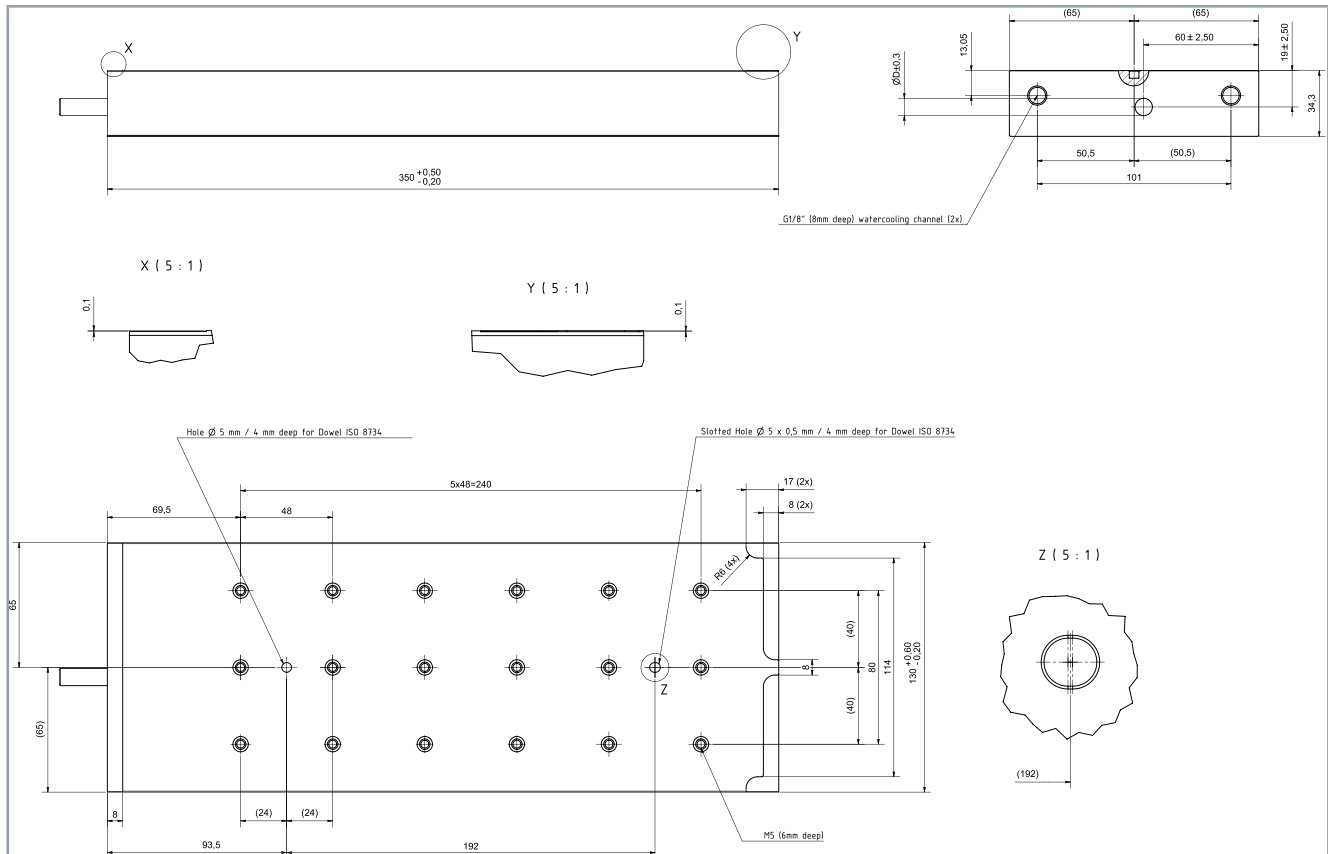



4.8.1.2 AL806A-1

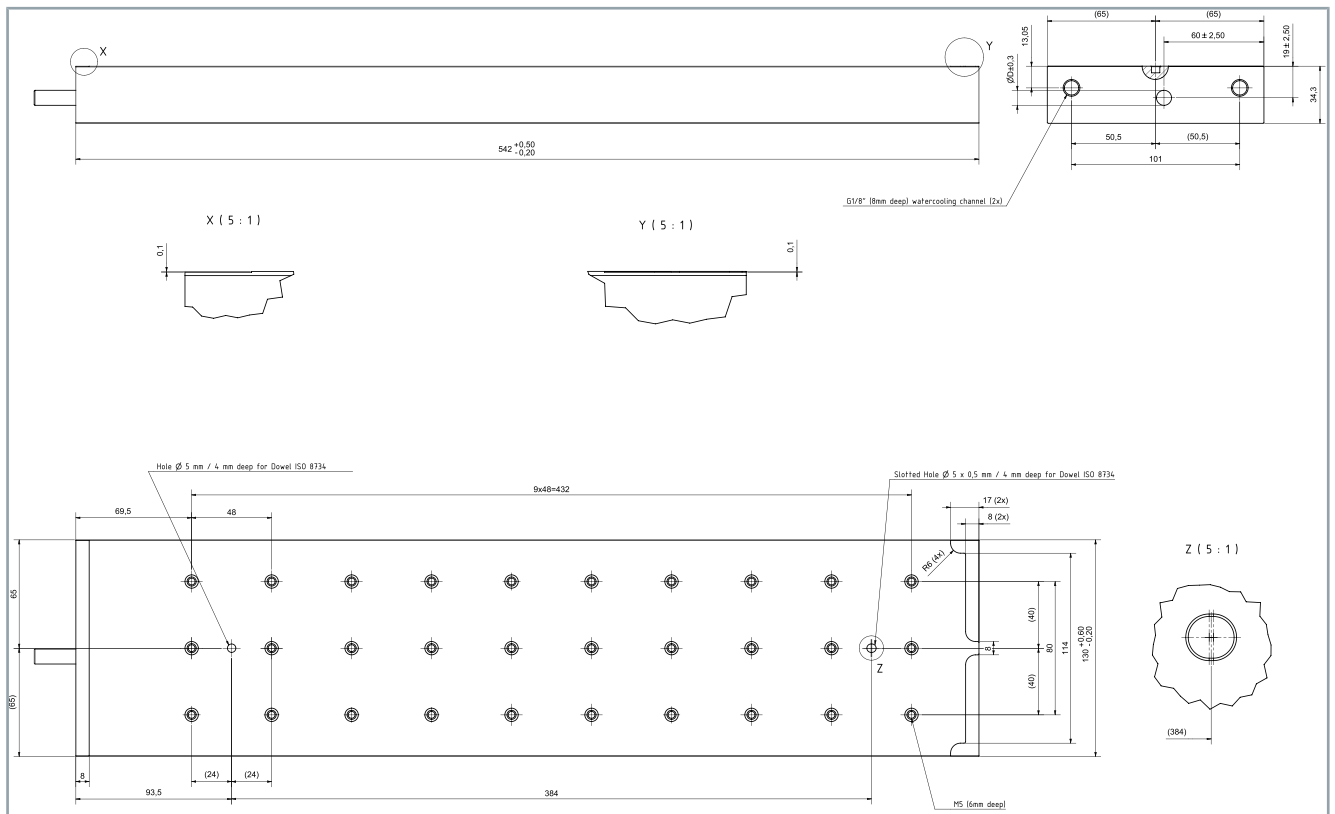

## 4.8.1.3 AL806B-1

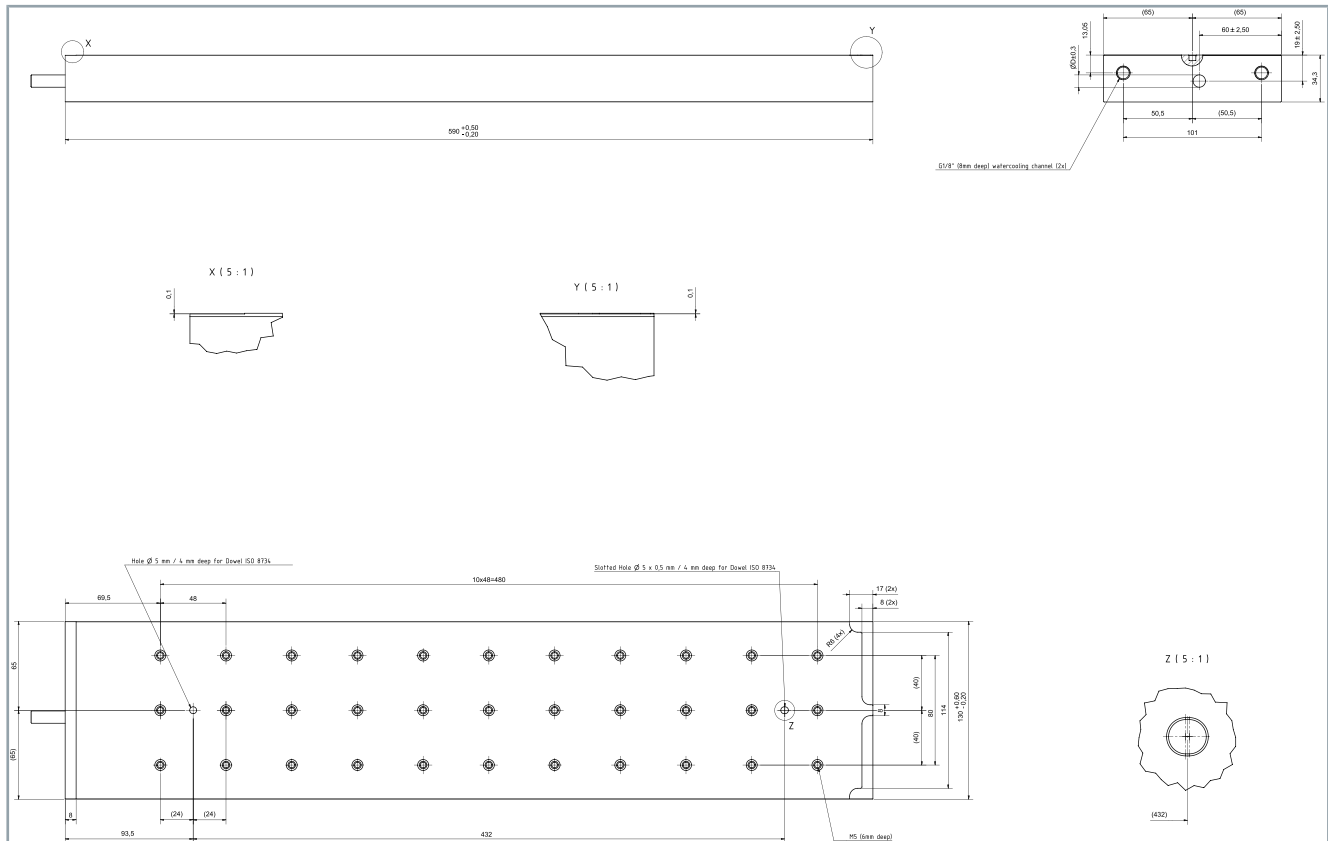



## 4.8.2 AL806x-1 alignment



### Alignment based on AL806x-1 as an example

The figure shows the positioning of a coil part in relation to the magnetic track.

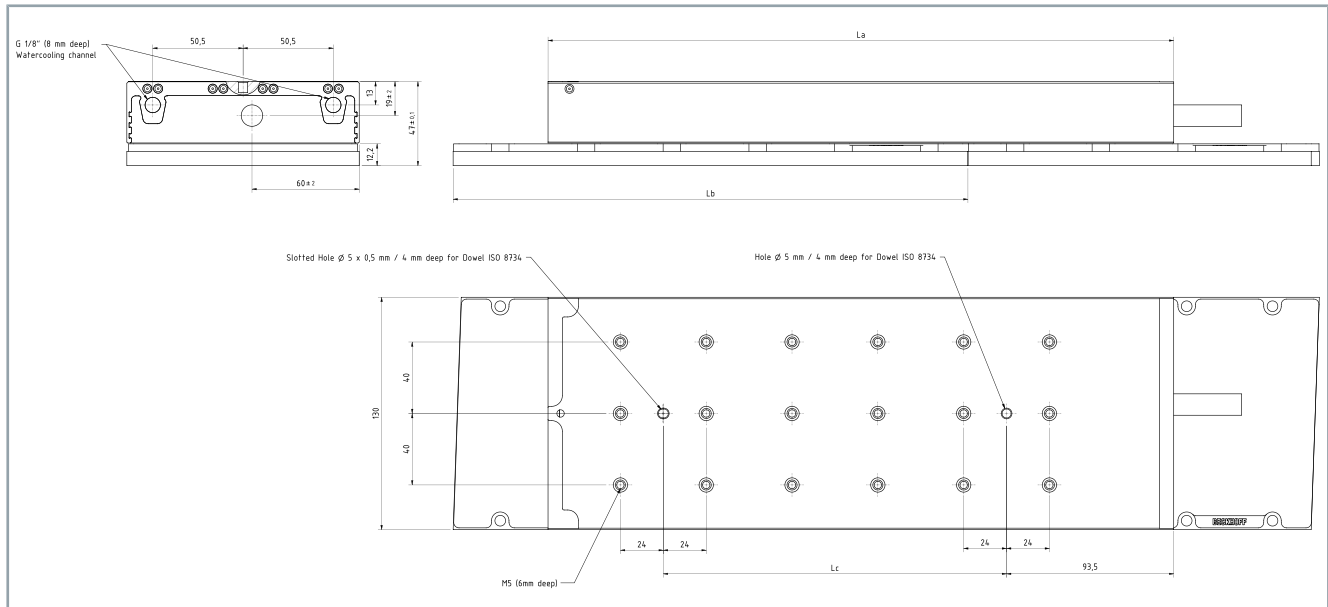

## 4.9 AL856x magnetic plates

### 4.9.1 Dimensional drawings

- All figures in millimeters

#### Hole:

- 6 mm diameter for screw M5 DIN7984, short head
- 5 mm diameter, 6 mm depth for locating pin with diameter 5 m6

#### Elongated hole:

- 5 mm x 0.5 mm diameter, 6 mm depth for locating pin with diameter 5 m6

#### 4.9.1.1 AL8561

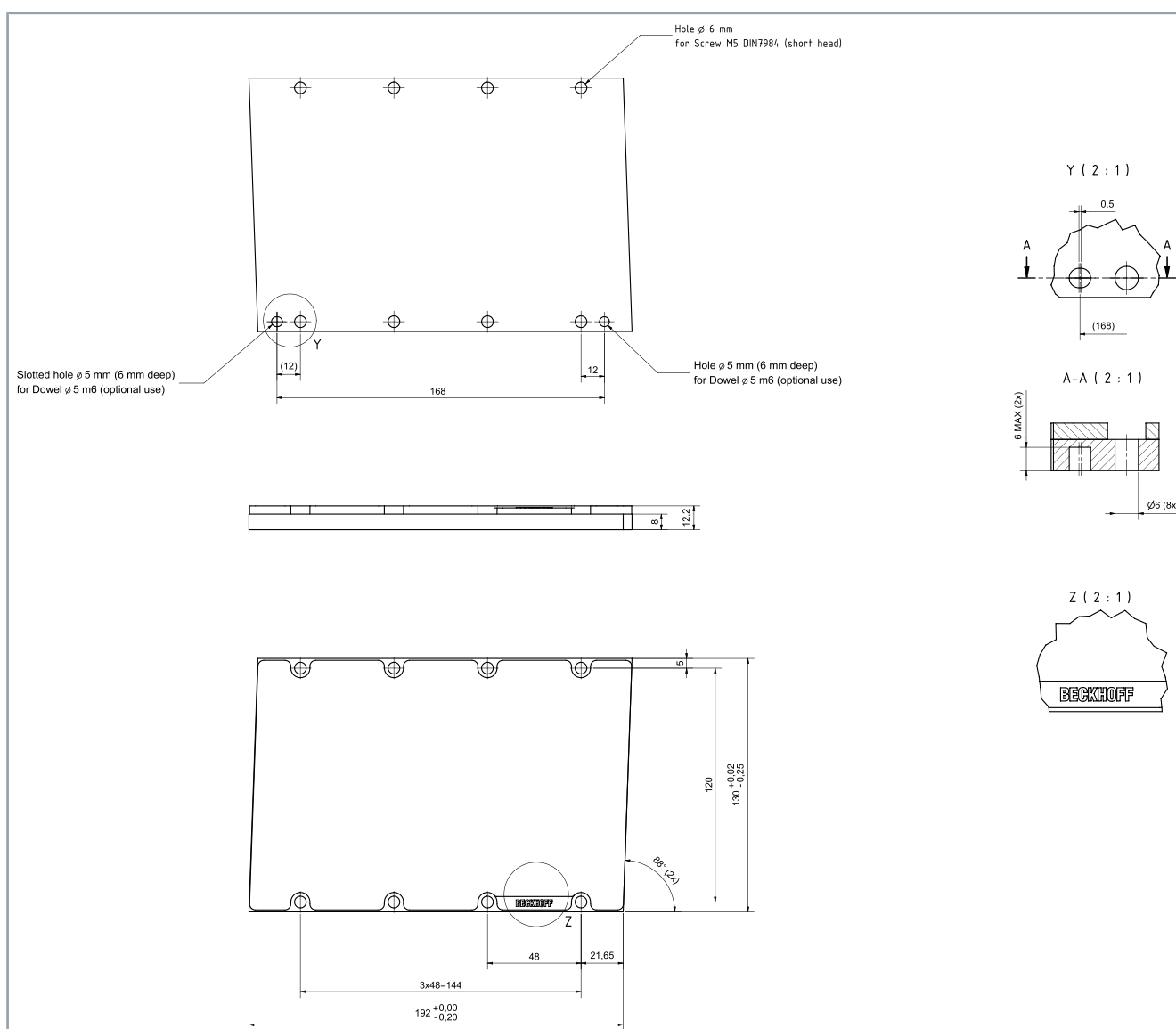

## 4.9.1.2 AL8562

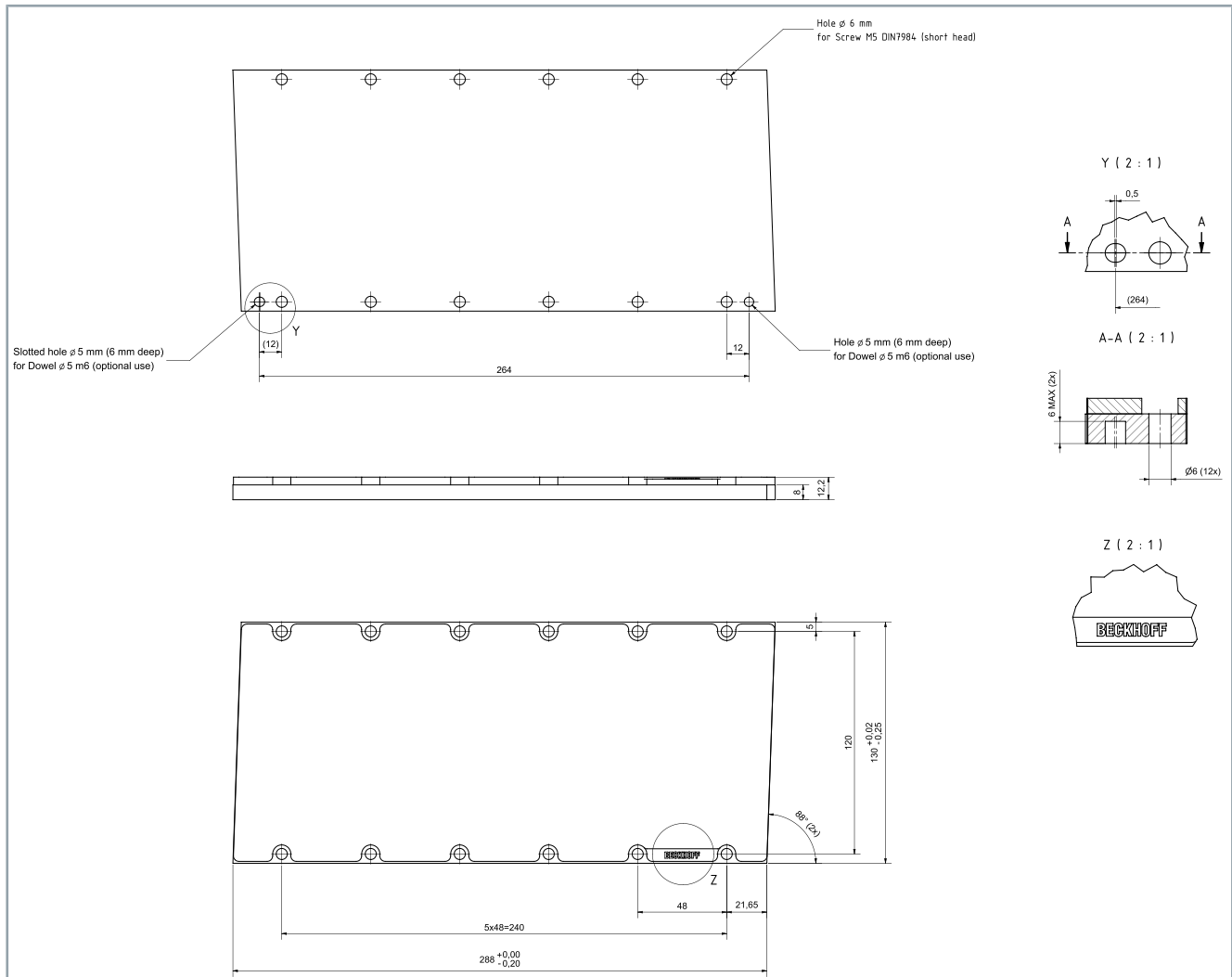

## 5 Scope of supply



### Check the scope of supply for missing or damaged parts

Check your delivery for completeness. If any parts are missing or became damaged during transport, contact the carrier, vendor or our service department immediately.

Check the shipment for the following contents:

#### When ordering a coil part:

- AL8000 series coil part
- 2x adhesive name plates
- Translation of the original instructions; this documentation

#### When ordering a magnetic plate:





- AL85xx series magnetic plate with protective cover, without fixing material
- Short information

## 5.1 Packaging

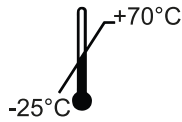

The coil parts and magnetic plates are individually packed and delivered separately.

Instructions for handling are printed on the packaging:

### 5.1.1 Linear servomotor

Symbol	Explanation
	These are the permitted maximum and minimum temperatures at which the device may be stored and transported.
	This is the correct position for the packaging.
	Protect the packaging against wetness.
	The contents are fragile.

## 5.1.2 Magnetic plate

Symbol	Explanation
	This symbol indicates magnetic fields. Devices that are sensitive to magnetic fields must be moved out of range.
	Persons with cardiac pacemakers are particularly at risk from the magnetic field.
	Persons with implants are particularly at risk from the magnetic field.



## 6 Transport and storage

### NOTICE

**Avoid damage to the coil parts and resulting loss of warranty**

Observe the conditions and the following chapters on transport and storage.

*Failure to observe the conditions may result in damage to the coil parts and void the warranty.*

### NOTICE

**Do not remove silver protective cover**

Do not remove the silver protective cover on the magnetic plates.

*The protective cover protects against mechanical damage, magnetism and environmental influences. If you remove the protective cover, the magnetic plate may be damaged.*

### 6.1 Conditions

During transport and storage avoid damage to the coil parts, magnetic plates and individual components. Observe the specifications in the following chapters and comply with the following conditions:

- Climate category: 3K3 according to EN 60721
- Temperature: -25 °C to +70 °C, maximum fluctuation 20 K/hour
- Humidity: relative humidity 5% to 95%, no condensation
- Use of suitable means of transport
- Transport and storage only in horizontal and vertical position
- Use of the vendor's original packaging

The table shows the maximum stacking height at which you may store and transport the coil parts on a pallet in the original packaging:

Motor type	Stacking height [pieces]
AL802x	6
AL804x	5
AL806x	1

## 6.2 Transport

### ⚠ WARNING

#### **Do not move under suspended loads**

Use suitable means of transport. Secure coil parts and magnetic plates against falling.

*Falling coil parts and magnetic plates can lead to serious or fatal accidents.*

### NOTICE

#### **Do not touch connection points and plug contacts**

Ensure a protected working environment. Avoid contact with ESD sensitive components without ESD protective clothing.

*Electrostatic discharge can damage the circuitry in the coils and electrical components such as thermal contacts.*



#### **Legal regulations for the lifting of loads**

When transporting individual coil parts or magnetic plates without lifting gear, comply with the legal regulations for lifting loads for employees.

### 6.2.1 Linear servomotors

The following options are available for transporting a single coil part:

#### **Up to series AL804x**

- without aids, by hand in compliance with the legal requirements for the lifting of loads, or

#### **From series AL806x**

From series AL806x, we recommend hoists for lifting and transporting the coil parts. A coil part of the AL806x series can be transported horizontally or vertically:

- By means of a suitable hook or eyebolt in the thread on the top of the coil part, with transport belt and sufficiently dimensioned lifting gear

We recommend that the coil part is always lifted horizontally. Only lift and transport in a vertical position if absolutely necessary.

Please refer to sections "AL806x horizontal and AL806x vertical", [Page 67]

## 6.2.1.1 AL806x horizontal

Before screwing the eyebolts into the coil part, please observe the following instructions:

- Use thread on the upper side
- Use eyebolts according to DIN 580
- Note thread depths and screw depths for the threads in the coil part  
See Chapter "Mechanical installation, section Assembly, coil part", [Page 89]
- Use washers if the set screws of the eyebolts are too long
- Use transport belts of the same length for each eyebolt so that the coil part does not tilt

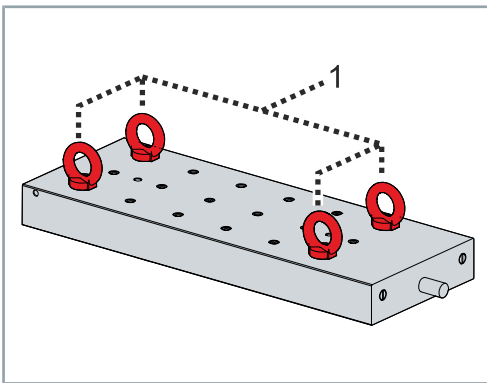

- ▶ Screw eyebolts [1] into the outer adjacent threads on the outer sides. Make sure to always choose the largest possible distance from each other

## 6.2.1.2 AL806x vertical

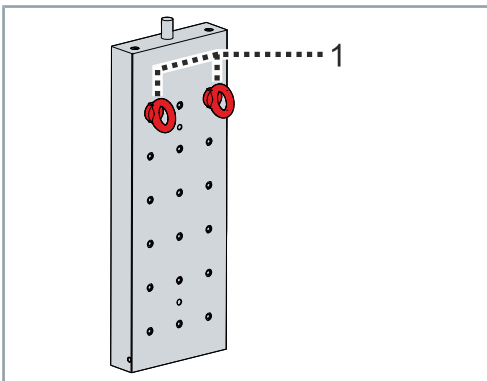

**If it is absolutely necessary to lift the coil part vertically:**

- ▶ Screw eyebolts [1] into the outer adjacent threads on the outer edge

## 6.2.2 Magnetic plates

The following options are available for transporting a single magnetic plate:

- Without aids, by hand in compliance with the legal requirements for the lifting of loads

## 6.3 Long-term storage

### NOTICE

#### Observe storage conditions

Coil parts and magnetic plates can be stored for an unlimited period. Ensure that low air humidity is maintained when storing coil parts and magnetic plates.

*Failure to observe this may result in changes in the properties of the cables or the sealing compound.*

### NOTICE

#### Perform recurring inspections

Check the coil part for proper condition every six months.

*Damage to the coil part or maintenance work not carried out on the machine / system will affect the service life of the installed components and parts.*

### NOTICE

#### Prevent the formation of condensation

Keep the ambient temperature constant. Avoid solar radiation and high air humidity.

*Condensation water can lead to damage during subsequent operation, calcification or rust formation.*

The coil parts can be stored for shorter or longer periods. We always recommend storing components in the original packaging. Observe the conditions specified in chapter: "Transport and storage", [Page 65].

Ensure the storage space is vibration-free.

## 7 Technical description

### 7.1 Magnetic track length

This chapter contains information on determining the length of the magnetic track. The necessary travel range is determined by the application specifications.

The required magnetic path length corresponds to the travel range including the length of the coil part used.

During the planning phase it is necessary to determine the number of magnetic plates required.

Two options are available for determining the number of magnetic plates required:

- conventional calculation and
- effective calculation.

Both approaches calculate a minimum requirement. In practice, the magnetic tracks are longer, since the space for limit switches and reserves is included in the calculation. In addition, whole magnetic plates are always used.

#### 7.1.1 Conventional calculation

In a conventional calculation, the length of the coil part is added to the travel path of the application and then divided by the length of the magnetic plate.



**Example for conventional calculation:**

Travel path = 490 mm

Length of coil part AL8041 = 93 mm

Length of magnetic plate AL8542 = 288 mm

**Required number of magnetic plates:**

$(490 \text{ mm} + 93 \text{ mm})/288 = 2.02$  magnetic plates < 3 magnetic plates are required

## 7.1.2 Effective calculation

In an effective calculation, the travel path of the application is added to the length of the effective section of the coil part and then divided by the length of the magnetic plate.

### Effective section

The effective section contains are the coils of the coil part. In this part the force is generated that drives the motor forward. The remaining installation space includes the wiring.

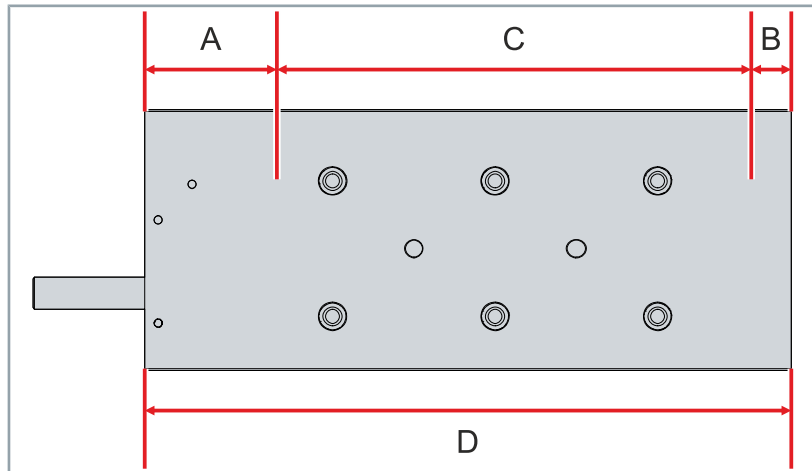

Position	Meaning
A	Passive part of the cable side
B	Passive part of the end side
C	Effective section
D	Housing length = sum of A + B + C



### Example of effective calculation:

The values used here can be found in the following tables.

Travel path = 490 mm

Effective range of the coil part AL8041 = 76 mm

Length of magnetic plate AL8542 = 288 mm

### Required number of magnetic plates:

$(490 \text{ mm} + 76 \text{ mm}) / 288 = 1.97$  magnetic plates < 2 magnetic plates are required

### AL802x

Name	AL80			
	21	22	24	26
Passive part of the cable side A [mm]	15.5	17.5		
Passive part of the end side B [mm]	1.5			
Effective range C [mm]	76	124	220	316
Housing length D [mm]	93	143	239	335

### AL804x

Name	AL80						
	41	42	43	44	45	46	48
Passive part of the cable side A [mm]	15.5	17.5					22.5
Passive part of the end side B [mm]	1.5						
Effective range C [mm]	76	124	172	220	268	316	412

Name	AL80						
	41	42	43	44	45	46	48
Housing length D [mm]	93	143	191	239	287	335	436

AL806x

### Convection-cooled coil part

Name	AL80		
	64-0	65-0	6A-0
Passive part of the cable side A [mm]	17.5	17.5	22.5
Passive part of the end side B [mm]	1.5		
Effective range C [mm]	220	268	508
Housing length D [mm]	239	287	532

### Water-cooled coil part

Name	AL80			
	66-1	6A-1	6B-1	6F-1
Passive part of the cable side A [mm]	31.5			
Passive part of the end side B [mm]	2.5			
Effective range C [mm]	316	508	556	748
Housing length D [mm]	350	542	590	782

## 7.2 Air gap

The air gap is created between the bottom of the coil part and the top of the magnetic plate. The air gap for Beckhoff linear motors is 0.5 mm while maintaining the overall mounting height.

### 7.2.1 Overall mounting height

You can increase the overall mounting height and the associated air gap in case of tolerance deviations. Tolerance deviations can result from:

- deviations in parallelism or
- deviations in the evenness of the mounting surface



#### Be aware of performance losses with increased air gap

Increasing the overall mounting height or the air gap may have performance implications. These follow a non-linear function. Please refer to the diagram in Chapter: "Dependencies", [Page 73].

#### Avoid reducing the air gap

Reducing the air gap increases the attractive forces between the coil part and the magnetic track. This requires larger guides and a stiffer design of the machine or system.

The following table and figure provide information about the overall mounting heights of the individual series:

Series	Mounting height "X" [mm]
AL802x	40 ± 0.1
AL804x	40 ± 0.1
AL806x-0xxx	45 ± 0.1
AL806x-1xxx	47 ± 0.1

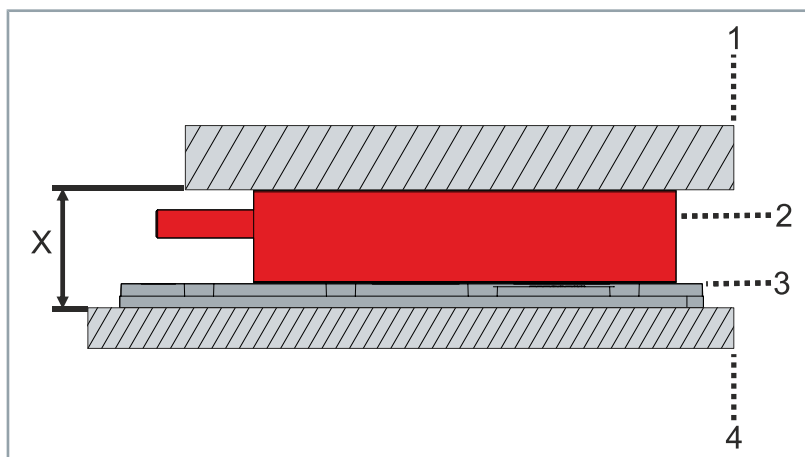

Position	Description
1	Machine slide
2	Coil part
3	Magnetic plate
4	Machine bed



## 7.2.2 Dependencies

The following diagram shows the continuous force in relation to the attractive force as a function of the air gap:

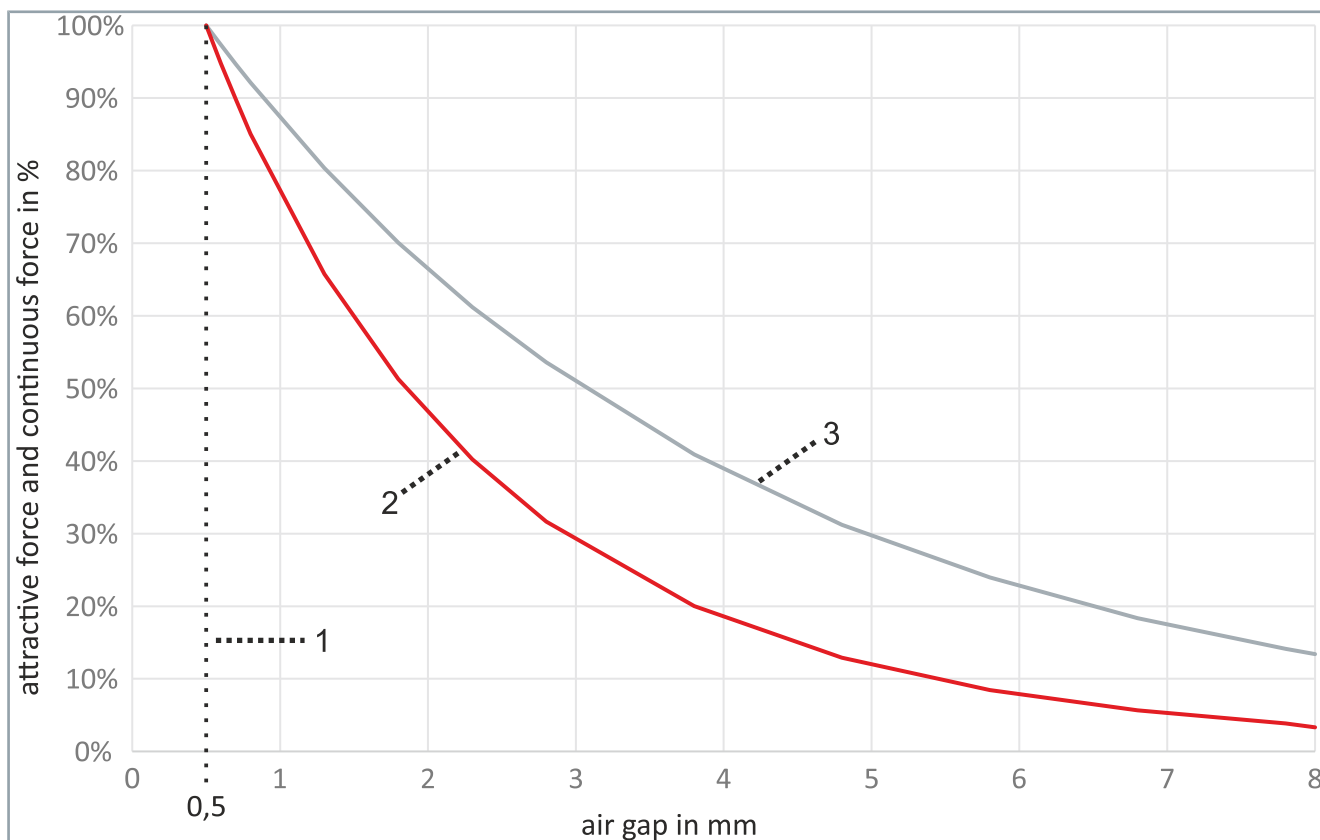

Position	Definition
Setpoint 1	Ideal air gap
Curve 2	Attractive force $F_a$
Curve 3	Continuous force $F_c$

## 7.3 Protection equipment

A temperature sensor LPTC-600 is installed in all coil parts of the AL8000 series. The LPTC-600 is integrated into the monitoring system of the servo drives for motors with preassembled plugs. Configure the servo drive according to the motor temperature warning at 80 °C and the switch-off temperature at 100 °C.

### 7.3.1 LPTC-600 sensor

The following table shows the resistance values of the temperature sensor:

Temperature [°C]	LPTC-600 Resistance [Ω]			Temperature error [K]
	minimum	Nominal value	maximum	
-40	340	359	379	± 6.48
-30	370	391	411	± 6.36
-20	403	424	446	± 6.26
-10	437	460	483	± 6.16
0	474	498	522	± 6.07
10	514	538	563	± 5.98
20	555	581	607	± 5.89
25	577	603	629	± 5.84
30	599	626	652	± 5.79
40	645	672	700	± 5.69
50	694	722	750	± 5.59
60	744	773	801	± 5.47
70	797	826	855	± 5.34
80	852	882	912	± 5.21
90	910	940	970	± 5.06
100	970	1000	1030	± 4.90
110	1029	1062	1096	± 5.31
120	1089	1127	1164	± 5.73
130	1152	1194	1235	± 6.17
140	1216	1262	1309	± 6.63
150	1282	1334	1385	± 7.10
160	1350	1407	1463	± 7.59
170	1420	1482	1544	± 8.10
180	1492	1560	1628	± 8.62

## 8 Coupling

### NOTICE

#### Ensure synchronization of coupled coil parts

Ensure that the coupled coil parts move synchronously.

*Rigidly coupled coil parts can cause non-synchronous movements which can lead to tension and damage to the mechanical system and the coil part.*

### NOTICE

#### Only use parallel connection for coupling coil parts

Coil parts should only be coupled in a parallel connection. Series connection is not permitted.

*Failure to observe this may cause a cable fire and result in damage to the coil part and connected components.*

You have the possibility to couple individual coil parts with the same installation width and the same force constants. The total force is determined by adding the forces of the coupled coil parts. The motors are connected in parallel to the servo drive, which leads to higher sum currents. In coupled operation, maintain special distances between coil parts and the dependent wiring.

## 8.1 Structure

You have the possibility to couple the linear motors in two different ways. These are described in the following chapter.

### 8.1.1 Gantry

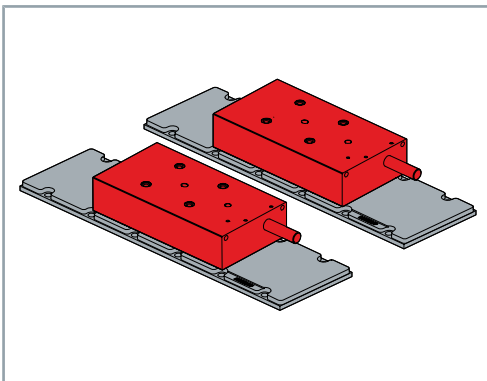

In a gantry structure, two parallel magnetic tracks each have a coil part. The coil parts are rigidly coupled and electrically connected in parallel. The movements are synchronized. Synchronization must be maintained at the best possible level even in the event of a drive error.

All coil parts in the gantry structure must respond almost instantaneously to any drive faults.

The existing communication time from the faulty drive to the NC or CNC and from there to all other coil parts is overridden by the electrically parallel switching.

## 8.1.2 Common magnetic track

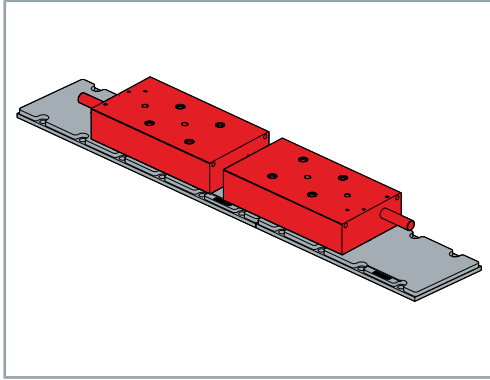

With this type of coupling, the coil parts are arranged one after the other on a common magnetic track. This type of coupling tends to be used for applications with long strokes, since a second magnetic track with associated costs is avoided.

By coupling two coil parts of the next smaller series, the force required for the application can be achieved and thus the width of the magnetic track can be reduced.

## 8.2 Arrangement of coil parts

The coil parts must be arranged such that the distances shown in this chapter are adhered to. They thus guarantee the generation of a symmetrical rotary field and adhere to the minimum bending radius of the cables.

### 8.2.1 Cable arrangement

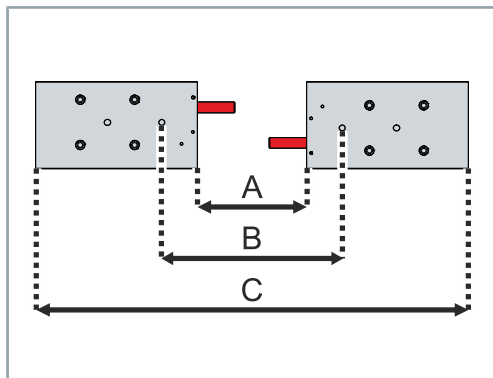

This illustration shows an example of two coil parts with cables facing each other.

The dimensions A - B - C are provided in the following tables.

- A = minimum distance
- B = center-to-center distance between locating pin holes
- C = total length

AL802x				
Motor 1	Motor 2	A	B	C
		[mm]		
AL8021-0Eyz	AL8021-0Eyz	53	76	239
AL8022-0Eyz	AL8022-0Eyz	49	112	335
AL8024-0Gyz	AL8024-0Gyz	49	208	527
AL8026-0Gyz	AL8026-0Gyz	49	208	719

AL804x				
Motor 1	Motor 2	A	B	C
		[mm]		
AL8041-0Eyz	AL8041-0Eyz	53	64	239
AL8042-0Eyz	AL8042-0Eyz	49	112	335
AL8043-0Eyz	AL8043-0Eyz	49	208	431
AL8043-0Gyz	AL8043-0Gyz	49	208	431
AL8044-0Eyz	AL8044-0Eyz	49	208	527
AL8044-0Hyz	AL8044-0Hyz	49	208	527
AL8045-0Gyz	AL8045-0Gyz	49	208	527
AL8045-0Kyz	AL8045-0Kyz	49	208	527
AL8046-0Gyz	AL8046-0Gyz	49	208	527
AL8046-0Kyz	AL8046-0Kyz	49	208	527
AL8048-0Hyz	AL8048-0Hyz	49	208	527
AL8048-0Kyz	AL8048-0Kyz	49	208	527

AL806x-0xxx				
Motor 1	Motor 2	A	B	C
		[mm]		
AL8064-0Fyz	AL8064-0Fyz	51	208	529
AL8064-0Kyz	AL8064-0Kyz	51	208	529
AL8065-0Hyz	AL8065-0Hyz	51	208	625
AL8065-0Kyz	AL8065-0Kyz	51	208	625
AL806A-0Kyz	AL806A-0Kyz	57	224	1121

# Coupling

AL806x-0xxx				
Motor 1	Motor 2	A	B	C
		[mm]		
AL806A-0Qyz	AL806A-0Qyz	57	224	1121

AL806x-1xxx				
Motor 1	Motor 2	A	B	C
		[mm]		
AL8066-1Jyz	AL8066-1Jyz	53	240	753
AL8066-1Nyz	AL8066-1Nyz	53	240	753
AL806A-1Kyz	AL806A-1Kyz	53	240	1137
AL806A-1Ryz	AL806A-1Ryz	53	240	1137
AL806B-1Lyz	AL806B-1Lyz	53	240	1233
AL806F-1Nyz	AL806F-1Nyz	53	240	1617
AL806F-1Tyz	AL806F-1Tyz	53	240	1617

## 8.2.2 Cables in the same direction

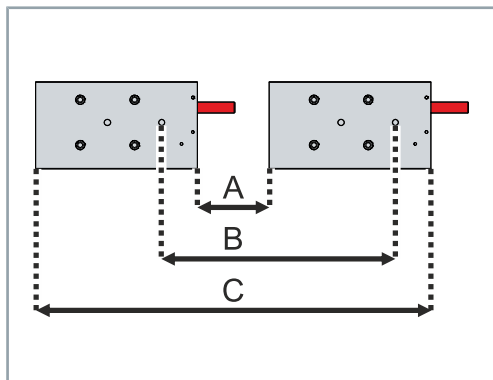

This illustration shows an example of an arrangement of two coil parts with cables in the same direction.

The dimensions A - B - C are provided in the following tables.

- A = minimum distance
- B = center-to-center distance between locating pin holes
- C = total length

AL802x				
Motor 1	Motor 2	A	B	C
		[mm]		
AL8021-0Eyz	AL8021-0Eyz	51	144	237
AL8022-0Eyz	AL8022-0Eyz	49	192	335
AL8024-0Gyz	AL8024-0Gyz	49	288	527
AL8026-0Gyz	AL8026-0Gyz	49	384	719

AL804x				
Motor 1	Motor 2	A	B	C
		[mm]		
AL8041-0Eyz	AL8041-0Eyz	51	144	237
AL8042-0Eyz	AL8042-0Eyz	49	192	335
AL8043-0Eyz	AL8043-0Eyz	49	240	431
AL8043-0Gyz	AL8043-0Gyz	49	240	431
AL8044-0Eyz	AL8044-0Eyz	49	288	527
AL8044-0Hyz	AL8044-0Hyz	49	288	527
AL8045-0Gyz	AL8045-0Gyz	49	288	527
AL8045-0Kyz	AL8045-0Kyz	49	288	527
AL8046-0Gyz	AL8046-0Gyz	49	288	527
AL8046-0Kyz	AL8046-0Kyz	49	288	527
AL8048-0Hyz	AL8048-0Hyz	49	288	527
AL8048-0Kyz	AL8048-0Kyz	49	288	527

AL806x-0xxx				
Motor 1	Motor 2	A	B	C
		[mm]		
AL8064-0Fyz	AL8064-0Fyz	49	288	527
AL8064-0Kyz	AL8064-0Kyz	49	288	527
AL8065-0Hyz	AL8065-0Hyz	49	336	623
AL8065-0Kyz	AL8065-0Kyz	49	336	623
AL806A-0Kyz	AL806A-0Kyz	60	592	1124
AL806A-0Qyz	AL806A-0Qyz	60	592	1124

# Coupling

AL806x-1xxx				
Motor 1	Motor 2	A	B	C
		[mm]		
AL8066-1Jyz	AL8066-1Jyz	50	400	750
AL8066-1Nyz	AL8066-1Nyz	50	400	750
AL806A-1Kyz	AL806A-1Kyz	50	592	1134
AL806A-1Ryz	AL806A-1Ryz	50	592	1134
AL806B-1Lyz	AL806B-1Lyz	50	640	1230
AL806F-1Nyz	AL806F-1Nyz	50	832	1614
AL806F-1Tyz	AL806F-1Tyz	50	832	1614



## 8.2.3 Cables opposite

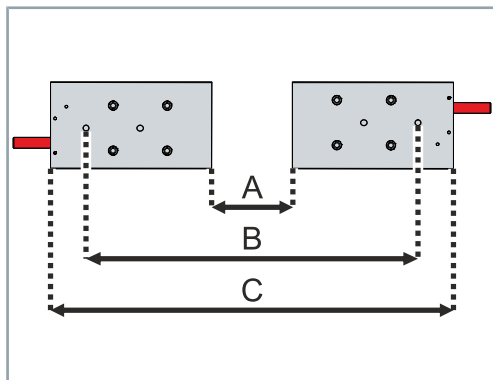

This illustration shows an example of an arrangement of two coil parts with cables laid in opposite directions.

The dimensions A - B - C are provided in the following tables.

- A = minimum distance
- B = center-to-center distance between locating pin holes
- C = total length

AL802x				
Motor 1	Motor 2	A	B	C
		[mm]		
AL8021-0Eyz	AL8021-0Eyz	1	164	187
AL8022-0Eyz	AL8022-0Eyz	1	224	287
AL8024-0Gyz	AL8024-0Gyz	1	320	479
AL8026-0Gyz	AL8026-0Gyz	1	512	671

AL804x				
Motor 1	Motor 2	A	B	C
		[mm]		
AL8041-0Eyz	AL8041-0Eyz	1	176	187
AL8042-0Eyz	AL8042-0Eyz	1	224	287
AL8043-0Eyz	AL8043-0Eyz	1	224	383
AL8043-0Gyz	AL8043-0Gyz	1	224	383
AL8044-0Eyz	AL8044-0Eyz	1	320	479
AL8044-0Hyz	AL8044-0Hyz	1	320	479
AL8045-0Gyz	AL8045-0Gyz	1	320	479
AL8045-0Kyz	AL8045-0Kyz	1	320	479
AL8046-0Gyz	AL8046-0Gyz	1	320	479
AL8046-0Kyz	AL8046-0Kyz	1	320	479
AL8048-0Hyz	AL8048-0Hyz	1	320	479
AL8048-0Kyz	AL8048-0Kyz	1	320	479

AL806x-0xxx				
Motor 1	Motor 2	A	B	C
		[mm]		
AL8064-0Fyz	AL8064-0Fyz	15	336	493
AL8064-0Kyz	AL8064-0Kyz	15	336	493
AL8065-0Hyz	AL8065-0Hyz	15	432	589
AL8065-0Kyz	AL8065-0Kyz	15	432	589
AL806A-0Kyz	AL806A-0Kyz	15	912	1079
AL806A-0Qyz	AL806A-0Qyz	15	912	1079

# Coupling

AL806x-1xxx				
Motor 1	Motor 2	A	B	C
		[mm]		
AL8066-1Jyz	AL8066-1Jyz	15	528	715
AL8066-1Nyz	AL8066-1Nyz	15	528	715
AL806A-1Kyz	AL806A-1Kyz	15	912	1099
AL806A-1Ryz	AL806A-1Ryz	15	912	1099
AL806B-1Lyz	AL806B-1Lyz	15	1008	1195
AL806F-1Nyz	AL806F-1Nyz	15	1392	1579
AL806F-1Tyz	AL806F-1Tyz	15	1392	1579

## 8.3 Electrical connection

Wire the coupled coil parts according to the phase offset. The windings of the coil parts always have the same winding distance to one another, which is dependent on the series. In the case of the AL8xxx series, the winding distance is 16 mm.

If the coil parts are coupled to one another, there must also be a multiple of this winding distance between the windings of the connected coil parts. The phase repetition is 48 mm and is made up of three times the winding distance.

In the following illustrations you can get information about the distance between the phase lines.

The following information is included in the figures:

- A = minimum distance
- m = distance from the stop on the cable side to the first phase center
- n = distance from the last phase center to the end side
- $PD_{M1M2}$  = distance between the phase centers of the first phases at the stop on the cable side
- All figures in millimeters



### Example 1: AL8042 and AL8042 with cables in opposite directions

This alignment of the coil parts enables the minimum distance between the coil parts.

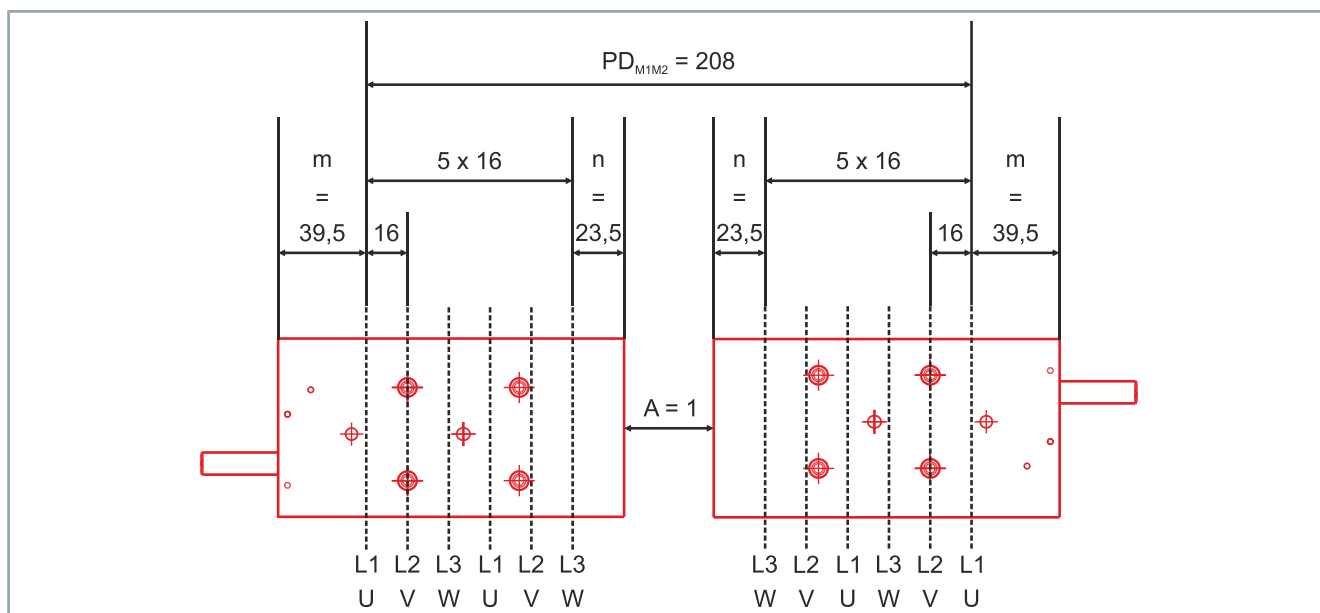



## Example 2: AL8042 and AL8042 with cables in the same direction

With this alignment, observe the minimum bending radius of the motor cables.

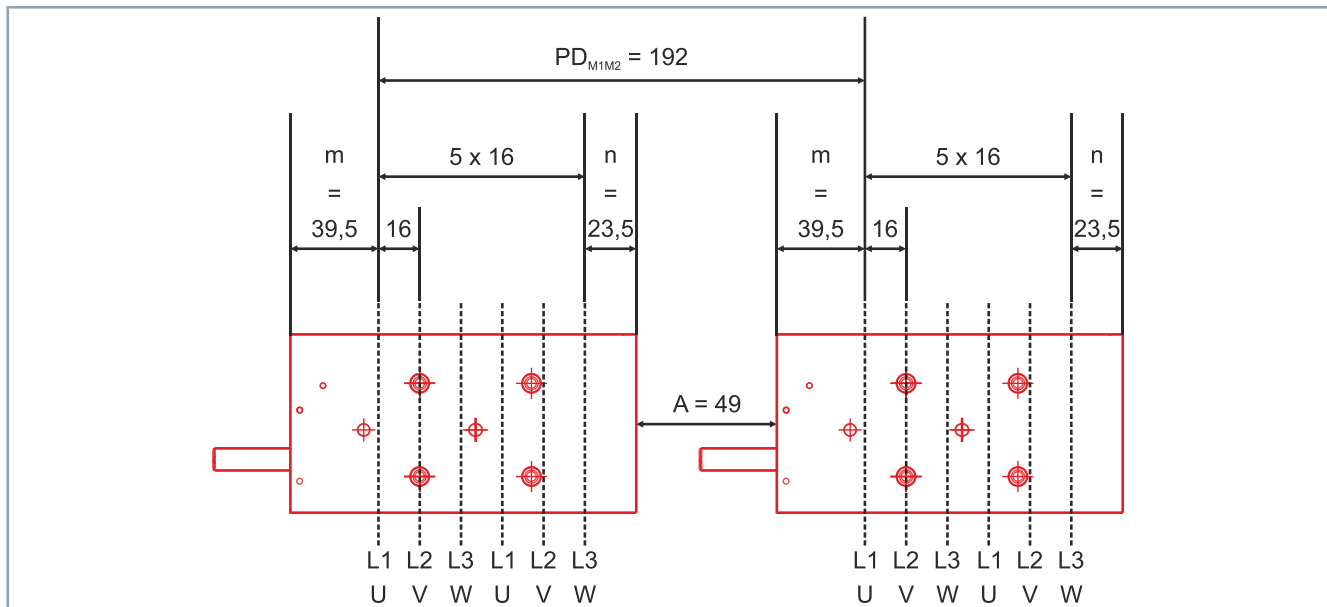

### 8.3.1 Offset calculation

Carry out the wiring according to the arrangement of the coil parts. You have to calculate the offset for the wiring. The offset indicates the number of coils by which the rotary field is shifted in the second coil part.

Calculate the offset using the following equation:  $(PD_{M1M2}/16) \text{ MOD } 3$

Information on  $PD_{M1M2}$  can be found in the chapter: "Electrical connection", [Page 83]

Information on the wiring can be found in the chapter: "Power supply", [Page 86]



## Example 1: AL8042 and AL8042 with cables in opposite directions

$PD_{M1M2} = 208$  mm

Offset =  $(208/16) \text{ MOD } 3 = 1$

## Example 2: AL8042 and AL8042 with cables in opposite directions

$PD_{M1M2} = 192$  mm

Offset =  $(192/16) \text{ MOD } 3 = 0$

## 8.3.2 Phase lines

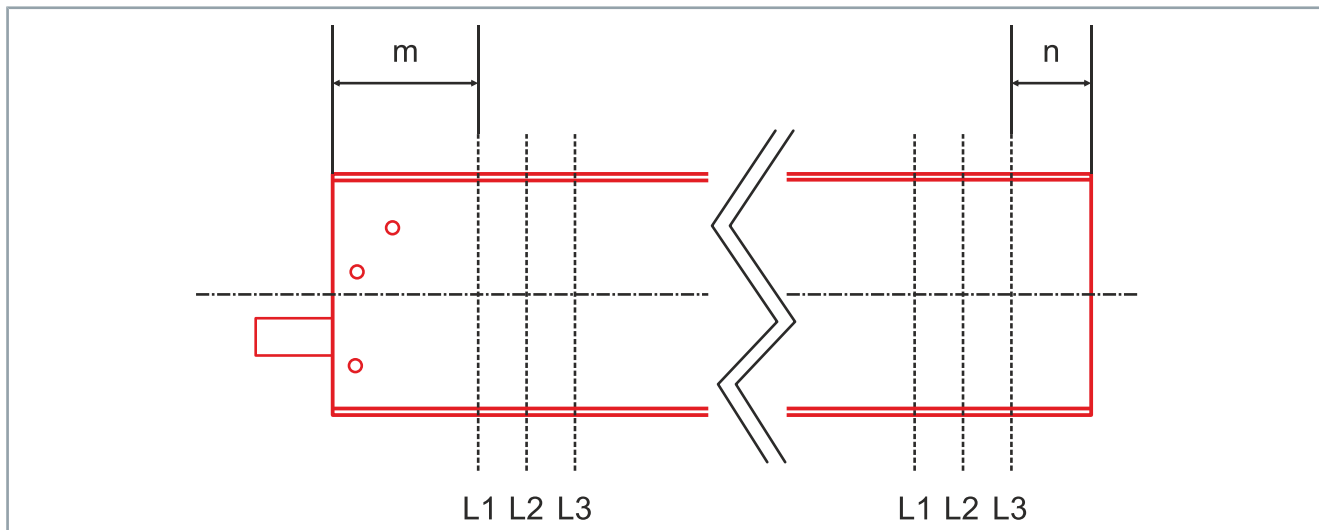

Motor	m	n
	[mm]	
AL8021	37.5	23.5
AL8022	39.5	23.5
AL8024	39.5	23.5
AL8026	39.5	23.5
AL8041	37.5	23.5
AL8042	39.5	23.5
AL8043	39.5	23.5
AL8044	39.5	23.5
AL8045	39.5	23.5
AL8046	39.5	23.5
AL8048	44.5	23.5
AL8064-0xxx	38.5	24.5
AL8065-0xxx	38.5	24.5
AL806A-0xxx	43.5	24.5
AL8066-1xxx	53.5	24.5
AL806A-1xxx	53.5	24.5
AL806B-1xxx	53.5	24.5
AL806F-1xxx	53.5	24.5

## 8.3.3 Power supply

With the calculated offset and using the following tables, you can carry out the wiring of the coupled coil parts.

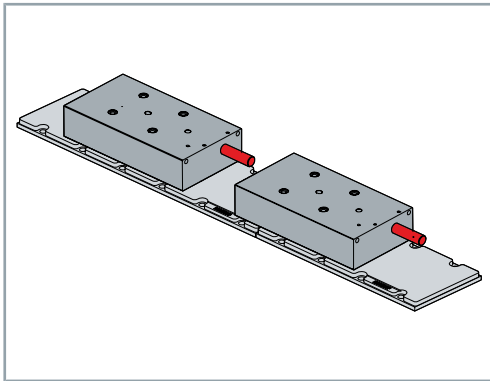

Cables in same direction			
Offset	L1	L2	L3
0	L1	L2	L3
1	L3	L1	L2
2	L2	L3	L1

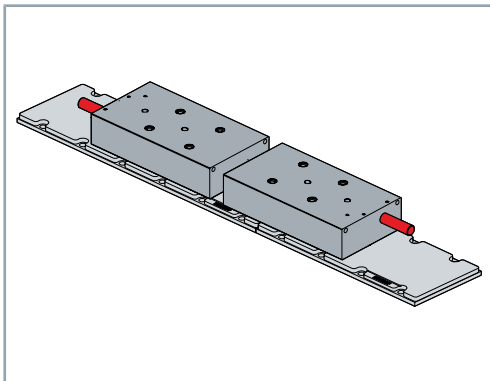

Cables in opposite directions			
Offset	L1	L2	L3
0	L2	L1	L3
1	L3	L2	L1
2	L1	L3	L2

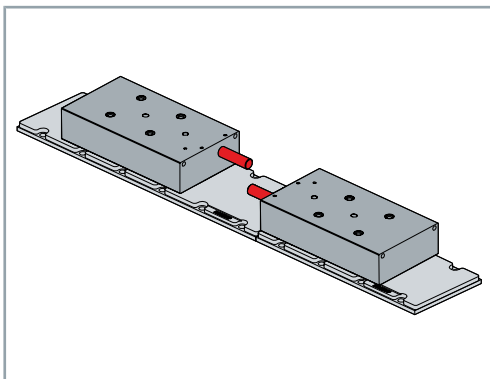

Cables to each other			
Offset	L1	L2	L3
0	L2	L1	L3
1	L1	L3	L2
2	L3	L2	L1

## 8.3.4 Temperature sensor

By electrically connecting the coil parts in parallel to a servo drive, only one temperature sensor can be connected. Always connect the temperature sensor of the coil part with the worst cooling connection and the highest temperature development. This will trigger the switch-off procedure in the servo drive in case of a critical temperature rise in the poorly cooled coil part.

## 9 Mechanical installation

All work should be carried out with great care and without time pressure.

### 9.1 Requirements

When designing and dimensioning the machine or system, observe the basic requirements for the machine bed and the assembly of the coil part and magnetic plates.

#### 9.1.1 Evenness

The specified mounting height is based on the specified evenness. The following figure shows the values for evenness and parallelism for the coil unit and the magnetic plate.

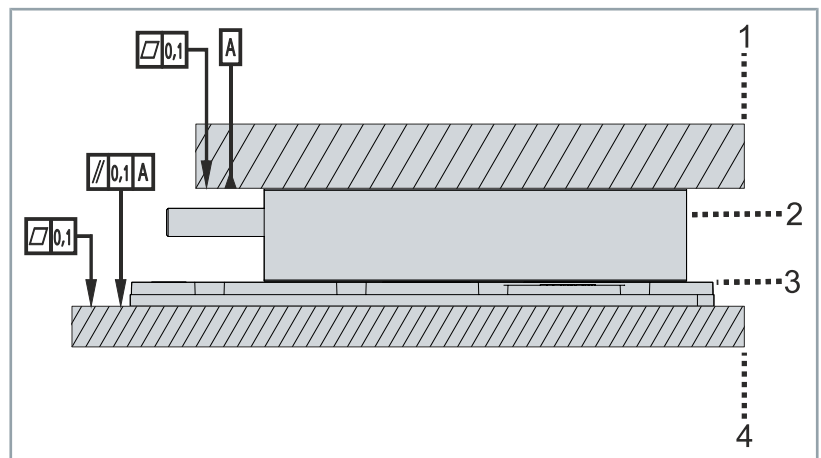

Position	Description
1	Machine slide
2	Coil part
3	Magnetic plate
4	Machine bed

Please refer to Chapter "Air gap, section Overall mounting height", [Page 72]

## 9.2 Assembly

### **⚠ WARNING**

#### **Warning of strong magnetic attractive forces**

Avoid standing within the travel range of the coil part even when the machine or system is switched off. The permanent magnets of the magnetic plates and coils of the coil part attract each other. The high attractive forces cannot be controlled by hand.  
*Non-observance can result in serious or fatal injuries due to crushing.*

### **NOTICE**

#### **Only use compatible magnetic plates**

Only use original magnetic plates from the AL8xxx product series. Other magnetic plates are incompatible in the pole sequence.  
*Failure to observe this may result in serious injury and damage to the machine due to uncontrolled movements of the linear motor.*

### **NOTICE**

#### **Use only the drill holes shown**

Use only the drill holes shown for the assembly or for other activities described in these operating instructions. Drill holes not shown may be present, for example, for production purposes.  
*Non-compliance will result in damage to the motor.*

During assembly, make sure that the magnetic track can be divided into two sections. The sections must be at least as large as the machine carriage.



#### **Clean the mounting surfaces**

Make sure that all mounting surfaces are oil-free, grease-free and unpainted. Remove any dirt or dust.

#### **Observe the mounting sequence**

First mount the coil part on the machine carriage. Then mount the machine carriage including the coil part on the guides. Finally, mount the magnetic plates.

#### **Observe the screw requirements**

Observe the minimum and maximum screw depths of the screws. Information on the screw depths can be found in the individual sections during mounting. Please observe the permissible torques and standards.



## 9.2.1 Coil part



### Loss of force due to asymmetry

Place the coil part symmetrically to the magnetic plate for the AL806x-1xxx series. For the AL8x2x, AL804x and AL806x-0xxx series, the coil part is positioned with an offset to the magnetic plate. *Failure to observe this may result in loss of force at the linear motor and loss of performance in the machine or system.*



### Dimensional drawings for alignment

Please read the following chapters:

- "Technical data, paragraph AL802x, "alignment AL802x", [Page 35]"
- "Technical data, paragraph AL804x, "alignment AL804x", [Page 47]"
- "Technical data, paragraph AL806x-0, "alignment AL806x-0", [Page 54]"
- "Technical data, paragraph AL806x-1, "alignment AL806x-1", [Page 60]"

## Mounting

- ▶ Clean the mounting surface on the coil part and on the machine carriage

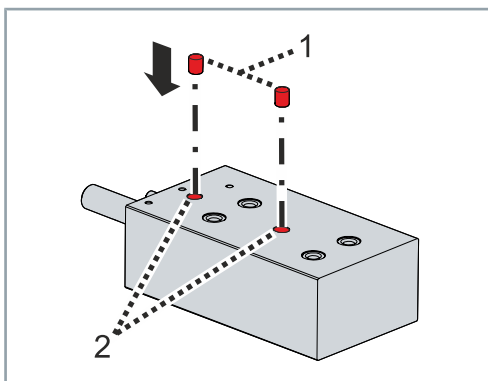

- ▶ Insert locating pins [1] into the holes of the coil part [2]:

Locating pins	
Tolerance zone	M6
Maximum screw depth	4 mm

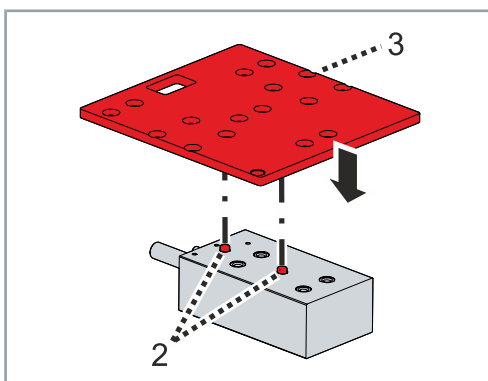

- ▶ Place the machine carriage [3] with the holes on the locating pins [2] of the coil part
- ▶ Align the coil part, making sure that all the holes are aligned

# Mechanical installation

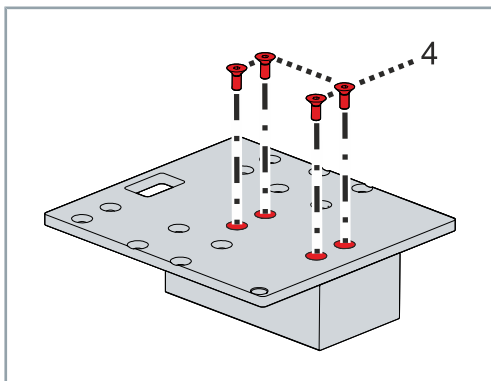

- ▶ Insert the screws [4] and tighten them crosswise from inside to outside

## Observe tightening torques:

Screw quality = strength class 8.8	
Screw	M5 x 0.8
Recommended screw depth	5 mm
Maximum screw depth	6 mm
Tightening torque	6 Nm

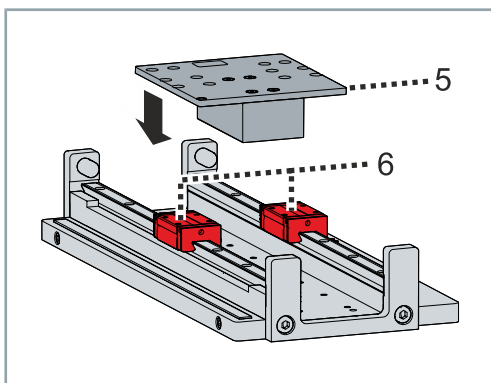

- ▶ Place the assembled coil part including the machine carriage [5] on the guide carriage [6]

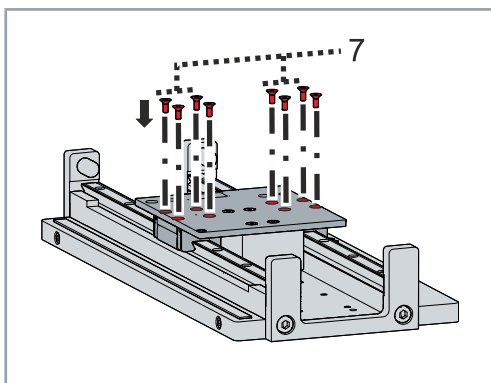

- ▶ Insert and tighten the screws [7]

## 9.2.2 Magnetic plates

**⚠ WARNING****Do not remove the protective cover**

The cover weakens the magnetic field and protects electrical components from magnetic influences.

*Severe crushing injuries may result if the strong magnetic field of the permanent magnets in the magnetic plate unexpectedly attracts the components magnetically during assembly.*

**NOTICE****Observe the alignment**

Align the magnetic plates identically. The Beckhoff logo must always be on the same side.

*If this is not observed, the adjacent magnetic plates repel each other. As a result, the coil part cannot move without restriction. The system is not operational.*

**NOTICE****Observe minimum clearance**

Keep the required minimum distance when mounting additional magnetic plates. This is 48 mm between hole centers. During mounting, maintain a distance of at least 10 cm between the magnetic plate to be mounted and the mechanically protected coil part.

*Failure to observe this can lead to complications during installation.*

**Minimum distance (example)**

The diagram shows the minimum distance between two magnetic plates.

- Distance between hole centers: 48 mm

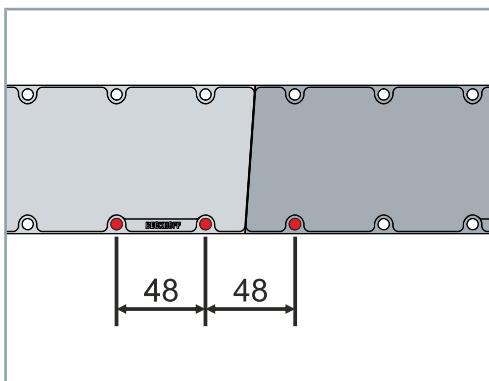

# Mechanical installation

## Mounting

- ▶ Clean the mounting surface on the machine bed and the magnetic plate

- ▶ Push the machine slide [1] to one end of the machine bed [2]

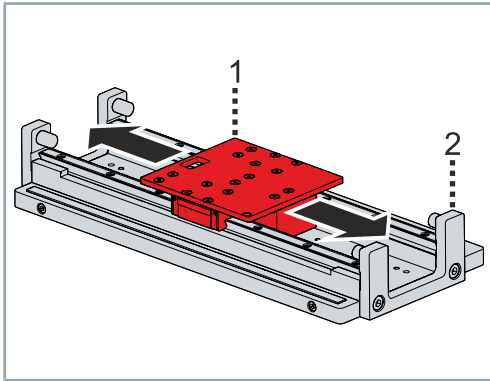

### ⚠ WARNING

#### Secure the machine slide sufficiently

Secure the machine slide mechanically against uncontrolled movements. Do not reach under the machine slide or hold the machine slide by hand.

*If the strong magnetic field of the permanent magnets in the magnetic plate unexpectedly attracts the components magnetically during assembly, it is not possible to hold the machine slide by hand. Severe injuries to limbs can be the result.*

- ▶ Mechanically secure the machine slide against the attractive forces and uncontrolled movements of the magnetic plate

- ▶ Insert locating pins [3] into the machine bed

- ▶ Pay attention to the insertion depth of the locating pins [3]

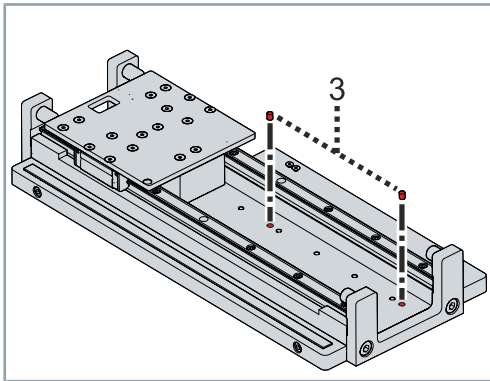

Locating pins	AL852x	AL854x	AL856x
Tolerance zone	M6		
Maximum immersion in the magnetic plate	3.2 mm	5.5 mm	

- ▶ Check the alignment of the magnetic plate. Make sure that the Beckhoff logos are on the same side.

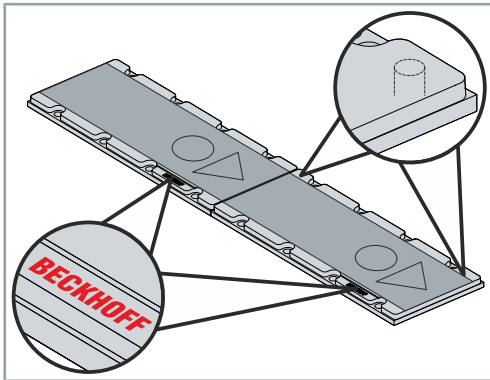

- ▶ Place the magnetic plate [4] on the locating pins [3]

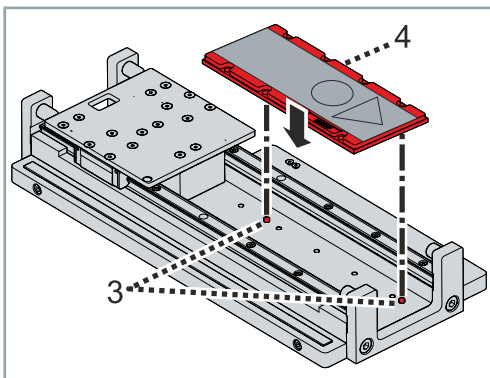

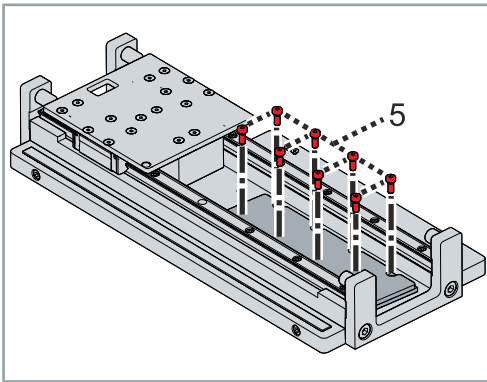

- ▶ Insert screws [5] into the magnetic plate on the machine bed
- ▶ Tighten the screws crosswise and from inside to outside

### Observe tightening torque:

Quality of the screws = strength class 8.8	
Bolt	M5
Tightening torque [Nm]	6

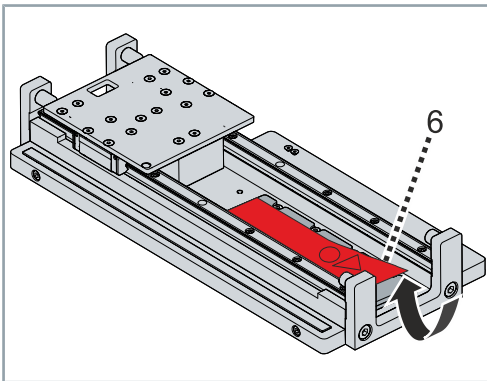

- ▶ Remove the protective cover [6] on the mounted magnetic plates onto which the machine slide is to be pushed. Do not dispose of the protective cover and keep it for subsequent transport of the machine or system.

### Other magnetic plates

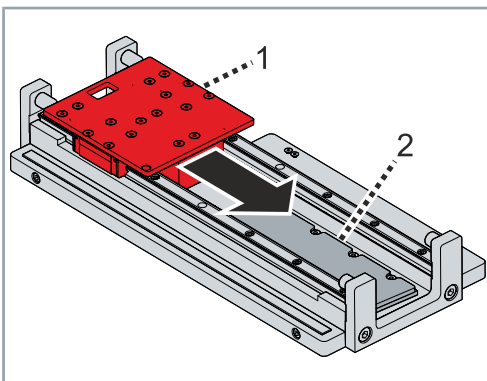

- ▶ Slide the machine slide [1] onto the mounted magnetic plates [2]
- ▶ Secure the machine slide mechanically against uncontrolled movements
- ▶ Mount the other magnetic plates in the same way

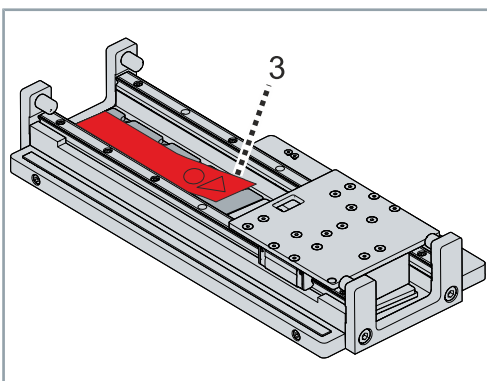

### Once all components have been fitted and you start up the machine or system:

- ▶ Remove all protective covers [3] on all magnetic plates

## 9.2.3 Water cooling [+]

### NOTICE

#### Install cooling circuits as closed systems

Implement the cooling circuits as closed systems. The maximum permissible pressure is 10 bar.

*Non-compliance may result in pressure losses at the connection points, and open cooling circuits can lead to soiling and microbial contamination. This can result in damage to the machine or system and loss of performance.*

### NOTICE

#### Cooling coil parts with additional cooling circuit

If necessary, install an additional cooling circuit to cool the coil parts.

*Grease, dirt residues or long-term deposits can hinder the flow of coolant and block the cooling circuits. Pressure loss and loss of performance can be the result.*

### NOTICE

#### Only use suitable coolant

Coolants are not included in the scope of delivery and cannot be procured from BECKHOFF. Operate the motor only with an approved and suitable coolant. Consult your coolant manufacturer in order to obtain a suitable coolant.

*Non-compliance will result in damage to the motor. The use of unsuitable coolants will lead to the forfeiture of the warranty and other claims for damages.*



#### Use of coolant with corrosion protection

Corrosion protection forms a protection layer on the cooling surface and prevents deposits and corrosion. If you wish to exchange a motor in the cooling system at some time, we recommend replacing the coolant with corrosion protection. An old coolant cannot form an adequate protective layer in future.

### 9.2.3.1 Cooling circuit design

The table below contains important technical specifications for the installation of the cooling circuit. Adhere to the specifications for flow rate and pressure drop in order to achieve the continuous force. We recommend monitoring the flow rates and the pressure. If an error should occur, you can counteract and avoid the overheating of the motor at an early stage.

AL804x			
Motor	Continuous power loss $P_c$	Flow rate Q	Pressure drop $\Delta p$
	[W]	[l/min]	[bar]
AL8041	63	0.1	0.00

<b>AL804x</b>			
<b>Motor</b>	<b>Continuous power loss <math>P_c</math></b>	<b>Flow rate Q</b>	<b>Pressure drop <math>\Delta p</math></b>
	<b>[W]</b>	<b>[l/min]</b>	<b>[bar]</b>
AL8042	126	0.2	0.01
AL8043	169	0.2	0.03
AL8044	238	0.3	0.05
AL8045	298	0.4	0.08
AL8046	358	0.5	0.10
AL8048	458	0.7	0.16
All values valid for a temperature increase $\Delta T$ of 10 K			

<b>AL806x-1</b>			
<b>Motor</b>	<b>Continuous power loss <math>P_c</math></b>	<b>Flow rate Q</b>	<b>Pressure drop <math>\Delta p</math></b>
	<b>[W]</b>	<b>[l/min]</b>	<b>[bar]</b>
AL8066-1xyz	661	1.0	0.1
AL806A-1xyz	1206	1.8	0.3
AL806B-1xyz	1140	1.95	0.4
AL806F-1xyz	1710	2.5	0.7
All values valid for a temperature increase $\Delta T$ of 10 K			

## 9.2.3.2 Direction of flow

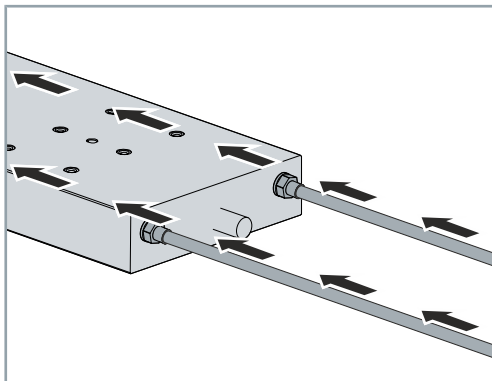

- AL804x: Water flow in the same direction

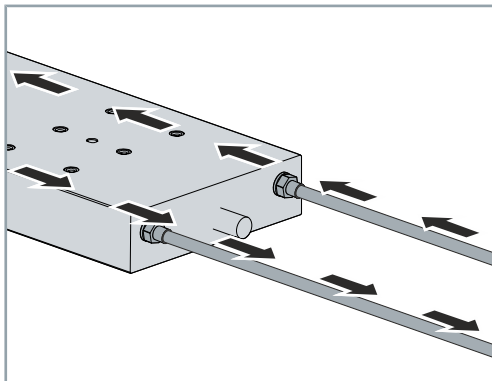

- AL806x-1: Water flow as cooling circuit



## 9.2.3.3 Mounting

### NOTICE

#### Sealing the motor correctly

Seal the cooling connections using suitable screw connections. Do not use cone sealing couplings or sealants in the thread, such as liquid sealants or Teflon tape. Observe the permissible thread depth and the maximum tightening torque in aluminum.

*Non-compliance can lead to damage to the motor and to the complete system.*

For the connection of the cooling hoses we recommend push-in fittings with male thread:

Coil part	Male thread
AL804x	M5
AL806x-1xxx	G 1/8 "

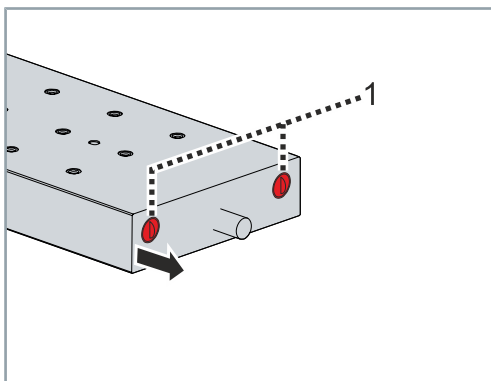

- ▶ Remove the plug [1] at the front on the coil part

#### AL804x:

- ▶ Remove the plug on the opposite side of the coil part

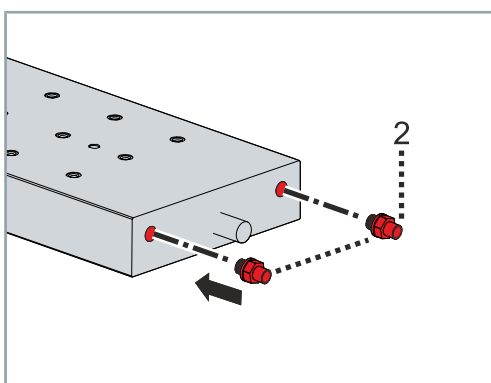

- ▶ Screw the threaded push-in fittings [2] into the holes provided

#### AL804x:

- ▶ Screw in the threaded push-in fittings on the opposite side of the coil part

## NOTICE

### Use opaque cooling hoses

Use opaque cooling hoses to connect the water cooling and add suitable chemical additives.

*Failure to observe this may result in algae formation inside the cooling hoses. Algae formation can shorten the life of the cooling hoses and negatively affect the performance of the linear motor.*

For connecting the push-in fittings, we recommend the following cooling hose sizes:

Coil part	Hose	
	Inner diameter	Outside diameter
	[mm]	
AL804x	4	6
AL806x-1xxx	6	8

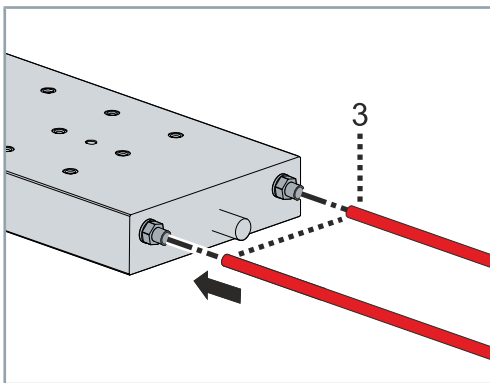

- ▶ Insert the cooling hoses [3] into the threaded push-in fittings

### AL804x:

- ▶ Connect cooling hoses at the opposite side of the coil part

## 9.3 Verification

After assembly, check the installed components for smooth running and adequate "air gap", [Page 72].

### 9.3.1 Smooth operation



#### **Smooth running of the machine slide**

The machine slide should move smoothly along the entire magnetic track. A permanent air gap must exist between the coil part and the magnetic track.

If you cannot move the coil part smoothly, check the assembly of your application. Observe all specifications from Chapter "Mechanical installation", [Page 87]

To check the smooth running of the machine slide, carry out the following steps:

- ▶ Remove all tools from the machine or system
- ▶ Clean the magnetic track
- ▶ Move the machine slide carefully by hand and guide it along the entire length of the magnetic track

## 10 Electrical installation

### 10.1 Connection technology

Beckhoff supplies prefabricated power and feedback cables. For the selection of the necessary cables, refer to the Beckhoff documentation for the connecting cables. In the documentation you will find a complete overview of the available cables and information on the technical data.



#### **For interference-free data transmission, please note:**

- Maximum number of mating cycles for the connectors: 500 cycles

*If the mating cycles are exceeded, contact problems may result.*

#### 10.1.1 Cables

#### **NOTICE**

##### **Do not lay cable in drag chains**

The cable of the AL8000 is firmly encapsulated with the linear motor. It is part of the wear-free product. Do not lay the cable in a drag chain.

*A limited service life or damage to the linear motor is the result. Non-compliance will void the warranty and other claims for damages.*

#### **NOTICE**

##### **Avoid soiling and damage**

When connecting the coupling and the plug, make sure that the poles and the inside of the component are not soiled or damaged.

*Failure to do so may adversely affect the function of the connections.*



#### **Hint for trouble-free application and assembly:**

- Wiring in accordance with applicable regulations and standards
- Use of pre-assembled and shielded Beckhoff cables

Beckhoff offers pre-assembled cables for faster and flawless installation of the motors. These cables are tested with regard to the material used, shielding and connection type. The use of other cables can cause unexpected malfunctions and result in exclusion of warranty.

## 10.2 Connector assignment

Beckhoff offers various power connectors and feedback connectors. All plugs are IP65 rated.

The following tables show the connector assignment:

### 10.2.1 iTec® plug

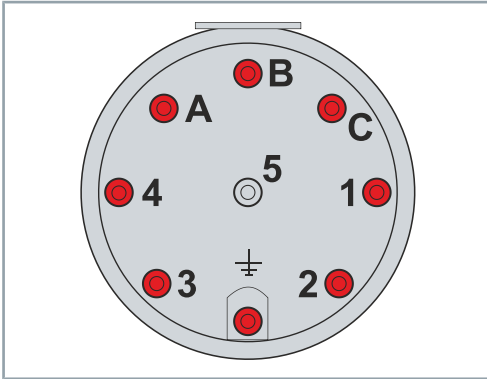

Pin assignment cable diameter 1.0 mm <sup>2</sup>			
Contact	Function	Color	Core identification
A	U	Black	1
B	W	Black	3
C	V	Black	2
1	---	---	---
2	---	---	---
3	Temperature+/ U <sub>s</sub>	White	---
4	Temperature-/ GND	Blue	---
5	Shield	Shield	---
PE	PE	Green/yellow	---

### 10.2.2 M23 Speedtec® plug

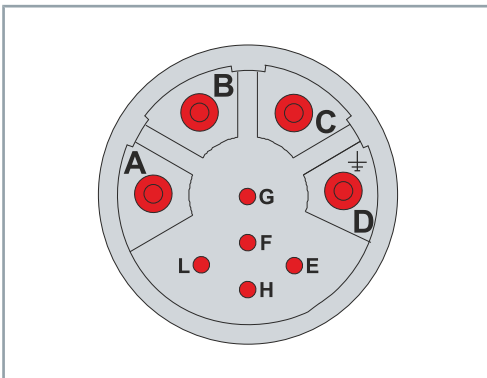

Pin assignment cable diameter 1.5 mm <sup>2</sup> and 2.5 mm <sup>2</sup>			
Contact	Function	Color	Core identification
A	U	Black	1
B	V	Black	2
C	W	Black	3
PE	PE	Green/yellow	---
E	Temperature-/ GND	Blue	---
F	Shield	Shield	---
G	---	---	---
H	Temperature+/ U <sub>s</sub>	White	---
L	---	---	---

## 10.2.3 M40 Speedtec® plug

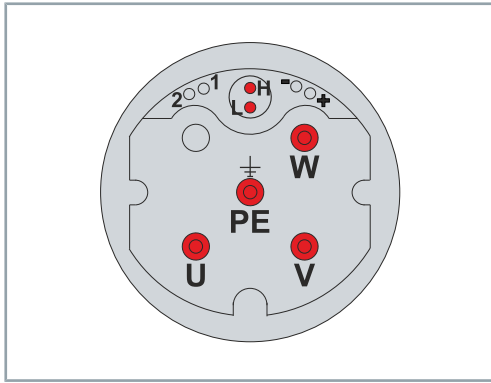

Pin assignment cable diameter 4 mm <sup>2</sup>			
Contact	Function	Color	Core identification
U	U	Black	1
V	V	Black	2
W	W	Black	3
PE	PE	Green/yellow	---
N	n.c.	---	---
+	---	---	---
-	---	---	---
1	---	---	---
2	---	---	---
H	Temperature+/ U <sub>s</sub>	White	---
L	Temperature-/ GND	Blue	---

## 11 Commissioning



### **Exemplary commissioning**

The procedure for commissioning is described as an example. A different method may be appropriate or necessary, depending on the application of the components.

### 11.1 Before commissioning

Pay attention to the following points before commissioning:

- In the case of multi-axis systems, commission each drive unit separately
- Read the operating instructions for the servo drive
- Check drive for damage
- Check mounting and alignment
- Tighten screw connections correctly
- Installing mechanical, thermal and electrical protective devices
- Check the wiring, connection and proper grounding of the motor and servo drive

### 11.2 During commissioning

Pay attention to the following points during commissioning:

- Check function and adjustment of attachments
- Observe information for environment and operation
- Check protective measures against moving and live parts

#### **Configuration**

Beckhoff recommends using Beckhoff servo drives and motors and configuration with Beckhoff TwinCAT 3 Drive Manager 2 | TE5950.

Carry out the instructions in the operating manual for servo drives:

- Build Project and Choose Target System
- Implement devices by scanning or manually
- Create axis configuration
- Set scaling factor and speeds
- Check status and activate control system

## 11.3 Prerequisites during operation

Pay attention to the following points during operation:

- Pay attention to unusual noise developments
- Always check drive surfaces and cables for dirt, leaks, moisture or dust
- Check temperature development
- Check for lubricant leakage
- Check function of safety devices

**For motors with water cooling:**

- Check hoses and cables for soiling
- Check that the motor and connections are firmly seated
- Observe tightening torques

## 11.4 After operation

### **WARNING**

#### **Place the machine or plant in a safe state**

Make sure that the motor comes to a complete stop.

*Uncontrolled movements of the coil units can lead to serious injuries or damage to the system or machine.*



## 12 Maintenance and cleaning

### ⚠ WARNING

#### Ensure safe condition for cleaning work

Basically, electronic devices are not fail-safe. The condition is always safe when the unit is switched off and not energized. For cleaning work, bring the connected motors and the machine into a safe state.

*Carrying cleaning work during operation can lead to serious or fatal injuries.*

### NOTICE

#### Do not submerge or spray the motor

Only wipe the motor with a cleaner and a cloth.

*Cleaning by immersion may result in surface and motor damage and leakage problems as a result of impermissible solutions.*

Linear motors are essentially maintenance-free. Dirt, dust or chips along the guide rails can negatively affect the function of the linear motor. Extreme soiling can lead to failure.

## 12.1 Cleaning agents

Clean the components carefully with a damp cloth or a brush.

Use grease-dissolving and non-aggressive cleaning agents such as isopropanol for cleaning. You will also receive information about non-approved cleaning agents.

### 12.1.1 Not applicable

Cleaning agents	Chemical formula
Aniline hydrochloride	$C_6H_5NH_2HCl$
Bromine	$Br_2$
Sodium hypochlorite; bleaching solution	$NaClO$
Mercury (II) chloride	$HgCl_2$
Hydrochloric acid	$HCl$

## 13 Decommissioning

Disassembly may only be carried out by qualified and trained personnel.

Read the chapter Documentation notes.

When disposing of electronic waste, make sure that you dispose of it in accordance with the regulations applicable in your country. Read and follow the instructions for proper disposal.

### 13.1 Disassembly

#### **⚠ WARNING**

##### **Risk of injury during disassembly**

Permanent magnets are installed in the AL85xx magnetic plates. Carefully remove the magnetic plates. Make sure that the magnetic plates and ferromagnetic objects are not magnetically attracted and that your hands are not between these components. *If you don't take care during the disassembly, opposite magnetic plates may attract each other without warning and injure your hands.*

##### **Removing the magnetic plates from the machine:**

- Push the machine slide to one side and mechanically secure it against uncontrolled movements
- Attach protective covers to the magnetic plates. The protective cover is included with the magnetic plates.
- Unscrew and remove the bolts
- Remove the magnetic plate
- Remove the locating pin
- Push the machine slide to the other side and mechanically secure it against uncontrolled movements
- Remove the other magnetic plates in the same way

##### **Removing the coil part from the machine:**

- If present: Remove the water cooling
- Disconnect the electrical connector
- Remove the machine slide from guide rails
- Unscrew and remove the bolts
- Separate the coil part from the machine slide
- Remove the locating pins

## 13.2 Disposal

Depending on your application and the products used, ensure the professional disposal of the respective components:

### Cast iron and metal

Dispose of cast and metal parts as scrap metal for recycling.

### Cardboard, wood and foam polystyrene

Dispose of packaging materials made of cardboard, wood or foam polystyrene in accordance with the regulations.

### Plastics and hard plastics

You can recycle parts made of plastic and hard plastic via the recycling depot or re-use them depending on the component designations and markings.

### Oils and lubricants

Dispose of oils and lubricants in separate containers. Hand over the containers at the used oil collection station.

### Batteries and rechargeable batteries

Batteries and rechargeable batteries may also be marked with the crossed-out trash can symbol. You must separate these components from the waste and are legally obliged to return used batteries and rechargeable batteries within the EU. Observe the relevant provisions outside the area of validity of the EU Directive 2006/66/EC.



### Electronic components

Products marked with a crossed-out waste bin must not be disposed of with general waste. Electronic components and device are considered as waste electrical and electronic equipment for disposal. Observe the national regulations for the disposal of old electrical and electronic equipment.

### 13.2.1 Returning to the vendor

In accordance with the WEEE-2012/19/EU directives, you can return used devices and accessories for professional disposal. The transport costs are borne by the sender.

Send the used devices with the note "For disposal" to:

Beckhoff Automation GmbH & Co. KG  
 "Service" Building  
 Stahlstrasse 31  
 D-33415 Verl

In addition, you have the option to contact a local certified specialist company for the disposal of used electrical and electronic appliances. Dispose of the old components in accordance with the regulations applicable in your country.

## 14 Guidelines and Standards

Test procedures and certifications vary by product. Beckhoff linear servomotors of the AL8000 series are certified and tested according to the following directives and standards.

### 14.1 Standards

**EN 60034-1:2010+Corr.:2010**

*"Rotating electrical machines – Rating and performance"*

**RoHS: EN 50581:2012**

*"Technical documentation for the assessment of electrical and electronic products with respect to the restriction of hazardous substances"*

### 14.2 Guidelines

**2014/35/EU**

Low Voltage Directive



**2014/30/EU**

EMC Directive

**2011/65/EU**

RoHS Directive

### 14.3 Test centers

	The motors do not fall within the scope of the Machinery Directive. However, Beckhoff products are designed and evaluated in full compliance with all relevant regulations for personal safety and use in a machine or system.
	The motors meet all the requirements of the Eurasian Economic Union. These include Russian Federation, Belarus, Armenia, Kazakhstan and Kyrgyzstan. The EAC logo can be found on the name plate.
	The motors comply with UL requirements and are certified as cURus components for the US and Canadian markets in accordance with the standards applicable in the USA and Canada. The cURus logo can be found on the name plate.

## 14.4 EU conformity



### **Provision**

Beckhoff Automation GmbH & Co KG will be pleased to provide you with EU declarations of conformity and manufacturer's declarations for all products on request.

Please send your request to: [info@beckhoff.com](mailto:info@beckhoff.com)

## 14.5 CCC conformity



### **Export to Chinese Economic Area**

Beckhoff linear motors of the AL8000 series are not subject to the China Compulsory Certificate; CCC. The products are exempt from this certification and can be exported to the Chinese economic area.



More Information:  
[www.beckhoff.com/al8000](http://www.beckhoff.com/al8000)

Beckhoff Automation GmbH & Co. KG  
Hülshorstweg 20  
33415 Verl  
Germany  
Phone: +49 5246 9630  
[info@beckhoff.com](mailto:info@beckhoff.com)  
[www.beckhoff.com](http://www.beckhoff.com)

